

DAIHATSU
TYPE CB
ENGINE

[CB-23, CB-61 & CB-80]

DAIHATSU MOTOR CO., LTD.
NO.9173-GE



WORKSHOP MANUAL

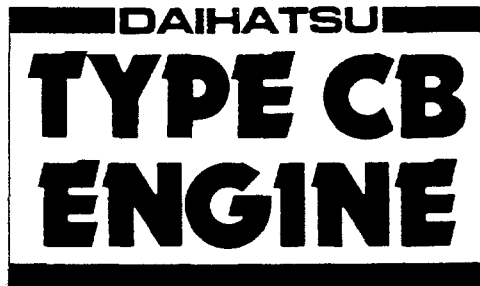

[CB-23, CB-61 & CB-80]

FOREWORD

This workshop manual contains essential information regarding the construction, operation, adjustment procedure and servicing method of the Type CB-23, CB-61 and CB-80 engines which are mounted on the DAIHATSU CHARADE.

The contents and specifications in this manual may be partly revised without advance notice and without incurring any obligation to us.

Published in June, 1987

DAIHATSU MOTOR CO., LTD.

WM-0000

SECTION INDEX

NAME	SECTION
GENERAL INFORMATION	1
THE ENGINE PROPER	2
ENGINE TUNE-UP	3
IN-VEHICLE SERVICE	4
ENGINE MECHANICALS	5
FUEL SYSTEM	6
LUBRICATION SYSTEM	7
COOLING SYSTEM	8
TURBOCHARGER SYSTEM	9
ENGINE ELECTRICAL SYSTEM	10
INTAKE SYSTEM	11
EXHAUST EMISSION CONTROL SYSTEM	12
APPENDIX	13



DAIHATSU
TYPE CB
ENGINE

[CB-23, CB-61 & CB-80]

SECTION 1

GENERAL INFORMATION

HOW TO USE THIS WORKSHOP MANUAL	1-2
INSTRUCTIONS ON SERVICE OPERATIONS	1-3
JACKING POINTS AND SUPPORTING POINTS	
OF SAFETY STANDS	1-5
SUPPORTING POINTS OF TWO-POST LIFT	1-5
LOCATION OF ENGINE TYPE AND	
ENGINE NUMBER	1-6
ENGINE TYPE EMBOSSED POSITION	1-6
ENGINE NUMBER STAMPED POSITION	1-6
ABBREVIATION CODES	1-7
MAIN SPECIFICATIONS	1-9

WM-01001

GENERAL INFORMATION

HOW TO USE THIS WORKSHOP MANUAL

[Articles To Be Prepared]

As regards general tools (those tools which are normally provided in a service shop), jacks and other standard equipment, they are omitted in this workshop manual.

As for those Special Service Tools (SSTs) which are necessary for the service operations, they are posted collectively in the tables under SECTION 11 APPENDIX. Hence, please prepare them prior to the service operation.

In respect to instruments, lubricants and so forth, be sure to use those designated by Daihatsu.

WM-C1002

[Composition]

1. The component diagram is provided in the beginning of each section. Refer to this component diagram whenever you want to assure the shape or the part name of each part during the installation operation or the removal operation.
2. In principle, each section is arranged in the following order. However, it should be noted that the composition for the in-vehicle operation differs from this order.

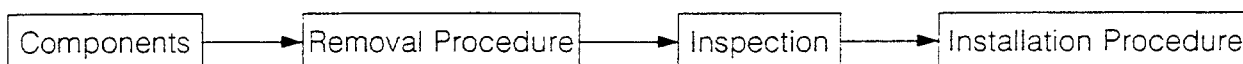

However, instances where the removal or the installation is comparatively easy or no SST or the like is required, the arrangement is made as follows:



3. With regard to the tightening torque specifications, they are indicated in the Engine Components and Tightening Torque under SECTION 3-10. In addition, they are shown in the tables under SECTION 11 SERVICE SPECIFICATIONS.

However, as for those items where no specific tightening torque is mentioned, perform the operation referring to the Tightening Torque for Main Components under SECTION 00.

WM-01003

[Numerals]

As regards those numerals which are posted under "Inspection" and under sections other than SECTION 11 SERVICE SPECIFICATIONS, those numerals from the specified values to the allowable limits are posted. As for those numerals which are posted under SECTION 11 SERVICE SPECIFICATIONS, those numerals concerning the specified values and allowable limits are indicated separately.

WM-01004

[NOTE]

1. "NOTES" posted in the main text clearly show those items which need particular attention or prohibited items which must be avoided during the service operation.
2. Prior to the operation, make certain to take any necessary precautionary measures so as to prevent personal injury during the removal/installation of parts.

WM-01005

INSTRUCTIONS ON SERVICE OPERATIONS

1. Make sure that only the specified bolts and nuts are used. Also, where specified, be sure to employ a torque wrench to tighten bolts or nuts to specifications.
2. When tightening or slackening bolts, be sure to progressively tighten or slacken them over several stages, slightly at a time. This caution must be observed to prevent the tightened parts from being distorted or damaged.
3. Use only genuine parts for every replacement operation.
4. For increased working efficiency and improved accuracy, utilize SSTs (Special Service Tools) effectively.
5. When both front and rear sections of the vehicle or only the rear section thereof is jacked up, make certain to place chocks at the wheels correctly in order to assure safe operations.
6. When the vehicle is jacked up, make sure to support the vehicle with safety stands positioned at the specified jacking points.
7. Before any repair work is made on the electrical system or the engine is removed or installed, first be sure to disconnect the negative (–) terminal of the battery.
8. Disassembly
 - (1) When complicated parts are disassembled, put stamped marks or mate marks on suitable non-functional sections of the parts in order that the said parts may be easily assembled in the correct original positions.
 - (2) Replacements of the cylinder block or crankshaft, etc. should be carried out after the engine assembly has been removed from the vehicle.
9. Checks to be performed during disassembly
Each time a part is removed, check conditions under which the part has been assembled. Also, check to see if the part exhibits any evidence of distortion, breakage, wear or scores, etc.
10. Arrangement of disassembled parts
Put disassembled parts in a good order. Moreover, divide disassembled parts into two groups: those parts to be replaced and those parts which can be reused.
11. Washing disassembled parts
As for those parts which can be reused, thoroughly clean or wash them. (except grease sealed bearing)
12. Inspection
Those parts which are to be reused must be carefully inspected or measured, as required.
13. Those operations specified under "Inspection" are performed, in principle, in combination with the checks and repairs. It is, therefore, necessary to replace any part which does not conform to the specifications. However, in cases where otherwise specified in the main text, be sure to follow the given instructions.
14. Assembly of parts
Those satisfactory parts only should be assembled in accordance with the prescribed standards (e.g. specified adjustment values, tightening torque and so forth).
Furthermore, seal packing or grease should be applied, as required.
Furthermore, in respect to packings, gaskets, oil seals and similar items, be certain to install new parts.
15. Adjustments and checking of service operations
Service operations must be carried out correctly by means of gauges or testers, if the use of these instruments is required.
16. Never smoke during the service operation. Also, be sure not to allow any fire to be brought near the working bay.
17. Under no circumstances should your hand touch with the front side and back sides, the installation surfaces of each bearing insert. Also, be very careful not to scratch the surfaces. Do not wipe off the bearing surfaces with a cloth. Be certain to blow off them, using compressed air.
Protect your eyes with safety glasses during this cleaning.

GENERAL INFORMATION

18. The warming-up state of the engine means a state in which the temperature of the cooling water reaches at least 75 - 85°C (167 - 185 F) and the temperature of the engine oil reaches at least 65°C (149 F).

These temperatures can be judged by observing a point where the cooling fan motor ceases its rotation.

NOTE:

When the idle speed is checked on Type CB-80 engine, special warming-up procedure is required. Hence, be sure to refer to the section under "Checking Idle Speed."

WM-01006

JACKING POINTS AND SUPPORTING POINTS OF SAFETY STANDS

• **Jacking point**

- Front side Engine mounting center member (Place the jack below the member, exercising care of the exhaust pipe.)
- Rear side Center of rear floor cross member

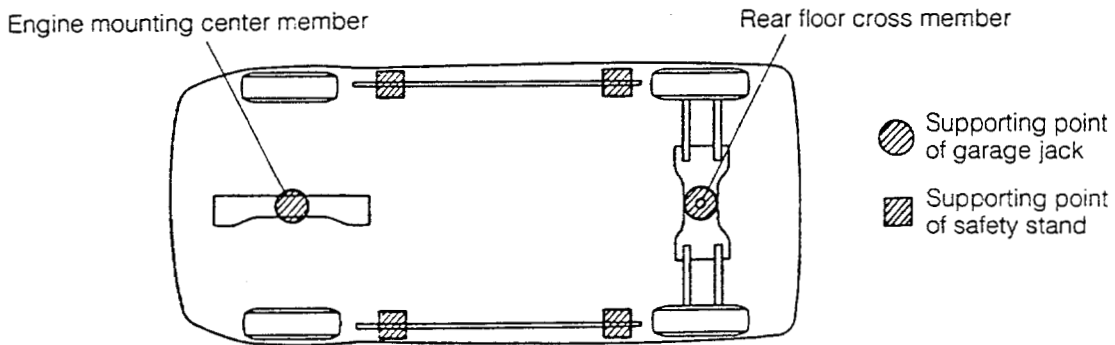

• **Supporting points of safety stands**

Four supporting points are located at the right and left sides. (The supporting points have been strengthened by spot-welding reinforcements. Never support the vehicle at points other than the specified points.)

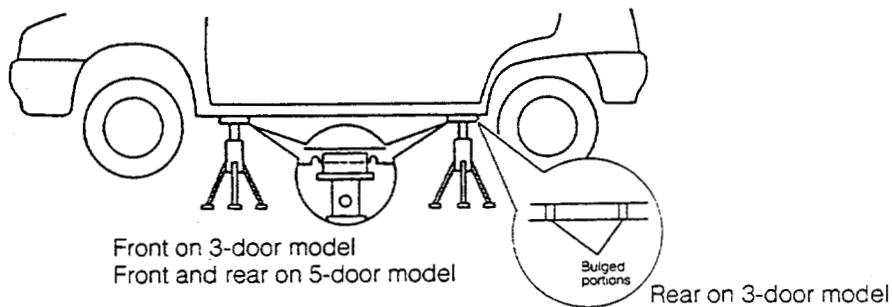

Fig. 1-1

WR-01007

SUPPORTING POINTS OF TWO-POST LIFT

Place the supporting pads of a two-post lift with the supporting points of safety stands, as indicated in the figure above.

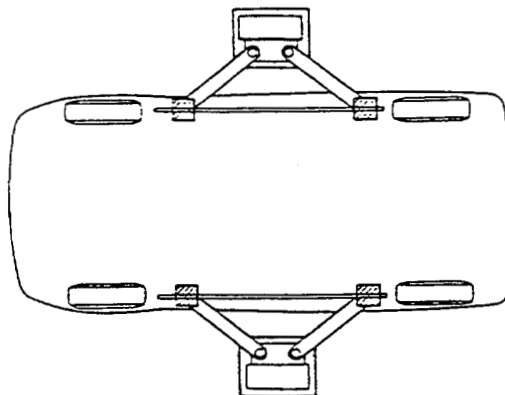

Fig. 1-2

WR-01008

GENERAL INFORMATION

LOCATION OF ENGINE TYPE AND ENGINE NUMBER

ENGINE TYPE EMBOSSED POSITION

The engine type is embossed on the power train side of the cylinder block.

ENGINE NUMBER STAMPED POSITION

1. CB-23 and CB-61

The engine serial number is stamped on the cylinder head at the front end section.

For the Australian specifications, the engine number is stamped also at the side of the embossed engine type.

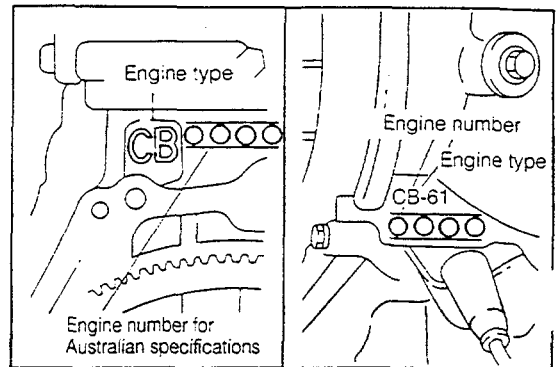

Fig. 1-3

WR-01009

2. CB-80

The engine serial number is stamped on the cylinder head at the rear end section

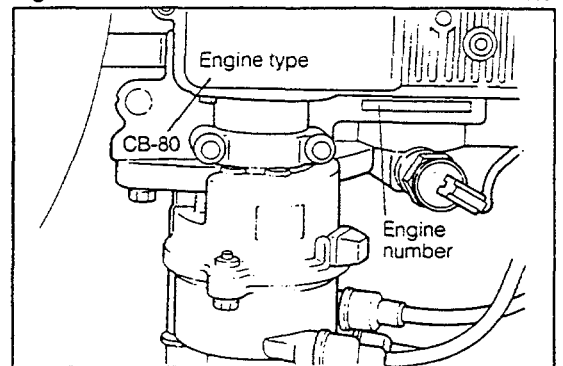

Fig. 1-4

WR-01010

BBREVIATION CODES

The abbreviation codes that appear in this workshop manual stand for the following, respectively.

Abbreviation code	Original word	Meaning
RH	Right Hand	Refers to right side.
LH	Left Hand	Refers to left side.
FR	FRont	Refers to front side.
RR	ReaR	Refers to rear side.
STD	StanDard	When referring to automotive parts, "standard" represents those parts which have been installed originally by the manufacturer and which have standard dimensions.
O/S	Over Size	In instances where fitting becomes too loose due to wear resulting from use for a long period of time or due to frequent removal/installation operations, if fitting part (e.g. piston) is replaced with a part having larger dimensions, the other mating part may be put into use again. "Over sized" parts denote those parts having larger dimensions compared with standard parts.
U/S	Under Size	In the same manner as with the "oversized" parts, if fitting part (e.g. bush and bearing) is replaced with a part having smaller bore dimensions, the other mating part may be put into use again. "Under sized" part denote those parts having smaller dimensions compared with standard parts.
ATDC	After Top Dead Center	Refers to position of piston in cylinder where piston is near but has passed over the top of the stroke.
BTDC	Before Top Dead Center	Refers to position of piston in cylinder where piston is near but has not reached the top of the stroke.
IN	INtake	Refers to intake system.
EX	EXhaust	Refers to Exhaust system.
PR	Pry Rating	Represents strength of tires. The larger the pry rating number, the stronger the tire strength.
SAE	Society of Automotive Engineers	For example, automotive oils are designated as SAE so and so number. These designation numbers have been set forth by the Society of Automotive Engineers in the United States of America (SAE). The larger the SAE number, the higher the oil viscosity. Conversely, the smaller the SAE number, the lower the oil viscosity.
API	American Petroleum Institute	The standards set forth by the American Petroleum institute (abbreviated as API Classification) have been employed to evaluate and classify properties of various oils. Engine oils for gasoline engines are classified as SD, SE and so on, whereas engine oils for diesel engines are classified as CC, CD and so on.
SST	Special Service Tool	Refers to a tool designed for a specific purpose.
T	Torque	Refers to tightening torque.
S/A	Sub-Assembly	Refers to a component comprising more than two single parts which are welded, staked, or studded to each other to form a single component.
Ay/Assy	Assembly	Refers to an assembled component comprising more than two single parts or sub-assembly parts.
W/	With	Denotes that the following part is attached.
L/	Less	Denotes that the following part is not attached.
M/T	Manual Transmission	Refers to manual type transmission.
A/T	Automatic Transmission	Refers to automatic transmission.
T/C	Turbo Charger	
W/G	Waste Gate	Refers to exhaust by-pass.
A/C	Air Cleaner	

GENERAL INFORMATION

List of Abbreviated Component Names of Exhaust Emission Control System

The table below shows abbreviated component names of the exhaust emission control system. The components of the exhaust emission control system are described in this manual in their abbreviated forms.

	Abbreviation	Component name
1	BVSV	Bimetal Vacuum Switching Valve
2	C/O	Choke Opener
3	DP	Dashpot
4	VTV	Vacuum Transmitting Valve
5	VS	Vacuum Switch
6	AD	Advance
7	T.P	Throttle Positioner
8	TVSV	Thermostatic Vacuum Switching Valve
9	EGR	Exhaust Gas Recirculation

WM-01012

AIN SPECIFICATIONS

Item		Engine type	CB-23	CB-61	CB-80	
Type			Petrol, 4-cycle	Petrol, 4-cycle	Petrol, 4-cycle	
Mounting location			Front	Front	Front	
Cylinder No. and arrangement			3-cylinder-in-line, mounted transversely	3-cylinder-in-line, mounted transversely	3-cylinder-in-line, mounted transversely	
Combustion chamber type			Multi-sphere type	Multi-sphere type	Pent roof type	
Valve mechanism			Belt-driven overhead camshaft	Belt-driven overhead camshaft	Belt-driven (DOHC)	
Bore x stroke mm (inch)			76 x 73 (2.99 x 2.87)	76 x 73 (2.99 x 2.87)	76 x 73 (2.99 x 2.87)	
Compression ratio			9.5	8.0	7.8	
Compression pressure kg/cm ² -rpm (psi-rpm)			12.5 - 350 (177.8 - 350)	12.0 - 350 (170.7 - 350)	10.5 - 300 (149.3 - 300)	
Maximum output	SAE net	kw/rpm	General specifications 38/5,600	50/5,500	74/6,500	
	EEC	kw/rpm	Australian specifications 38/5,600	50/5,500	—	
	EEC DIN	kw/rpm	ECE & EEC specifications 38/5,600	50/5,500	74/6,500	
Maximum torque	SAE net	Nm/rpm	General specifications 75.5/3,200	106/3,200	130/3,500	
	EEC	Nm/rpm	Australian specifications 75.5/3,200	106/3,200	—	
	EEC DIN	Nm/rpm	ECE & EEC specifications 75.5/3,200	106/3,500	130/3,500	
Engine dimensions [Length x width x height] mm (inch)			566 x 530 x 636 (22.28 x 20.87 x 25.04)	563 x 520 x 632 (22.17 x 20.47 x 24.88)	576 x 573 x 624 (22.68 x 22.56 x 24.57)	
Service engine weight kg (lb)			92 (202.9)	96 (212)	105 (233.7)	
Number of piston rings	Compression ring		2	2	2	
	Oil ring		1	1	1	
Valve timing	Intake	Open	19°BTDC	11°BTDC	23°BTDC	
		Close	51°ABDC	49°ABDC	51°ABDC	
	Exhaust	Open	51°BBDC	49°BBDC	49°BBDC	
		Close	19°ATDC	11°ATDC	17°ATDC	
Valve clearance mm (inch)	Intake		[Hot] 0.20 (0.0079)	[Hot] 0.25 (0.0098)	[Hot] 0.27 (0.0101)	
	Exhaust		[Hot] 0.20 (0.0079)	[Hot] 0.25 (0.0098)	[Hot] 0.32 (0.0126)	
Idling speed rpm	Manual transmission		800 ± 50 (*1000 ± 50)	800 ± 50 (*1000 ± 50)	950 ± 50	
	Automatic transmission		850 ± 50 (*1000 ± 50)	—	—	
Blow-by gas recirculating system			Closed type	Closed type	Closed type	
Lubricating System	Lubricating method		Fully-forced feed method	Fully-forced feed method	Fully-forced feed method	
	Oil Pump type		Trochoid type	Trochoid type	Trochoid type	
	Oil filter type		Full-flow filter type, filter paper type	Full-flow filter type, filter paper type	Full-flow filter type, filter paper type	
	Lubrication oil capacity	Whole		3.2	3.2	3.3
		When only oil is changed		2.7	2.7	2.7
		When oil and oil filter are changed		3.0	3.0	3.1
Oil cooler type			Water-cooled type (only for tropical spec.)	Water-cooled type	Water-cooled type	
Super charger type			—	Turbocharger	Turbocharger	

* Swedish and Norwegian specifications.

GENERAL INFORMATION

Item		Engine type	CB-23	CB-61	CB-80		
Cooling System	Cooling method		Water cooled, electromotor type	Water cooled, electromotor type	Water cooled, electromotor type		
	Radiator type		Corrugation type forced circulation	Corrugation type forced circulation	Corrugation type forced circulation		
	Coolant capacity	Manual transmission	3.5 [Including 0.6 for reserve tank]	3.9 [Including 0.6 for reserve tank]	4.0 [Including 0.6 for reserve tank]		
		Automatic transmission	3.9 [Including 0.6 for reserve tank]	—	—		
	Water pump type		Centrifugal type, "V" belt-driven type	Centrifugal type, "V" belt-driven type	Centrifugal type, "V" belt-driven type		
	Thermostat type		Wax pellet type	Wax pellet type	Wax pellet type		
Air cleaner	Type		Filter paper type	Filter paper type	Filter paper type		
	Number		1	1	1		
Fuel System	Fuel tank	Capacity	Liter	37	40	40	
		Location		Mounted underneath rear seat floor	Mounted underneath rear seat floor	Mounted underneath rear seat floor	
	Fuel pipe material		Rubber and steel tube	Steel tube	Steel tube		
	Fuel pump type		Diaphragm type	Electromotor type	Electromotor type		
	Fuel filter type		Filter paper type	Filter paper type	Filter paper type		
	Carburetor	Manufacturer		Aisan kogyo	Aisan kogyo	—	
		Type		Two-barrel type	Two-barrel type	—	
		Throttle valve diameter	mm (inch)	28 (1.10), 32 (1.26)	28 (1.10), 32 (1.26)	—	
		Venturi diameter	mm (inch)	18 (0.71), 25 (0.98)	18 (0.71), 28 (1.10)	—	
		Choke valve type		Manual type, butterfly-shaped valve	Manual type, butterfly-shaped valve	—	
	Fuel injection device		—	—	Electronic type		
	Injection pump	Type		—	—	—	
		Injection timing		—	—	—	
		Plunger diameter	mm (inch)	—	—	—	
		Cam lift	mm (inch)	—	—	—	
		Type of self-aligner		—	—	—	
	Injection nozzle or injector	Type of nozzle retainer		—	—	With cushion rubber type	
Nozzle type		—	—	Electronic controlled throttle type			
Injection pressure		kg/cm ² (Psi)	—	—	2.55 (18.4)		
Engine electrical system	Ignition system	Voltage		V	12 [Negative ground]	12 [Negative ground]	12V [Negative ground]
		Type		Battery ignition type	Battery ignition type	Battery ignition type	
		Ignition timing		BTDC 5°±2°/Idling	BTDC 10°±2°/Idling	BTDC 10°±2°/Idling	
		Firing order		1-2-3	1-2-3	1-2-3	
		Distributor	Distributor type		Conventional type	Conventional type	Full-transistorized type
			Breaker type		Contact-point type	Contact-point type	—
			Performance of timing advancing mechanism	Centrifuga. type	0°/750 rpm, 10.5°/2,800 rpm	0°/750 rpm, 13.5°/3,000 rpm	Electronic timing advance
Vacuum type	0°/-100 mmHg, 11°/-320 mmHg	0°/-60 mmHg, 10°/-450 mmHg		Electronic timing advance			

*Plunger stroke: 0.87 ± 0.03 mm (0.035 ± 0.0012 inch)

WM-01014

GENERAL INFORMATION

Item		Engine type		CB-23				CB-61				CB-80	
		Manufacturer	DENSO	NGK		BOSCH	CHAMPION	DENSO	NGK	BOSCH	CHAMPION	DENSO	
Ignition system	Spark plug	Type	For ECE & EEC	W16EXR-U	BP5EA-L	BP5EY	WR8DC	RN-11YC	W16EXR-U W20EXR-U	BP5EY BP6EY	WR8DC WR7DC	RN-9YC RN-11YC	W20ETR-L
			Except for ECE & EEC	W16EX-U	BP5EA-L	BP5EY	WR8DC (X,Y)	N-11YC	W16EX-U W20EX-U	BP5EY BP6EY	WR8DC (X,Y) WR7DC (X,Y)	N-9YC N-11YC	W20ET-L
		Thread		M14 × 1.25				M14 × 1.25				M14 × 1.25	
		Spark plug gap mm (inch)		0.7 - 0.8 (0.028 - 0.031)	0.8 - 0.9 (0.031 - 0.035)	0.7 - 0.8 (0.028 - 0.031)		0.7 - 0.8 (0.028 - 0.031)	0.7 - 0.8 (0.028 - 0.031)	0.8 - 0.9 (0.032 - 0.035)	0.7 - 0.8 (0.028 - 0.031)		0.9 - 1.0 (0.035 - 0.039)
		Glow plug		Type	—				—				—
		Voltage, current	V-A				—				—		
Engine electrical system	Battery	Type	General specifications		34B17L *155B24L				34B17L *155B24L				34B17L *155B24L
			ECE & EEC specifications		55B24L				55B24L				55B24L
			Australian specifications		34B17L				34B17L				—
		Capacity AH	General specifications		27 (5HR), *136 (5HR)				27 (5HR), *136 (5HR)				27 (5HR), *136 (5HR)
			ECE & EEC specifications		36 (5HR)				36 (5HR)				36 (5HR)
			Australian specifications		27 (5HR)				27 (5HR)				—
	Alternator	Type	3-Phase alternating current commutating type				3-Phase alternating current commutating type				3-Phase alternating current commutating type		
		Output	V-A				12-45, *512-50				12-45	12-50	
		Regulator type	Contact-pointless type				Contact-pointless type				Contact-pointless type		
	Starter	Type	Magnet engaging type				Magnet engaging type				Magnet engaging type		
Output		V-kw				*212-0.7, *312-0.8, **12-1.0				12-0.8, **12-1.0	12-0.8, *312-1.0		
Radio noise suppressing device		Resistive cord				Resistive cord				Resistive cord			

*1 Option
 *2 General & Australian specifications mounted with manual transmission
 *3 ECE & EEC specifications mounted with manual transmission
 *4 Vehicles mounted with automatic transmission
 *5 Norwegian specifications with automatic transmission mounted model



DAIHATSU
TYPE CB
ENGINE

[CB-23, CB-61 & CB-80]

SECTION 2
THE ENGINE PROPER

ENGINE SECTIONAL VIEWS	2- 2
CB-23	2- 2
CB-61	2- 4
CB-80	2- 6
ENGINE COMPONENTS AND	
TIGHTENING TORQUE	2- 8
CB-23 and CB-61	2- 8
CB-80	2- 9
MAIN SERVICE SPECIFICATIONS	2-10

WM-02001

ENGINE SECTIONAL VIEWS

CB-23

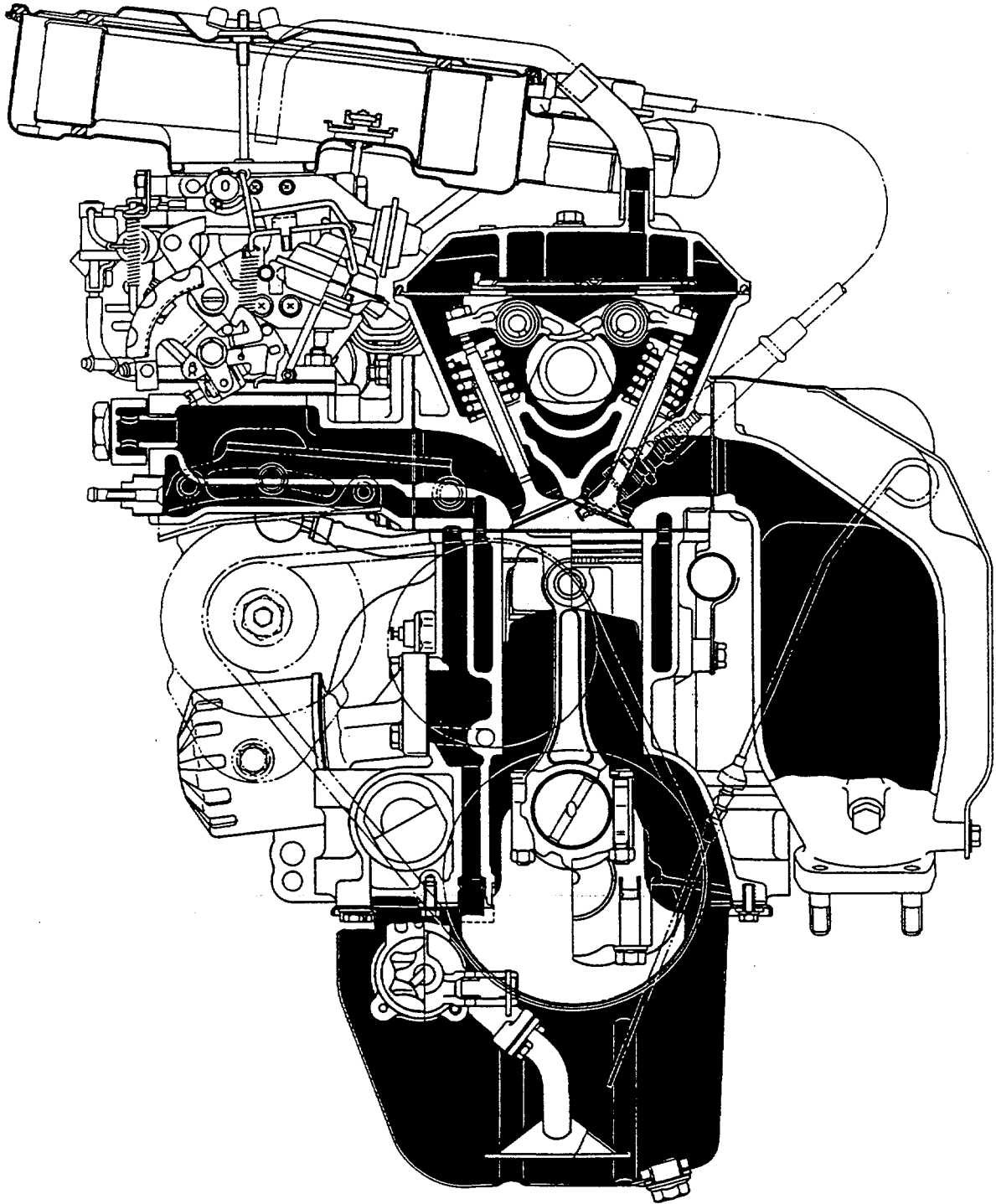

Fig. 2-1

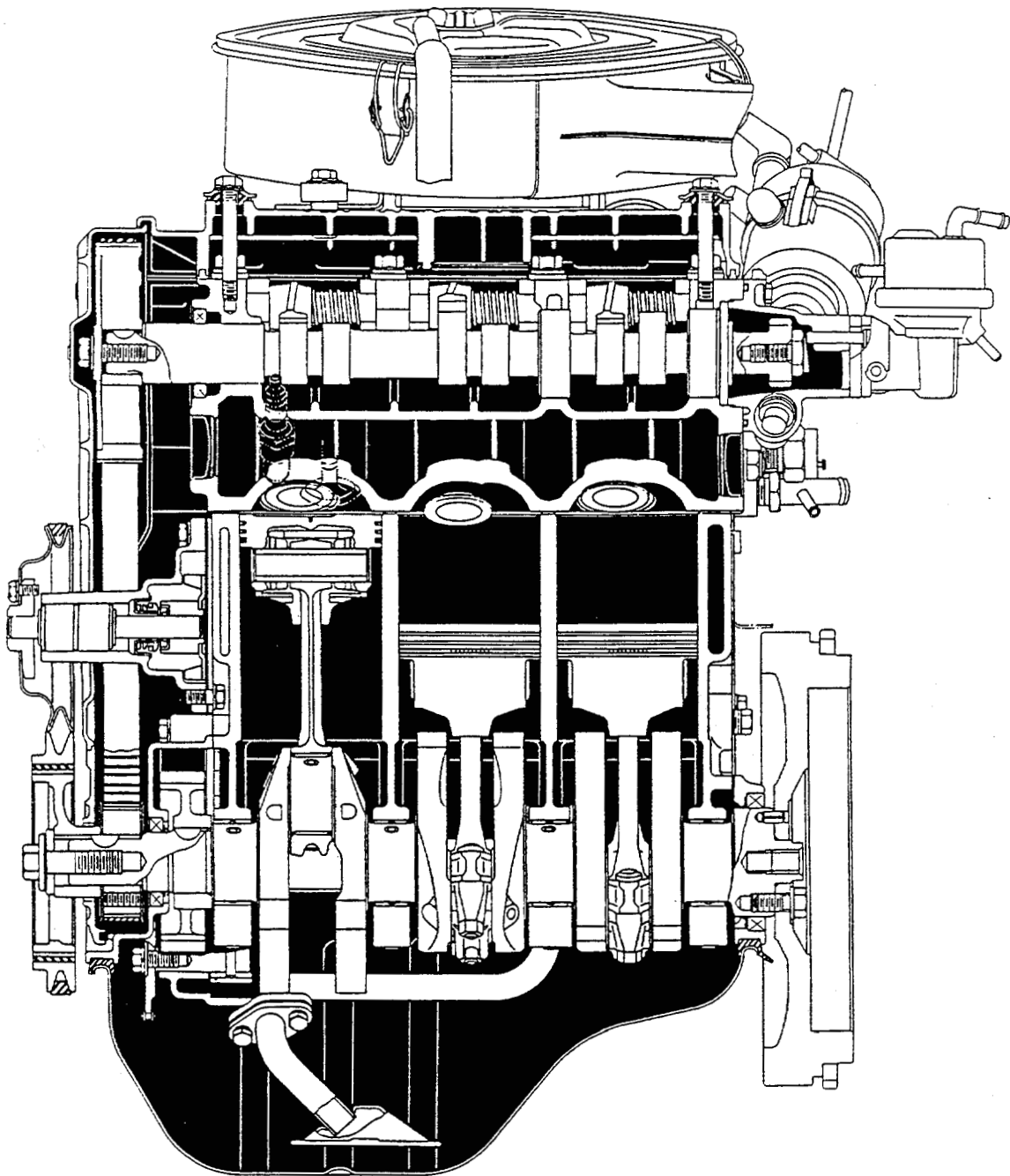

Fig. 2-2

WM-02003

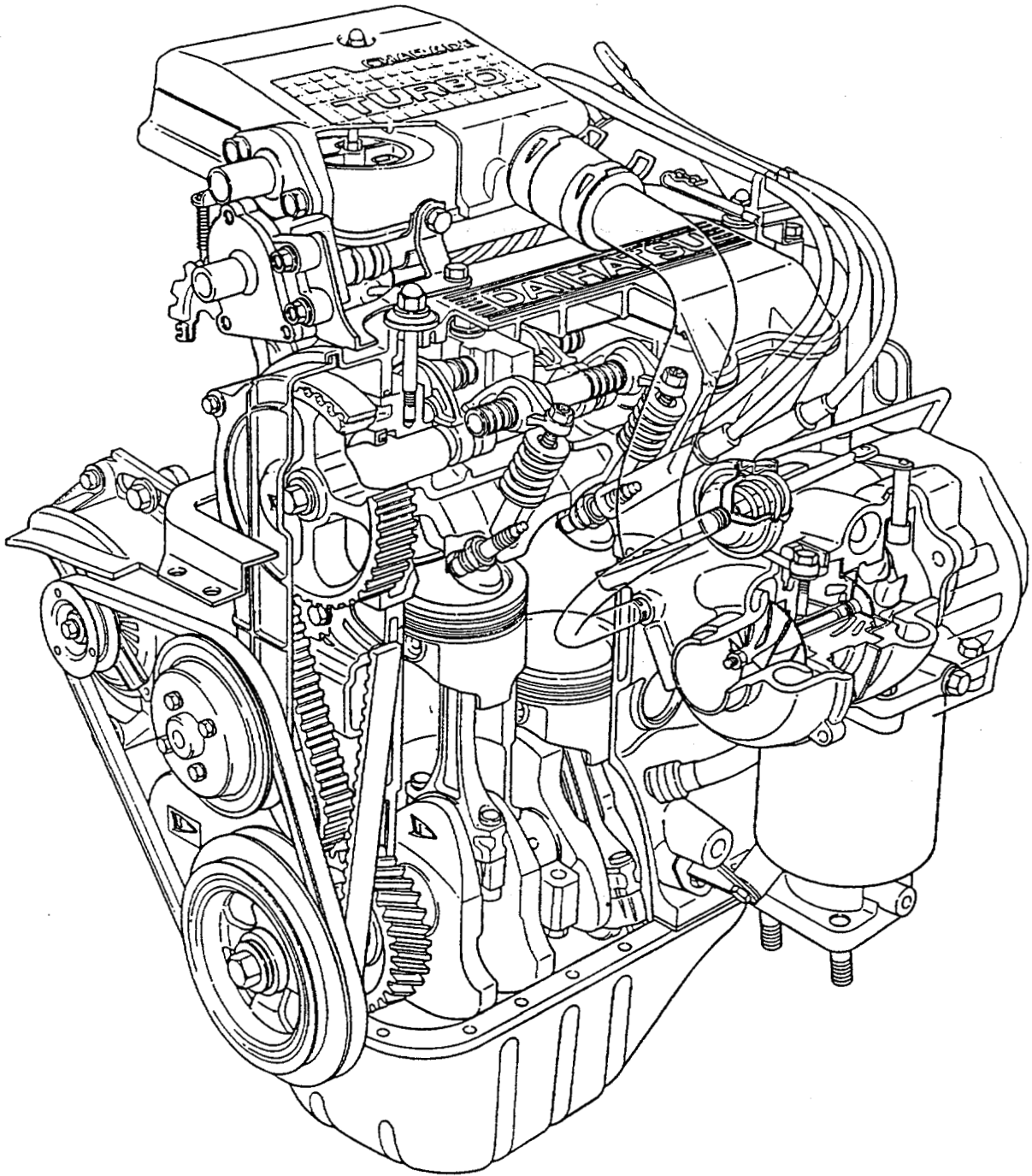

Fig. 2-3

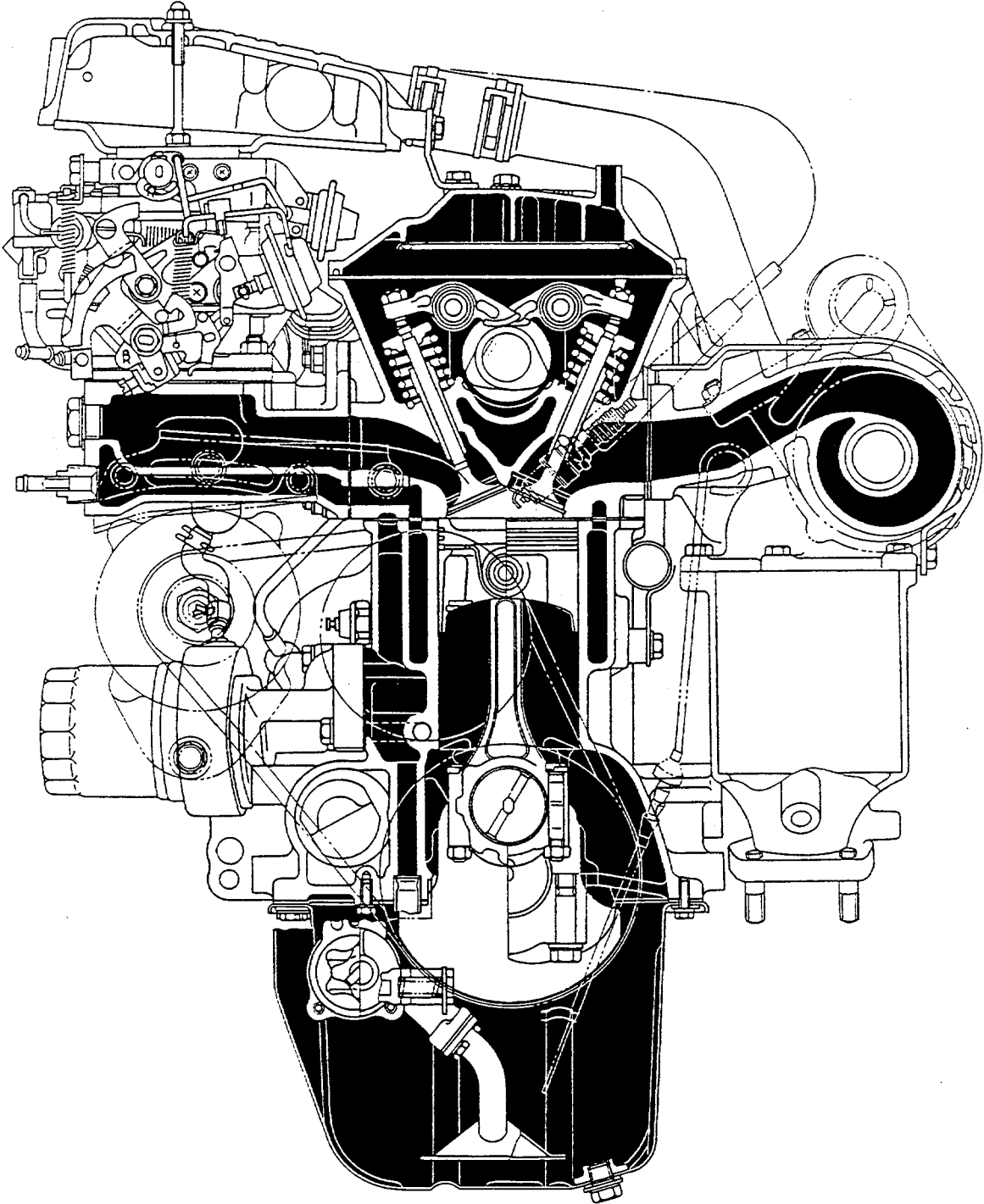

Fig. 2-4

WM-02005

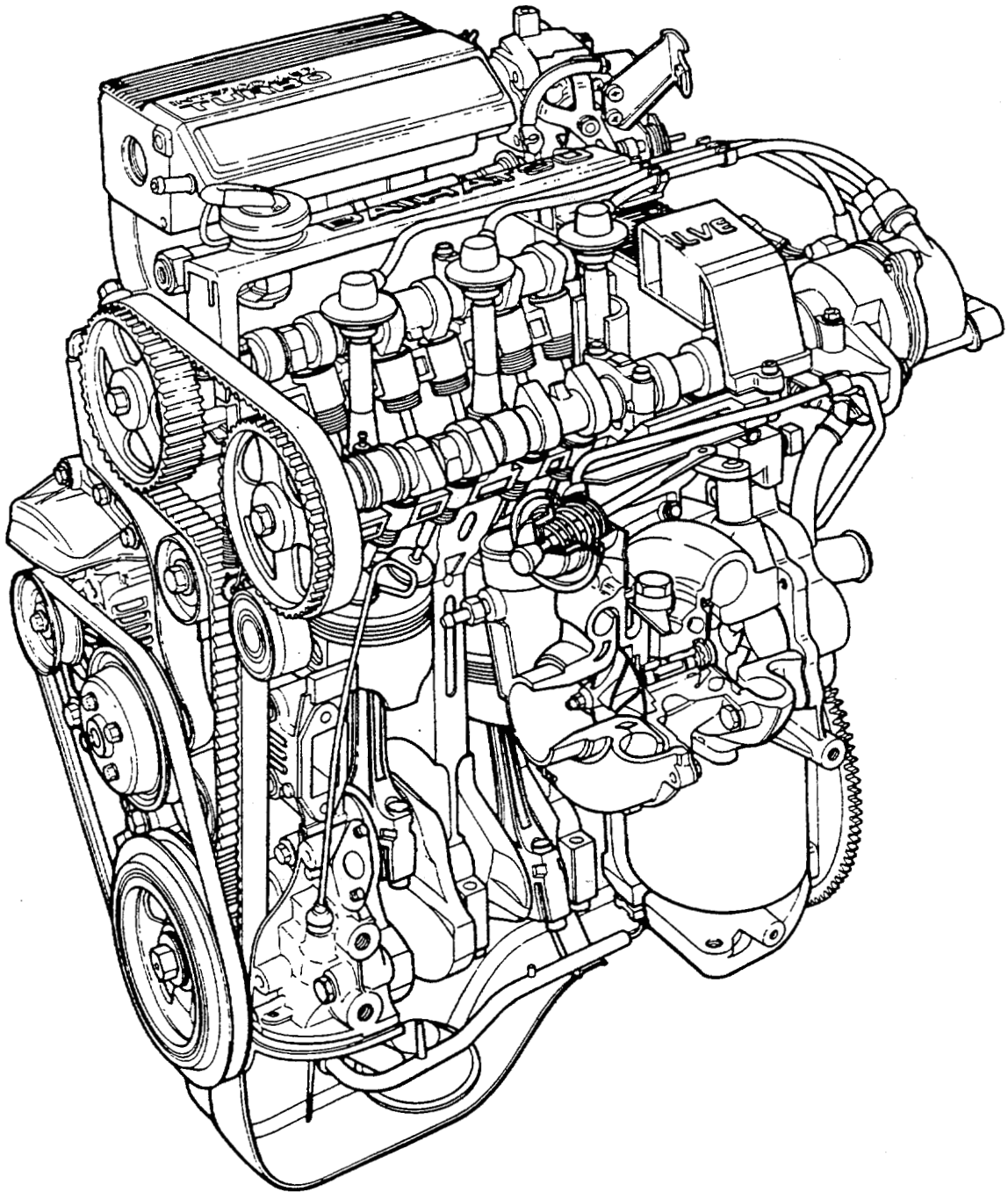

Fig. 2-5

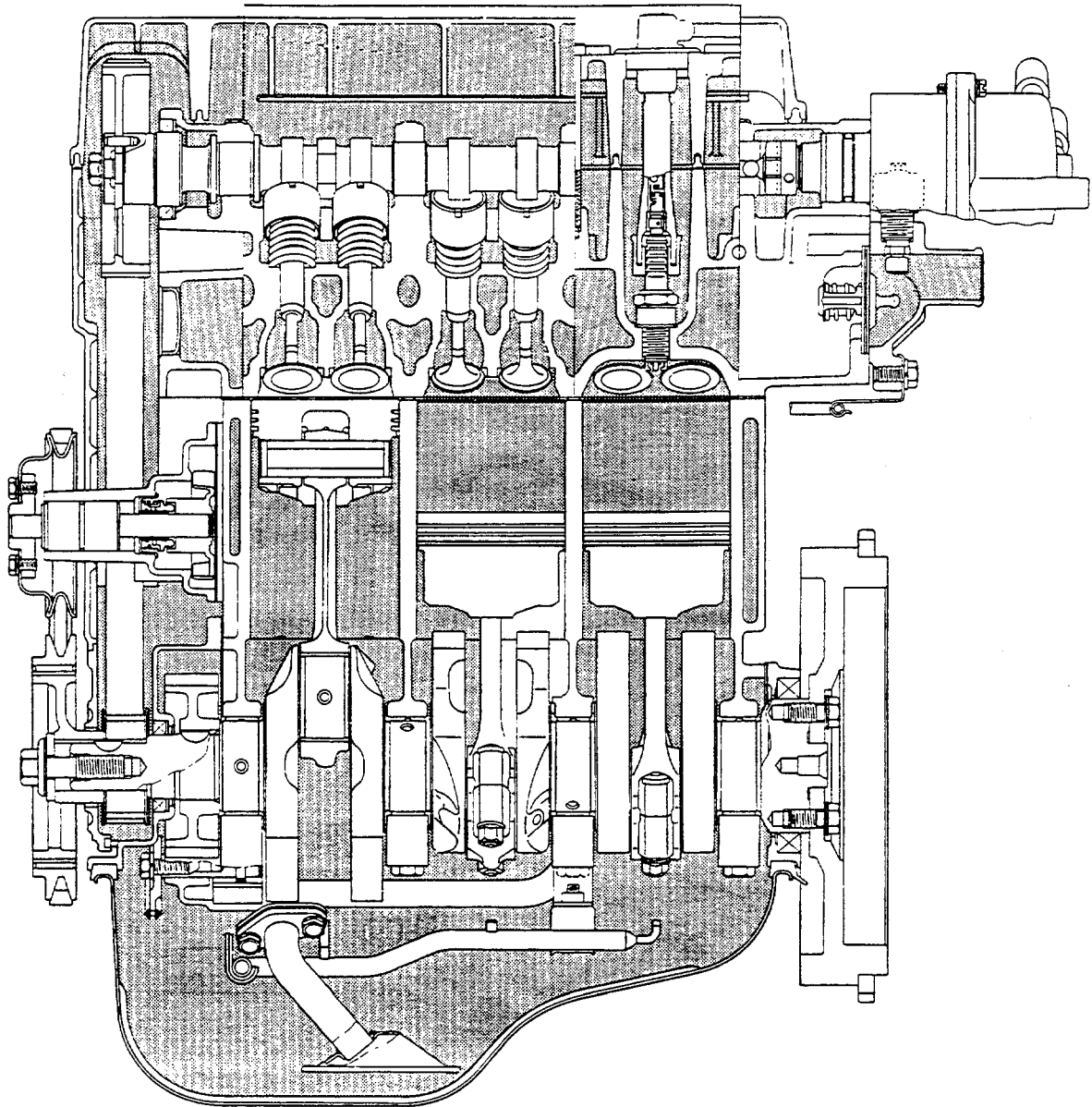

Fig. 2-6

WM-02007

THE ENGINE PROPER

ENGINE COMPONENTS AND TIGHTENING TORQUE

CB-23 and CB-61

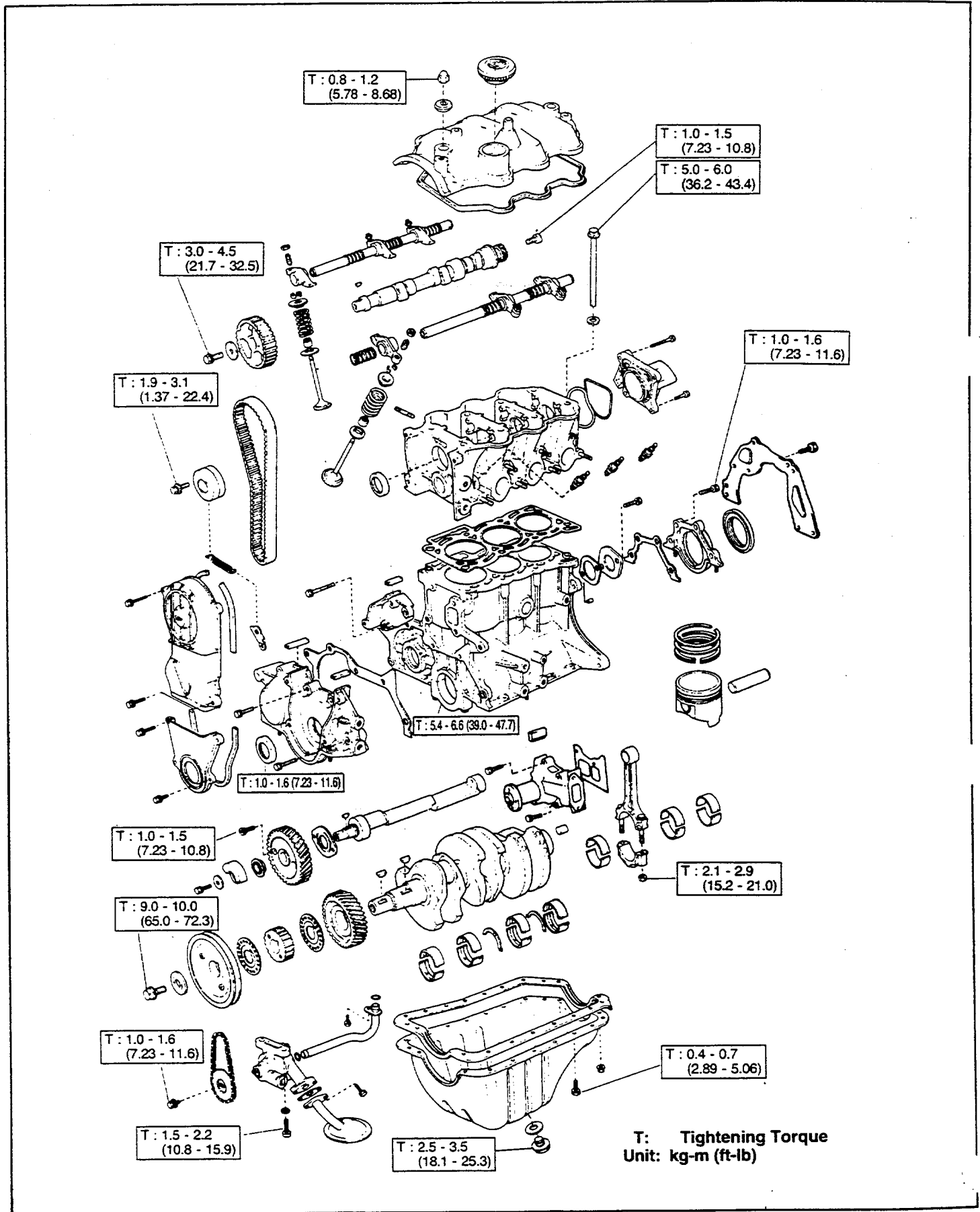

Fig. 2-7

WM-02008

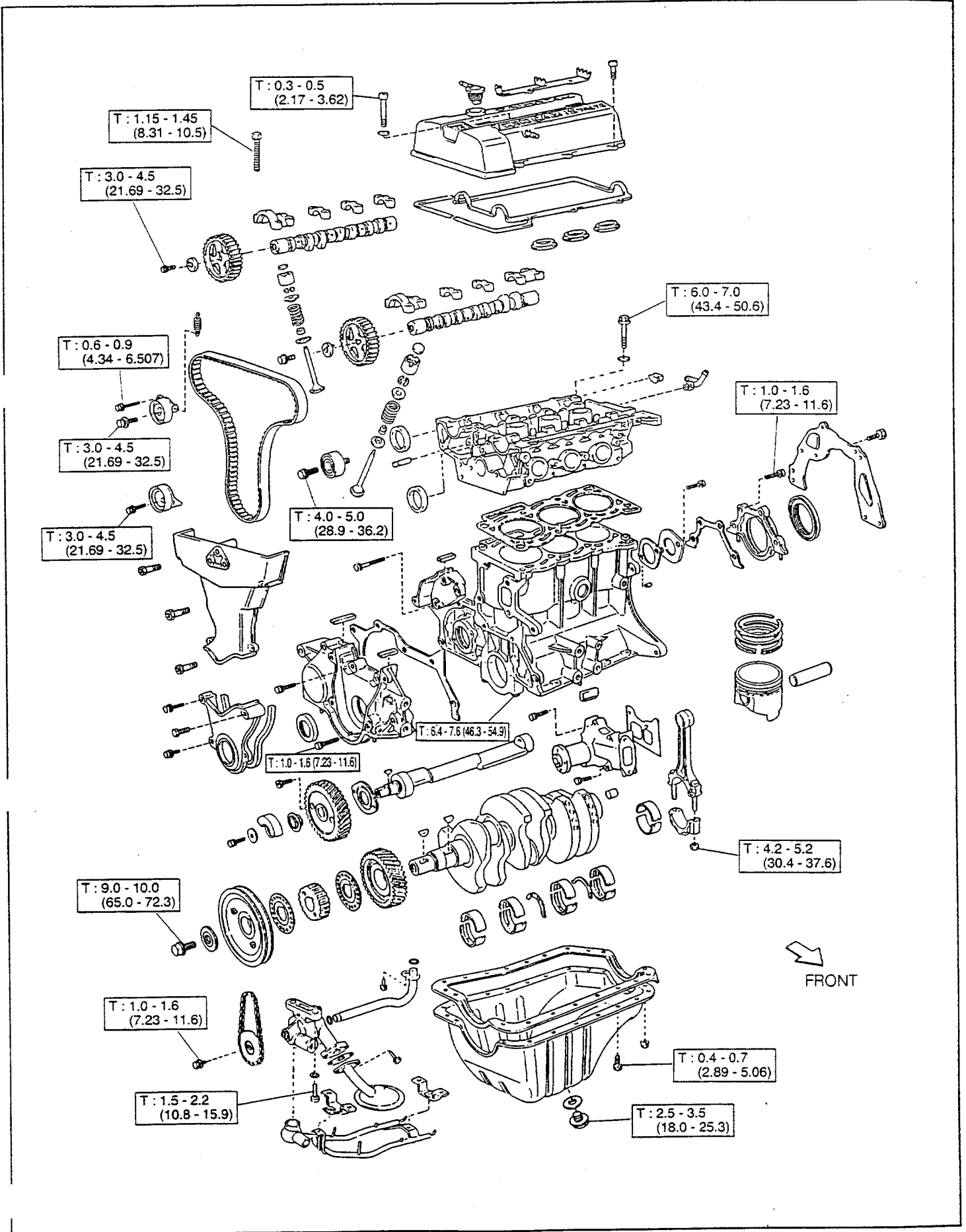

Fig. 2-8

THE ENGINE PROPER

MAIN SERVICE SPECIFICATIONS

Item		Specified value										Remarks
Engine type		CB-23					CB-61				CB-80	
Idling speed rpm		* ^{M/T} 800 ± 50 ^{A/T} 850 ± 50					*800 ± 50				950 ± 50	
CO concentration %	General specifications	0.5 - 1.5					0.5 - 1.5				0.5 - 1.5	
	ECE & EEC Specifications											
	Australian, Swedish and Swiss specifications											
Compression pressure kg/cm ² -rpm (psi-rpm)	Specified value	12.5/350 (177.8/350)					12.0/350 (170.7/350)				10.5/300 (149.3/300)	
	Allowable limit	10.5/350 (149.4/350)					10.5/350 (149.4/350)				8.5/300 (121/300)	
	Difference between cylinders	Within 1.5 (21.3)					Within 1.5 (21.3)				Within 1.5 (21.3)	
Valve clearance [Hot] mm (inch)	Intake	0.20 (0.0079)					0.25 (0.0098)				0.27 (0.0101)	
	Exhaust	0.20 (0.0079)					0.25 (0.0098)				0.32 (0.0126)	
Lubrication oil capacity ℓ	Total capacity	3.2					3.2				3.3	
	Oil pan capacity (F level)	2.7					2.7				2.7	
	Oil pan capacity (L level)	1.7					1.7				1.7	
Float level mm (inch)		22 (0.87)					22 (0.87)				—	Measured from top surface of body
Radiator cap valve opening pressure kg/cm ² (psi)	Specified value	0.75 - 1.05 (10.7 - 14.9)					0.75 - 1.05 (10.7 - 14.9)				0.75 - 1.05 (10.7 - 14.9)	
	Allowable limit	0.6 (8.5)					0.6 (8.5)				0.6 (8.5)	
Radiator leak check pressure kg/cm ² (psi)		1.2 (17)					1.2 (17)				1.2 (17)	
V-belt deflection mm/kg (inch/lb)		5-7/10 (0.20-0.28/22.1)					5-7/10 (0.20-0.28/22.1)				7.5-8.5/8 (0.30-0.33/17.6)	
Cooling water capacity ℓ	Total capacity (A/T)	3.5 (3.9)					3.9				4.0	Including 0.6 for reserve tank
	Reserve tank capacity	0.6					0.6				0.6	
Anti-freezing solution filling capacity ℓ	-10°C (23%)	0.66 (M/T), 0.76 (A/T) [0.14]					0.75 [0.14]				0.77 [0.14]	[] Filling amount for reserve tank
	-20°C (35%)	1.00 (M/T), 1.14 (A/T) [0.21]					1.14 [0.21]				1.14 [0.21]	
	-35°C (50%)	1.44 (M/T), 1.64 (A/T) [0.30]					1.64 [0.30]				1.68 [0.30]	
Distributor	Dwell angle	58° - 66°					58° - 66°				—	
	Heel gap mm (inch)	0.4 - 0.5 (0.016 - 0.020)					0.4 - 0.5 (0.016 - 0.020)				—	
Spark plug	Manufacturer	DENSO		NGK		BOSCH		CHAMPION		DENSO		
	For ECE & EEC	W16EX-U	BP35EA-L	BP35EY	WR8DC	N-11YC	W16EX-U	BP35EY	WR8DC	N-9YC	W20ET-L	W22ET-L
	Except for ECE & EEC	W16EX-U	BP35EA-L	BP35EY	WR8DC (X,Y)	N-11YC	W16EX-U	BP35EY	WR8DC (X,Y)	N-9YC	W20ET-L	W22ET-L
	Spark plug gap mm (inch)	0.7 - 0.8 (0.028 - 0.031)		0.8 - 0.9 (0.031 - 0.036)		0.7 - 0.8 (0.028 - 0.031)		0.7 - 0.8 (0.028 - 0.031)		0.7 - 0.8 (0.028 - 0.031)		0.9 - 1.0 (0.035 - 0.039)
Ignition timing	Manual transmission	BTDC 5° ± 2° 800 ± 50 rpm					BTDC 10° ± 2° 800 ± 50 rpm				BTDC 10° 950 ± 50 rpm	
	Automatic transmission	BTDC 5° ± 2° 850 ± 50 rpm					—				—	

*1000 rpm ± 50 for day-light specification vehicles (CB-23 and CB-61 only)

WM-020*

DAIHATSU
TYPE CB
ENGINE

[CB-23, CB-61 & CB-80]

3

SECTION 3
ENGINE TUNE-UP

ENGINE TUNE-UP PROCEDURE	3- 2
ENGINE TUNE-UP [CB-23 and CB-61]	3- 6
ENGINE TUNE-UP [CB-80]	3-19

WM-03001

ENGINE TUNE-UP

ENGINE TUNE-UP PROCEDURE

NOTE:

The operation enclosed by heavy lines is described in the main text.

Checking cooling water level and engine oil level

Specified value:
Cooling water capacity:
(including reserve tank capacity of 0.6 liter)

Item \ Engine type	CB-23	CB-61	CB-80
Manual transmission	3.5	3.9	4.0
Automatic transmission	3.9	—	—

Specified value:
Engine oil capacity:

Item \ Engine type	CB-23	CB-61	CB-80
When only oil is changed	2.7	2.7	2.7
When oil and oil filter are changed	3.0	3.0	3.1

Specified value:
Radiator cap opening pressure:
0.75 - 1.05 kg/cm² (1.7 - 2.3 psi)

Checking battery electrolyte level and specific gravity

Specified value:
Battery electrolyte specific gravity:
(at electrolyte temperature of 20°C)
1.27 to 1.29 (34B-17L)

[NOTE]

The vehicles mounted with a maintenance-free battery should be checked by a battery checker

Checking and cleaning air cleaner

Checking and adjusting spark plugs

.... Spark Plug Specifications

Engine type	CB-23				CB-61				CB-80		
Manufacturer	DENSO	NGK		BOSCH	CHAMPION	DENSO	NGK	BOSCH	CHAMPION	DENSO	
ECE & EEC	W16EXR-U	BPR5EA-L	BPR5EY	WR8DC	RN-11YC	W16EXR-U W20EXR-U	BPR5EY BPR6EY	WR8DC WR7DC	RN-9YC RN-11YC	W20ET-L	W22ET-L
Except for ECE & EEC	W16EX-U	BP5EA-L	BP5EY	WR8DC (X,Y)	N-11YC	W16EX-U W20EX-U	BP5EY BP6EY	WR8DC (X,Y) WR7DC (X,Y)	N-9YC N-11YC	W20ET-L	W22ET-L
Spark plug gap mm (inch)	0.7 - 0.8 (0.028 - 0.031)		0.8 - 0.9 (0.031 - 0.036)	0.7 - 0.8 (0.028 - 0.031)		0.7 - 0.8 (0.028 - 0.031)	0.8 - 0.9 (0.032 - 0.036)	0.7 - 0.8 (0.028 - 0.031)		0.9 - 1.0 (0.035 - 0.039)	

Checking resistive cords

.... Specified value:

Item	Engine type		
	CB-23	CB-61	CB-80
Cord No.1	6.8 - 10.0	6.8 - 10.0	3.2 - 4.8
Cord No.2	8.1 - 12.1	8.1 - 12.1	4.6 - 7.0
Cord No.3	8.1 - 12.1	8.1 - 12.1	7.0 - 10.3
Center cord	6.1 - 9.2	6.1 - 9.2	5.1 - 7.7

kΩ

Checking and adjusting V-belt for deflection

.... Specified deflection:
Cooling water capacity:
(including reserve tank capacity of 0.6 liter)

Item	Engine type		
	CB-23	CB-61	CB-80
V-belt deflection	5-7/10 (0.20-0.28/22.1)	5-7/10 (0.20-0.28/22.1)	7.5-8.5/8 (0.30-0.33/17.6)

mm/kg (inch/lb)

Checking cylinder head and manifolds for tightening condition

.... Specified value:
Cylinder head tightening torque & Manifold tightening torque

Item	Engine type		
	CB-23	CB-61	CB-80
Cylinder head tightening torque	5.5 - 6.5 (40 - 47)	5.5 - 6.5 (40 - 47)	6.0 - 7.0 (43 - 51)
Exhaust manifold tightening torque	1.0 - 1.6 (7 - 12)	1.0 - 1.6 (7 - 12)	4.0 - 5.0 (29 - 36)
Intake manifold tightening torque	1.0 - 1.6 (7 - 12)	1.0 - 1.6 (7 - 12)	1.7 - 2.5 (29 - 36)

kg-m (ft-lb)

Warming-up engine
(Cooling water temperature: 75 to 80°C)

Checking valve clearances

.... Specified clearance:
(Clearance between cam and rocker arm)

Item	Engine type		
	CB-23	CB-61	CB-80
IN (When hot)	0.20 (0.0079)	0.25 (0.0098)	0.27 (0.0101)
EX (When hot)	0.20 (0.0079)	0.25 (0.0098)	0.32 (0.0126)

mm (inch)

[NOTE]

"HOT" denotes a period during which the engine block temperature is above 80°C (176°F) after the vehicle has been warmed up completely.

ENGINE TUNE-UP

Checking compression pressure

Item	Engine type	kg/cm ² (psi)		
		CB-23	CB-61	CB-80
Specified value (350 rpm)		12.5 (177.8)	12.0 (170.7)	10.5 (300 rpm) (149.3 - 300 rpm)
Minimum requirement (350 rpm)				8.5 (300 rpm) (121 - 300 rpm)
Difference between cylinders				

Checking and adjusting distributor
(Except CB-80)

Specified value:

Item	Engine type	CB-23	CB-61
		Heel gap mm (inch)	0.4 - 0.5 (0.016 - 0.020)
Dwell angle (°)		58 - 66	58 - 66

Checking and adjusting ignition timing

Specified value:

Item	Engine type	CB-23	CB-61	CB-80
		Ignition timing	BTDC 5°±2°/lding	BTDC 10°±2°/lding

Checking idle speed

Specified value:

[NOTE]

Make sure that no additional electrical load such as headlamps is applied to the engine.

Item	Engine type	rpm		
		CB-23	CB-61	CB-80
Manual transmission		800 ± 50 (1000 ± 50)	800 ± 50 (1000 ± 50)	950 ± 50
Automatic transmission		850 ± 50 (1000 ± 50)	—	—

() Swedish and Norwegian specifications.

Measuring CO concentration

Specified value:

Item \ Engine type	CB-23	CB-61	CB-80
CO concentration	1 ± 0.5%	1 ± 0.5%	1 ± 0.5%

NOTE: For Swiss specifications, be sure to cut off the EGR operation.

Not conformed to specifications

4. Adjusting idling speed

Checking and adjusting fast idle speed
(Except CB-80)

Specified speed:

Item \ Engine type	CB-23	CB-61
Engine speed (rpm)	2000 ± 200	2600 ± 200

NOTE: Pull the choke button out as far as it will go and depress the accelerator pedal once or twice.

Checking and adjusting dashpot

Specified speed:

Item \ Engine type	CB-23	CB-61	CB-80
General specifications	1600 ± 50	1600 ± 50	1600 ± 100
Swiss & Australian specifications	1300 ± 50	1300 ± 50	1600 ± 100
Australian & West German specifications	1300 ± 50	1300 ± 50	1600 ± 100

rpm

Checking choke opener for operation
(Except CB-80)

WM-C3005

ENGINE TUNE-UP

ENGINE TUNE-UP [CB-23 and CB-61]

Connecting Method of Instruments and Handling Instructions

1. Engine tachometer
 - (1) In the case of a tachometer in which the pick-up is made from the primary circuit and there is no 3-cylinder range, carry out the measurement using the 6-cylinder range. And multiply the reading by 2. This product is the actual revolutionary speed of the 3-cylinder engine.
 - (2) In the case of a tachometer in which the pulses flowing through the resistive cord of the cylinder No.1 are sensed, the reading can be read directly regardless of the number of cylinders.
2. The power supply for the tachometer, timing light and other instruments should be connected to the battery terminal.
3. Never disconnect the battery terminals while the engine is running.
(Failure to observe this caution will cause abnormal pulses to apply to the transistors, even leading to damage of the transistors and other electronic meters, etc.)
4. Care must be exercised to ensure that no water gets to each electric part during the cleaning.
5. Make sure that the CO meter is adjusted and calibrated accurately before it is put into use.
 - (1) Warming-up
 - (2) Zero-point adjustment
 - (3) Span adjustment

WM-03006

Checking engine oil level

After the engine has warmed up, stop the engine. A few minutes later, check the engine oil level using a level gauge.

Ensure that the oil level is between the full level and the low level.

Engine Oil Capacity

Item \ Engine type	CB-23	CB-61
Full level	2.7	2.7
Low level	1.7	1.7

NOTE:

When the engine oil level is below the specified level, replenish the specified oil to the full level.

(When the engine oil level is below the specified level, check to see if oil leakage exists.)

2. Checking cooling water level

Check the cooling water level at the reserve tank. Ensure that the cooling water level is between the full level and the low level.

NOTE:

When the cooling water level is below the specified level, replenish the reserve tank with water to the full level.

If the cooling water level is below the low level, remove the radiator cap and check the radiator cooling water for correct level.

If the cooling water level is always below the specified level, check the radiator cap and water leakage, using a radiator cap tester.

CAUTION:

Never open the radiator cap when the engine is running or when the cooling water is still hot.

Cooling water capacity

CB-23	Manual transmission-equipped vehicle.	3.5 ℓ (Including 0.6 ℓ for reserve tank)
	Automatic transmission-equipped vehicle.	3.9 ℓ (Including 0.6 ℓ for reserve tank)
CB-61	3.9 ℓ (Including 0.6 ℓ for reserve tank)	

WM-03009

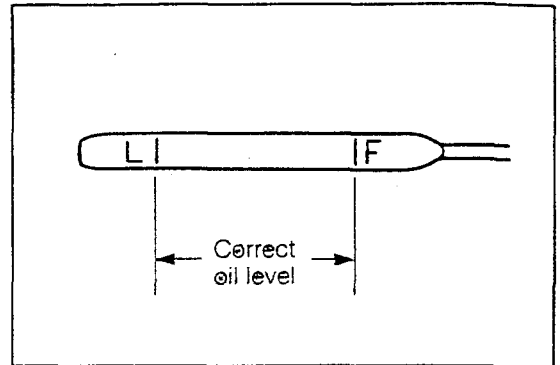

Fig. 3-1

WM-03007

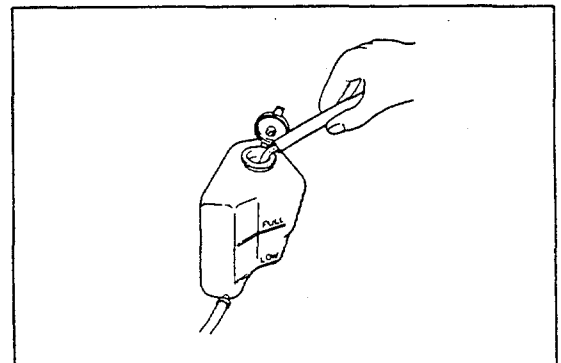

Fig. 3-2

WM-03008

ENGINE TUNE-UP

3. Checking air cleaner element

(1) Visually inspect to see if the air cleaner element is restricted, abnormally dirty or damaged.

NOTE:

Replace the air cleaner element, as required.

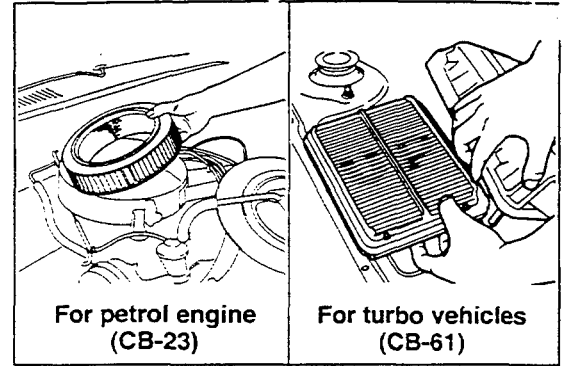

Fig. 3-3

WM-03010

(2) Clean the element with compressed air. Blow compressed air from the inside or up side of the air cleaner element.

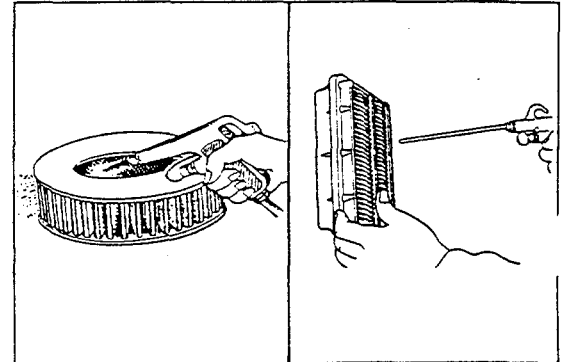

Fig. 3-4

WM-03011

4. Checking spark plugs

(1) Visually inspect the spark plugs for damage or cracks.

NOTE:

Replace the spark plug, as required.

(2) Clean the spark plugs.

(3) Check and adjust the spark plug gaps.

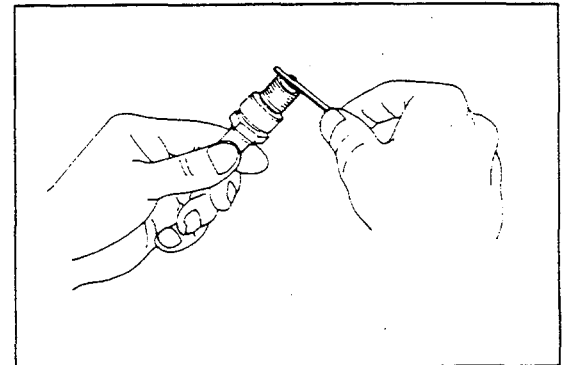

Fig. 3-5

WM-03012

Specified Spark Plug Gap

Engine type	CB-23					CB-61			
	DENSO	NGK		BOSCH	CHAMPION	DENSO	NGK	BOSCH	CHAMPION
ECE & EEC specifications	W16EXR-U	BPR5EA-L	BPR5EY	WR8DC	RN-11YC	W16EXR-U W20EXR-U	BPR5EY BPR6EY	WR8DC WR7DC	RN-9YC RN-11YC
Except ECE & EEC specifications	W16EX-U	BP5EA-L	BP5EY	W8DC (X,Y)	N-11YC	W16EX-U W20EX-U	BP5EY BP6EY	W8DC (X,Y) W7DC (X,Y)	N-9YC N-11YC
Spark plug gap mm (inch)	0.7 - 0.8 (0.028 - 0.031)		0.8 - 0.9 (0.031 - 0.036)	0.7 - 0.8 (0.028 - 0.031)		0.7 - 0.8 (0.028 - 0.031) 0.8 - 0.9 (0.032 - 0.036)		0.7 - 0.8 (0.028 - 0.031)	

WM-03013

Checking V-belt

(1) Visually inspect to see if the V-belt exhibits damage, cracks or wear.

NOTE:

Replace the V-belt, as required.

(2) Measure the amount of belt deflection.

Specified Deflection of V-Belt:

5 - 7 mm (0.20 - 0.28 inch)

[With a force of 8 kg (17.64 lb) Applied]

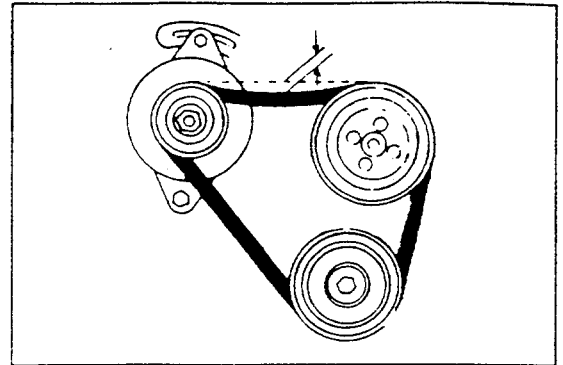

Fig. 3-6

WM-03014

6. Checking valve clearances

Warm up the engine.

Cooling water temperature: 75 - 85°C (167 - 185 °F)

Check and adjust the valve clearances.

Specified Valve Clearance:

CB-23: 0.20 ± 0.05 mm (0.0079 ± 0.002 inch)

CB-61: 0.25 ± 0.05 mm (0.0098 ± 0.002 inch)

Both for Intake and Exhaust Valves

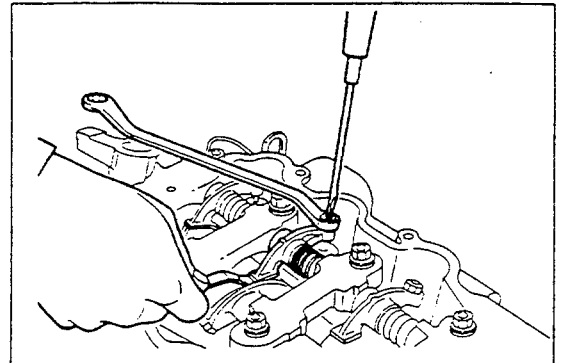

Fig. 3-7

WM-03015

NOTE:

Carry out the check and adjustment of valve clearances, with the piston of the No.1 cylinder set to the end of the compression stroke or to the tops of the intake and exhaust strokes, respectively. See the table at the right for the adjustable valves for the respective positions of the No.1 piston.

Crank angle	Cylinder		
	1	2	3
When No.1 piston is set to end of compression stroke	IN	○	—
	EX	○	○
When No.1 piston is set to tops of intake and exhaust strokes, respectively	IN	—	○
	EX	—	○

WM-03016

7. Checking compression pressure

kg/cm² (psi) at 350 rpm

CB-23	10.5 - 12.5 (149.4 - 179.3)
CB-61	10.5 - 12.0 (149.4 - 172.7)

NOTE:

The compression pressure check should be performed with all spark plugs removed. Also, be sure to keep both the throttle valve and choke valve fully opened during the check.

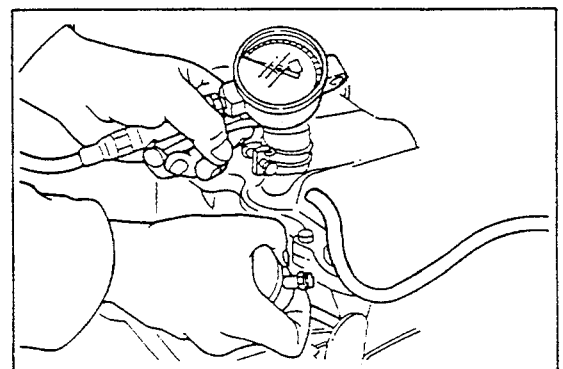

Fig. 3-8

WM-03017

The measurement of compression pressure should be performed for a short period of time. Moreover, care must be exercised to ensure that the measurement time for each cylinder becomes equal.

If the specified pressure is not met, check to see if the cylinder-to-piston clearance conforms to the specification. Also check the piston rings for wear.

WM-03018

ENGINE TUNE-UP

8. Checking contact points

- (1) Check to see if the contact points exhibit the trace of burning.
- (2) Check and adjust the gap of the contact points.

Specified Heel Gap:

0.4 - 0.5 mm (0.016 - 0.020 inch)

[Referential Information]

Specified Contact Point Gap:

0.4 - 0.5 mm (0.016 - 0.020 inch)

Specified Dwell Angle: 58° - 66°

9. Checking ignition timing

- (1) Disconnect the vacuum hose from the vacuum advancer. Plug the disconnected vacuum hose. Using a timing light, check the ignition timing while idling the engine.

Specified Ignition Timing:

Manual transmission

BTDC 5° ± 2°/800 ± 50 rpm

Automatic transmission

BTDC 5° ± 2°/850 ± 50 rpm

Daylight system-equipped vehicle

BTDC 5° ± 2°/1,000 ± 50 rpm

NOTE:

Upon completion of the ignition timing check, be certain to install the clutch housing cover on the inspection window.

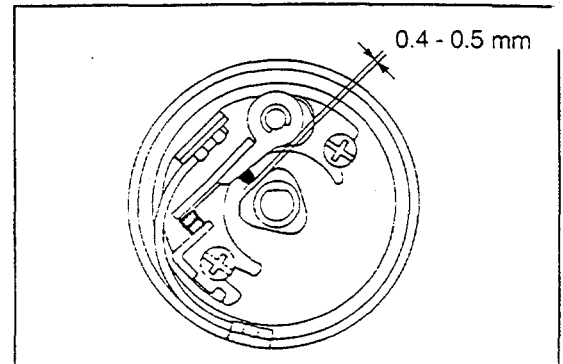

Fig. 3-9

WM-03019

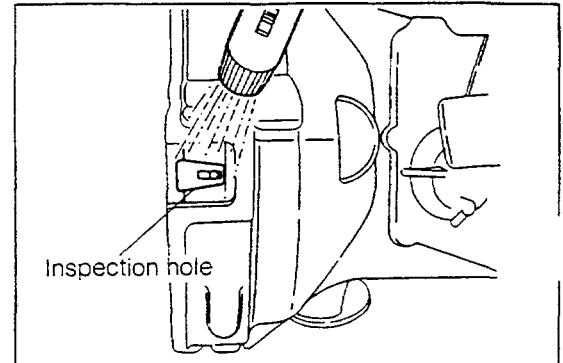

Fig. 3-10

WM-03020

10. Adjustment

- (1) The ignition timing can be adjusted by slacking the retaining bolt of the distributor flange and then by turning the distributor body.

NOTE:

When the distributor body is turned counterclockwise, the ignition timing is advanced. Conversely, when the distributor body is turned clockwise, the ignition timing is retarded.

- (2) After the adjustment has been completed, reconnect the auxiliary vacuum hose to the vacuum advancer. Ensure that the engine revolution speed rises about 50 to 100 rpm. Also ensure that the engine is emitting a normal sound.

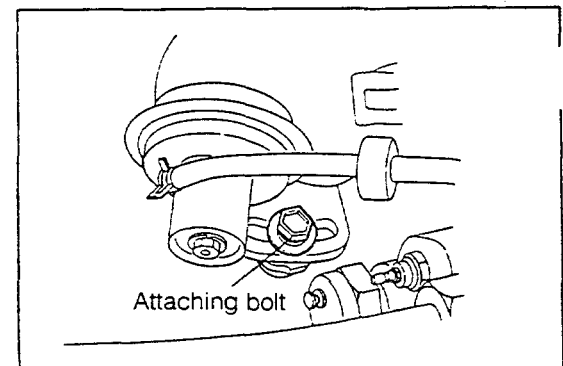

Fig. 3-11

WM-03021

WM-03022

- (3) Securely tighten the retaining bolt of the distributor. Care must be exercised to ensure that the distributor body does not turn during this tightening operation.
Specified Tightening Torque:
 1.5 - 2.2 kg-m (10.8 - 15.9 ft-lb)

WM-03023

11. Checking ignition advance

- (1) Disconnect the vacuum hose and plug the disconnected hose. Accelerate the engine repeatedly. Using a timing light, check to see whether the governor ignition advance is taking place.

NOTE:

Prior to starting this test, disconnect the vacuum hose. Make sure to plug the disconnected hose.

- (2) Apply a negative pressure to the vacuum advancer by means of a MityVac or by sucking the hose. Ensure that the ignition mark moves in the ignition advance direction.
- (3) Reconnect the vacuum hose in the original position.

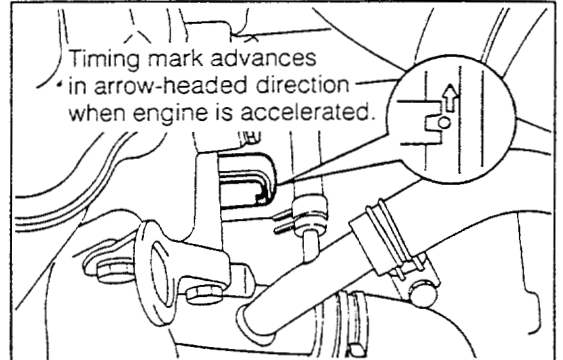

Fig. 3-12

WM-03024

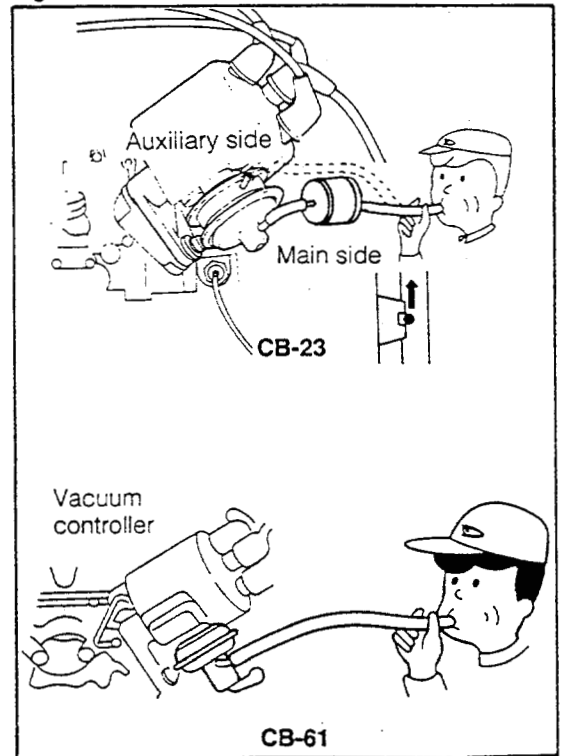
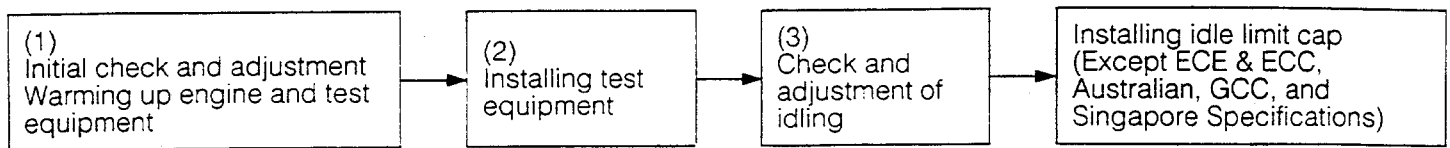

Fig. 3-13

WM-03025

ENGINE TUNE-UP

12. Checking idle speed



WM-03026

(1) Precaution

The following notes must be observed before or during the idle speed adjustment.

- ① Warm up the engine thoroughly
- ② Do not perform the engine idling speed adjustment while the fan motor is functioning.
- ③ Never apply extra loads such as the headlamps, rear window defogger or the like during the adjustment of the engine idle speed. (On the day light-equipped vehicle, keep the headlamps glowing.)
- ④ Be sure to install the air cleaner element in place.
- ⑤ Be sure to disconnect the HIC (Hot Idle Compensator) hose and plug the disconnected hose.
- ⑥ Ensure that the choke valve opens fully.
- ⑦ Ensure that the exhaust system exhibits no gas leakage.
- ⑧ Ensure that the intake system exhibits no air leakage.
- ⑨ The idle limit cap can be removed by cutting it off with pliers or the like. (Except the ECE & EEC, Australian, GCC, Singapore specifications) After the adjustment has been completed, be sure to install a new cap. Make sure that it can rotate freely.
- ⑩ The shape of the idle limit cap for the ECE & EEC, Australian, GCC, Singapore specifications differs from that of other specifications. Use the following SST to adjust the cap.
SST: 09243-00020
- ⑪ On those vehicles whose air cleaner is equipped with a vacuum motor, disconnect the vacuum motor hose and plug the disconnected hose.

WM-03027

(2) Initial check and adjustment

- ① Warm up the engine, until the cooling water temperature becomes 75°C - 85°C (167 - 185°F). (As for a guide for this temperature, you may use a point when the fan motor stops running. The idling should not be adjusted while the fan motor is operating.)
- ② Warm up the CO meter.
- ③ If the engine is equipped with a plastic idle limit cap, remove it.
- ④ Ensure that the choke valve opens fully.

(3) Test equipment installation

Install an engine tachometer to the engine.

WM-03028

(4) Check and adjustment of idle speed

• Manual transmission-equipped vehicle

- ① Back off the idling adjusting screw the specified turns from the fully closed position.
Specified backing-off turn:
CB-23 4¾ turns
CB-61 7 turns
- ② Start the engine. Turn the throttle adjusting screw, until the engine runs at 850 rpm.
- ③ Screw in the idle adjusting screw, until the engine runs at 800 rpm.
Specified Idling Speed: 800 ± 50 rpm

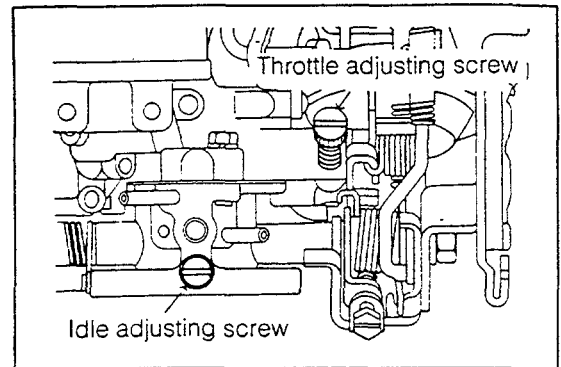

Fig. 3-14

WM-03029

• Automatic transmission-equipped vehicle

- ① Back off the idle adjusting screw about 4¾ turns from the fully-closed position.
- ② Start the engine. Turn the throttle adjusting screw, until the engine runs at 950 rpm.
- ③ Screw in the idle adjusting screw, until the engine runs at 850 rpm.
Specified Idling Speed: 850 ± 50 rpm
(For Day-Light Relay-equipped vehicle: 1000 ± 50 rpm)

NOTE:

On those engines for ECE & EEC Australian, GCC and Singapore specifications, screw in the idle adjusting screw, using a SST (09243-00020).

WM-03030

• Except AS (secondary air suction) system-equipped vehicle

(As for the AS system-equipped vehicle, see the next section.)

- ④ Measure the CO concentration.

Specified CO concentration:

General specifications:	5 - 6 %
ECE & EEC specifications:	0.5 - 1.5 %

- ⑤ If the CO concentration does not conform to the specified values, turn the idle adjusting screw. If the engine rotates roughly, check to see if the CO concentration or engine revolution speed drops excessively. Set these values to higher points within the allowable ranges.

WM-03032

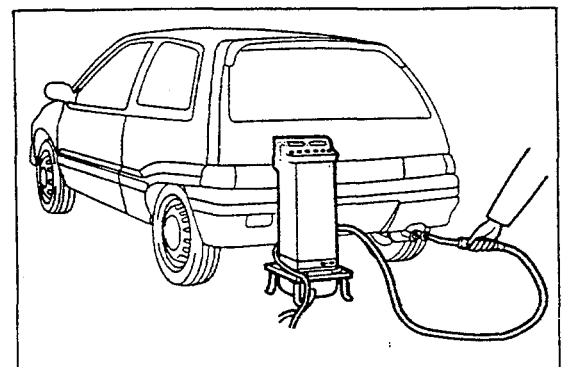

Fig. 3-15

WM-03031

ENGINE TUNE-UP

• AS (secondary air suction) system-equipped vehicle

(Australian, and West German specifications)

- ④ Measure the CO concentration.
 - (1) Disconnect the hose between the air cleaner and the air suction valve. Plug the disconnected hose.
 - (2) Leave the engine idling for about 10 minutes.
 - (3) Check the CO concentration.
Specified CO Concentration:
Not to exceed 1.0 %
- ⑤ If the measured concentration does not conform to the specified value, perform the idle adjustment described below.

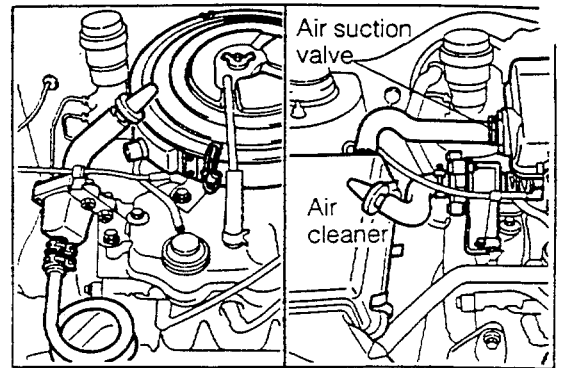

Fig. 3-16

WM-03033

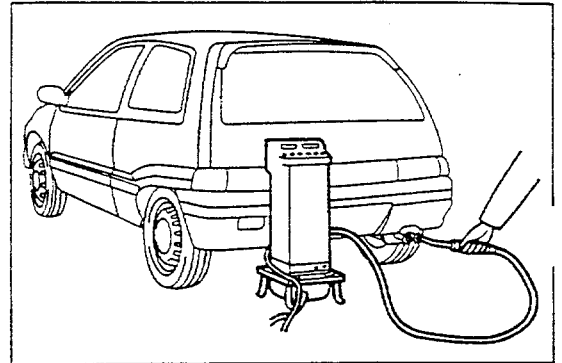

Fig. 3-17

WM-03034

(5) Idle limit cap installation

Install the idle limit cap in the original position. (This applies to those engines equipped with a plastic idle limit cap.)

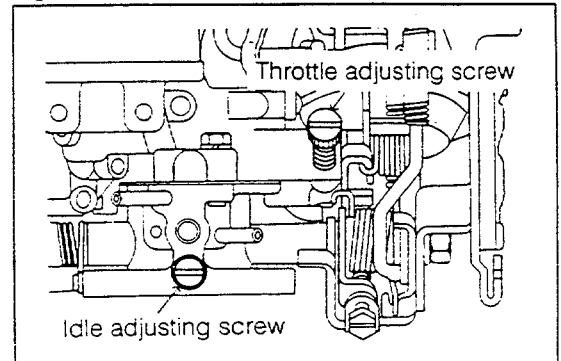

Fig. 3-18

WM-03035

(6) Idle adjustment

- ① Back off the idle adjusting screw the specified turns from the fully-closed state.
Specified Value:
CB-23: About 5 1/4 Turns
CB-61: About 7 Turns
- ② Turn the throttle adjusting screw to set the idling to the specified speed
Specified idling speed:
Manual Transmission: 800 ± 50 rpm
Automatic Transmission: 850 ± 50 rpm

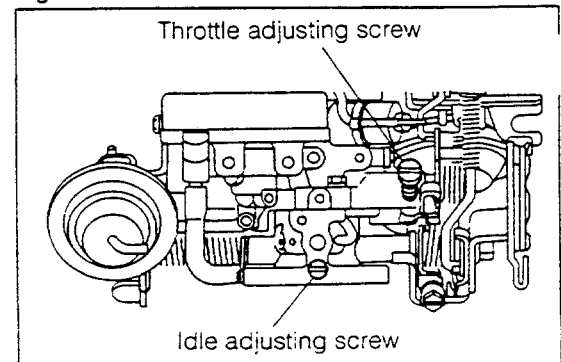

Fig. 3-19

WM-03036

- ③ Remove the air suction valve.

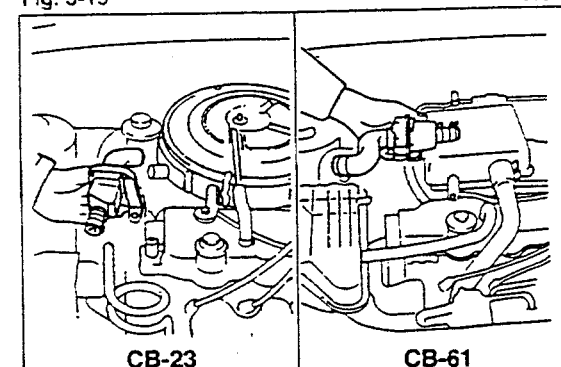

Fig. 3-20

WM-03037

- ④ Insert the sampling pipe into the air suction pipe. Plug the gap between the air suction pipe and the sampling pipe, using heat-resistant tape or the like.

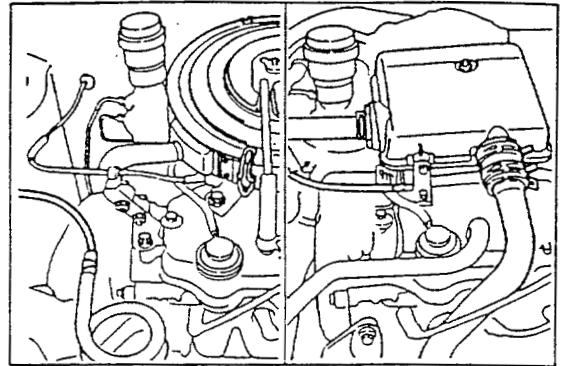

Fig. 3-21

WM-03038

- ⑤ Measure the CO concentration.
Specified CO Concentration:
Swiss specifications:
Not to exceed $1.5 \pm 0.5 \%$
Australian specifications:
Not to exceed $1.0 \pm 0.5 \%$
West German specifications:
Not to exceed $1.5 \pm 0.5 \%$

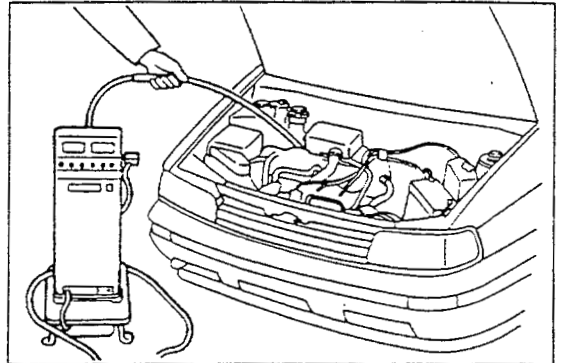

Fig. 3-22

WM-03039

- ⑥ If the idling speed does not conform to the specified value, adjust the idle speed by the throttle adjusting screw.

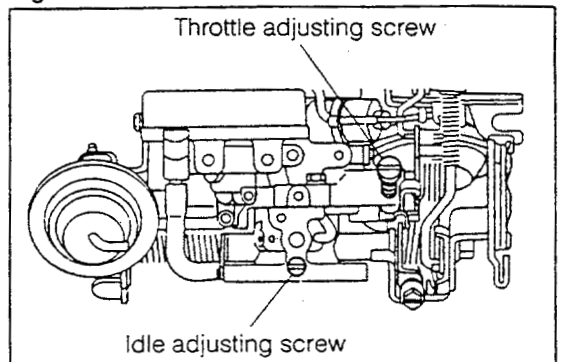

Fig. 3-23

WM-03040

- ⑦ At this time, if the engine rotates roughly, recheck the CO concentration and check to see if the engine rotational speed is too low. Set the CO concentration to 0.5 to 1.5%.

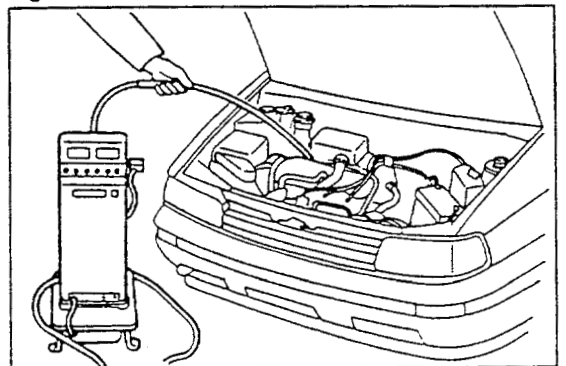

Fig. 3-24

WM-03041

- ⑧ Reinstall the AS valve in the original position.

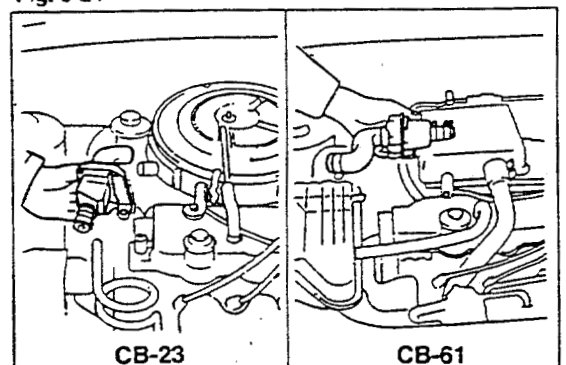

Fig. 3-25

WM-03042

ENGINE TUNE-UP

- ⑨ Ensure that the CO concentration decreases.

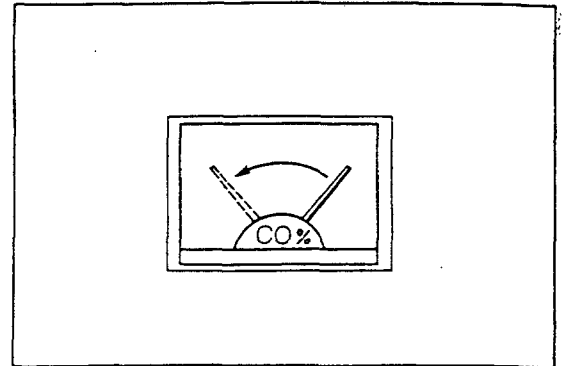

Fig. 3-26

WM-03043

- ⑩ Ensure that the engine revolution speed is within the specified idle speed.

Specified idle speed:

Manual transmission-equipped vehicle:

800 ± 50 rpm

Automatic transmission-equipped vehicle:

850 ± 50 rpm

13. Checking fast idle speed

Check

- (1) Warm up the engine.
(Temperature of coolant 75 - 85°C)
- (2) Stop the engine and pull the choke button out as far as it will go. Depress the accelerator pedal once or twice. Restart the engine.
- (3) After starting the engine, ensure that the choke opener is functioning and that the fast idle adjusting lever rests on the second stage of the fast idle cam
- (4) Check the engine revolution speed.

Specified Fast Idling Speed:

CB-23: 1800 - 2200 rpm

CB-61: 2400 - 2800 rpm

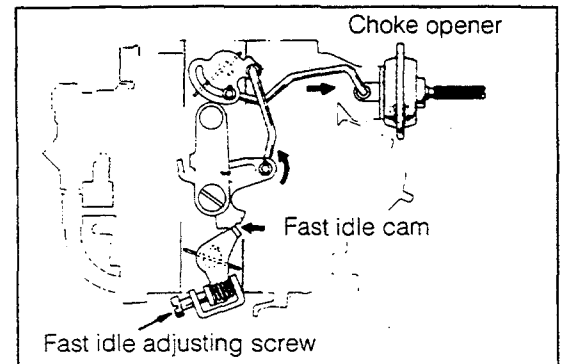

Fig. 3-27

WM-03045

- (5) Ensure that the engine returns to its idling speed, when the choke button is pushed back to the original position.

NOTE:

The operations described in the steps (3) and (4) should be carried out for a short period of time.

Adjustment

The fast idling speed can be adjusted by turning the fast idle adjusting screw.

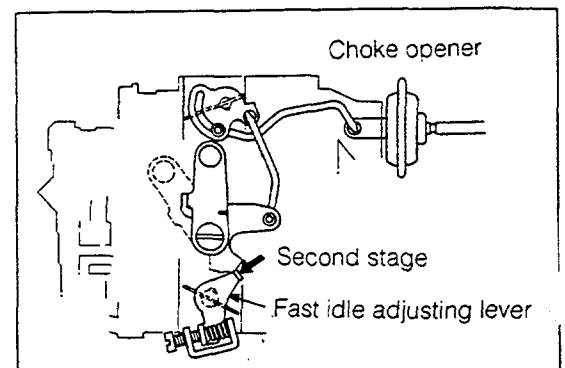

Fig. 3-28

WM-03046

**Checking dashpot
(Dashpot-equipped vehicle only)**

(1) Touch revolution speed check

- ① Start the engine. Disconnect the vacuum hose ① from the diaphragm pipe ②.
- ② Open the throttle so that the throttle touch arm ③ may be held separated from the diaphragm shaft ④.
- ④ Plug the diaphragm pipe by finger.
- ③ Release the throttle valve. Measure the engine revolution speed at a time when the throttle touch arm begins to contact the diaphragm shaft. If this engine speed falls within the following range, it indicates that the system is functioning properly.
Touch Revolution Speed: 1200 - 1400 rpm

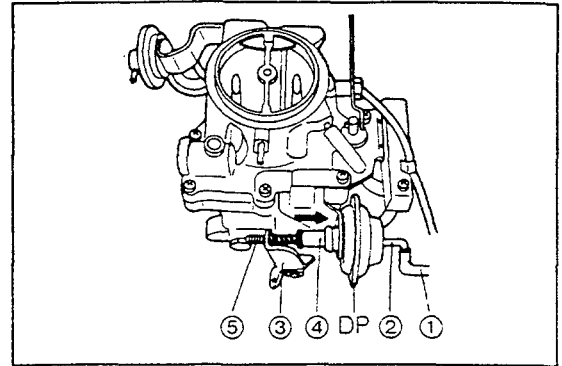

Fig. 3-29

WM-03047

(2) Adjustment

- ① Turn the adjusting screw ⑤ so that the specified revolution speed is obtained.
- ② Upon completion of the adjustment, reconnect the vacuum hose. Ensure that the engine revolution speed drops to the idle speed.

(3) Dashpot function check

- ① Keep the engine revolution speed at 2500 rpm for a short period of time. Then, release the throttle valve.
- ② Measure the time required for the engine to drop its engine revolution speed from the touch revolution speed to the idle revolution speed.
Specified Time Required: 0.5 - 5.0 seconds

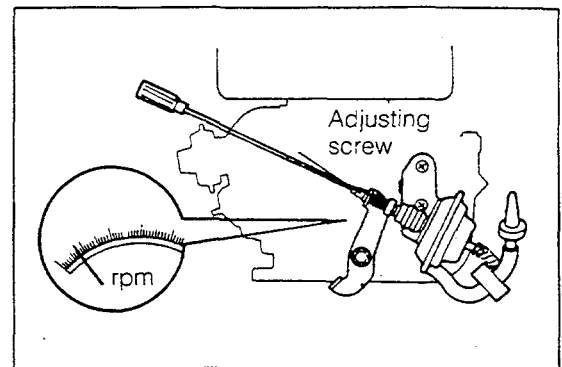

Fig. 3-30

WM-03048

- (4) If the measured time does not conform to the specified value, check the dashpot for air tightness. Also check the VTV and replace them as required.

15. Checking choke opener

(Choke opener-equipped vehicle only)

While the engine is idling, disconnect the vacuum hose connected to the choke opener. If the link functions in the way as described in the table below, it represents that the choke opener is functioning properly.

Cooling water temperature	When hose is reconnected, link moves. (Negative pressure is applied.)
29°C or above	

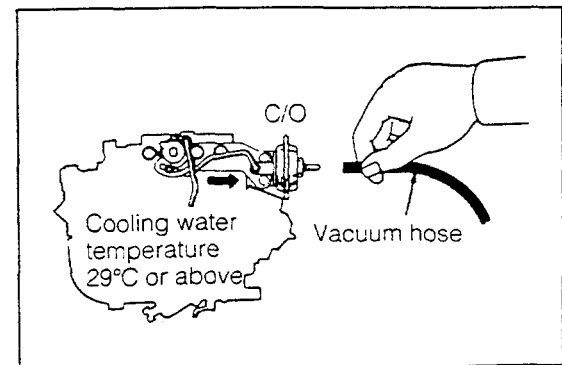

Fig. 3-31

WM-C3050

If the link will not move, check the BVSV, TVSV or choke opener. Replace them, as required.

REFERENTIAL INFORMATION

Simple Checking Method of Valve Timing

The valve timing can be checked easily at a time when the piston of the No.1 cylinder is set to the top dead center at the end of the compression stroke for the purpose of checking and adjusting valve clearances. The following is the procedure for this simple checking method of valve timing.

Checking Procedure

1. Turn the crankshaft, until the ignition mark on the flywheel is aligned with the ignition mark of the No.1 cylinder.
2. When the operation described in the step 1 has been made, check to see whether the check mark on the timing belt cover is lined up with the timing mark on the camshaft pulley, as indicated in the illustration at the right.

When these marks are aligned to each other, the valve timing is correct.

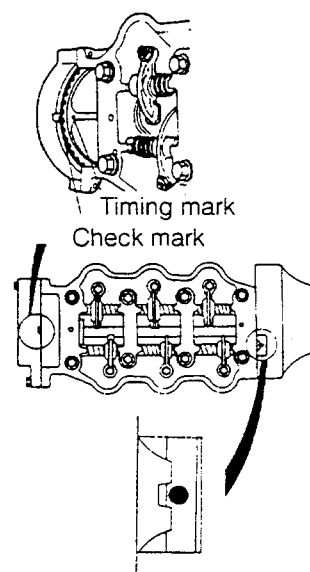

WM-03049

ENGINE TUNE-UP [CB-80]**CONNECTING METHOD OF INSTRUMENTS AND HANDLING INSTRUCTIONS**

1. Engine tachometer
 - (1) In the case of a tachometer in which the pick-up is made from the primary circuit and there is no 3-cylinder range, carry out the measurement using the 6-cylinder range. And multiply the reading by 2. This product is the actual revolutionary speed of the 3-cylinder engine.
 - (2) In the case of a tachometer in which the pulses flowing through the resistive cord of the cylinder No.1 are sensed, the reading can be read directly regardless of the number of cylinders.
2. The power supply for the tachometer, timing light and other instruments should be connected to the battery terminal.
3. Never disconnect the battery terminals while the engine is running.
(Failure to observe this caution will cause abnormal pulses to apply to the transistors, even leading to damage of the transistors and other electronic meters, etc.)
4. Care must be exercised to ensure that no water gets to each electric part during the cleaning.
5. Make sure that the CO meter is adjusted and calibrated accurately before it is put into use.
 - (1) Warming-up
 - (2) Zero-point adjustment
 - (3) Span adjustment

WM-03051

ENGINE TUNE-UP

1. Checking engine oil level

After the engine has warmed up, stop the engine. A few minutes later, check the engine oil level using a level gauge.

Ensure that the oil level is between the full level and the low level.

Engine Oil Capacity:

Full level 2.7

Low level 1.7

NOTE:

When the engine oil level is below the specified level, replenish the specified oil to the full level.

(When the engine oil level is below the specified level, check to see if oil leakage exists.)

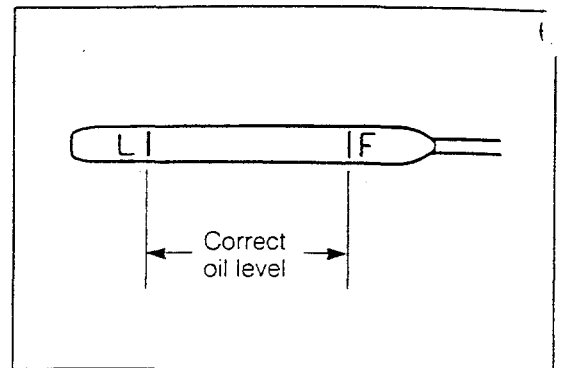

Fig. 3-32

WM-03052

2. Checking cooling water level

Check the cooling water level at the reserve tank. Ensure that the cooling water level is between the full level and the low level.

NOTE:

When the cooling water level is below the specified level, replenish the reserve tank with water to the full level.

If the cooling water level is below the low level, remove the radiator cap and check the radiator cooling water for correct level.

If the cooling water level is always below the specified level, check the radiator cap and water leakage, using a radiator cap tester.

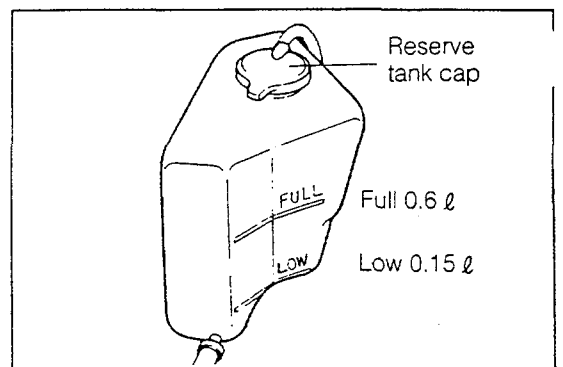

Fig. 3-33

WM-03053

CAUTION:

Never open the radiator cap when the engine is running or when the cooling water is still hot.

Cooling water capacity: 4.0 ℓ

(Including 0.6 ℓ for reserve tank)

3. Checking air cleaner element

(1) Visually inspect to see if the air cleaner element is restricted, abnormally dirty or damaged.

NOTE:

Replace the air cleaner element, as required.

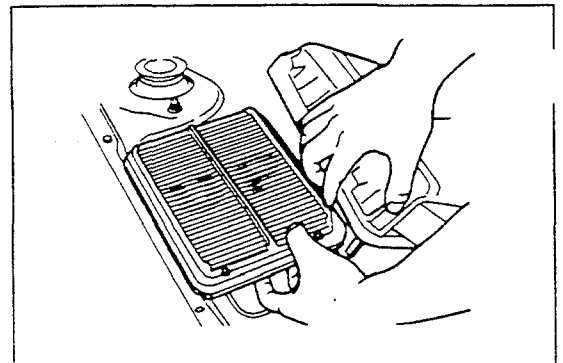

Fig. 3-34

WM-03054

(2) Clean the element with compressed air.

Blow compressed air from the upper of the air cleaner element.

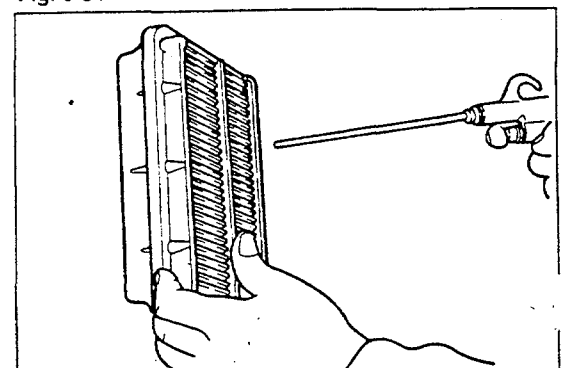

Fig. 3-35

WM-03055

Checking spark plugs

(1) Visually inspect the spark plugs for damage or cracks.

NOTE:

Replace the spark plug, as required.

(2) Clean the spark plugs.

(3) Check and adjustment of the spark plug gaps.

Specified Spark Plug Gap:

0.9 - 1.0 mm (0.035 - 0.039 inch)

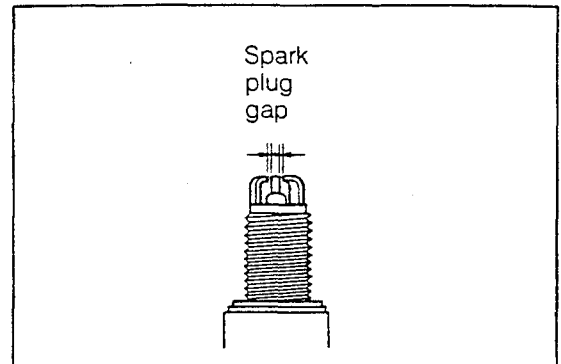

Fig. 3-36

WM-03056

(4) If the spark plug is burnt excessively, replace it with a replacement plug.

Manufacturer	DENSO	
ECE & EEC specifications	W22ETR-L	W20ETR-L
Except ECE & EEC specifications	W22ET-L	W20ET-L

WM-03057

5. Checking V-belt

(1) Visually inspect to see if the V-belt exhibits damage, cracks or wear.

NOTE:

Replace the V-belt, as required.

(2) Measure the amount of belt deflection.

Specified Deflection of V-Belt

7.5 - 8.5 (0.3 - 0.35 inch)

[With a force of 8 kg (18 lb) Applied]

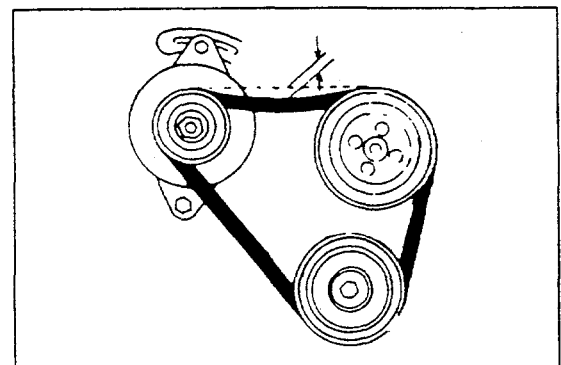

Fig. 3-37

WM-03058

6. Checking valve clearances

(1) Warm up the engine.

Cooling water temperature: 75 - 85°C (167 - 185°F)

(2) Check the valve clearances.

Specified Valve Clearance:

Intake valve:

0.27 ± 0.05 mm (0.0106 ± 0.002 inch)

Exhaust valve:

0.32 ± 0.05 mm (0.0126 ± 0.002 inch)

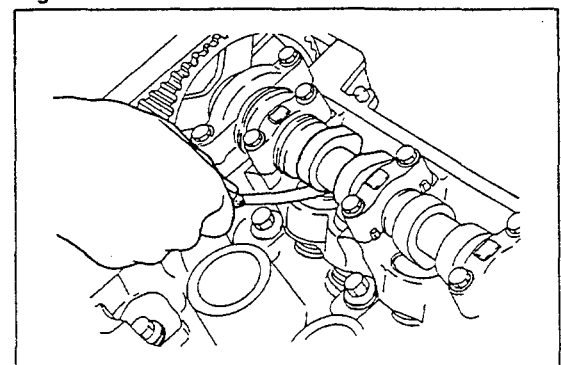

Fig. 3-38

WM-03059

Carry out the checking of valve clearances, with the piston of the No.1 cylinder set to the end of the compression stroke or to the tops of the intake and exhaust strokes, respectively. See the table at the right for the adjustable valves for the respective positions of the No.1 piston.

Crank angle	Cylinder		
	1	2	3
When No.1 piston is set to end of compression stroke	IN	○	○
	EX	○	○
When No.1 piston is set to tops of intake and exhaust strokes, respectively	IN	○	
	EX		○

WM-03060

ENGINE TUNE-UP

(3) If the valve clearances do not conform to the specified values, replace the adjusting shims, following the procedure given below.

- ① Turn the crankshaft so that the cam lobe of the cylinder to be adjusted assumes nearly the upright position of the valve.

NOTE:

When the valve clearances are adjusted, make sure that the piston of the cylinder to be adjusted is not at its top dead center.

(If the SST is used when the piston is at its top dead center, the valves may interfere with the piston, thus damaging the valves and piston.)

- ② Set the cut-out section of each lifter to a position indicated in the figure.
SST: 09248-87703-000

- ③ Insert the SST into between the camshaft and the valve lifter, as shown in the figure.
In this way, push down the two lifters.

- ④ Using a mini-sized nose plier or the like, raise the adjusting shim through the cut-out section of the lifter.

- ⑤ Select a suitable shim.

Thickness of shim to be selected =
Thickness of removed shim + measured valve clearance – specified valve clearance

[Reference]

Adjusting shim is available in 41 different kinds within range from 2.500 to 3.300 mm in increments of 0.02 mm

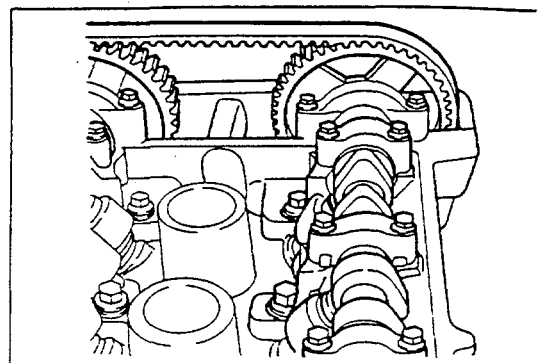

Fig. 3-39

WM-03061

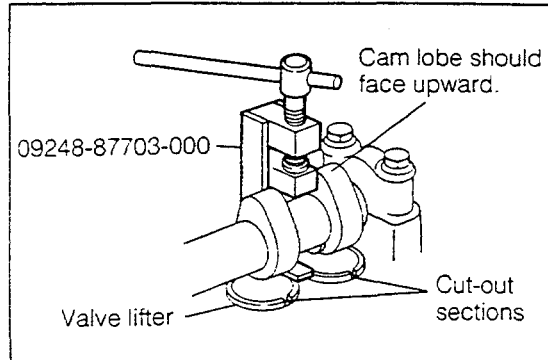

Fig. 3-40

WM-03062

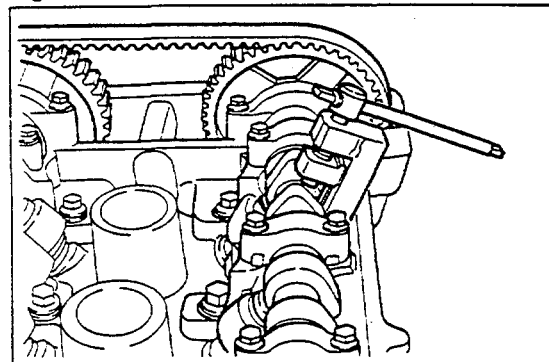

Fig. 3-41

WM-03063

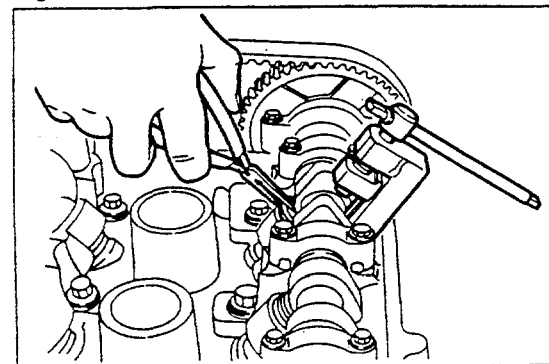

Fig. 3-42

WM-03064

WM-03065

- ⑥ Place the selected shim in the lifter. The shim should be placed in such a direction that the surface marked by inerasable ink faces toward the lifter side.

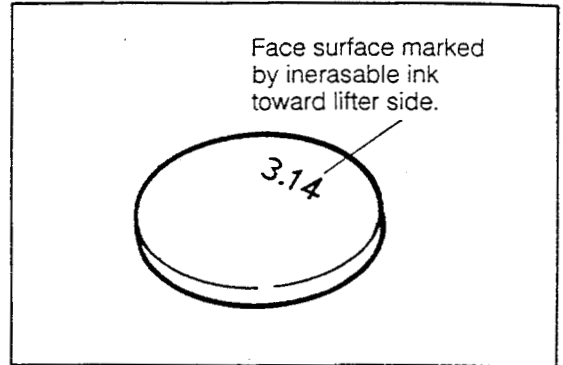

Fig. 3-43

WM-03066

- ⑦ Remove the SST.
- ⑧ Ensure that the valve clearances have been adjusted within the specifications.

NOTE:

See the section under "Checking valve clearances."

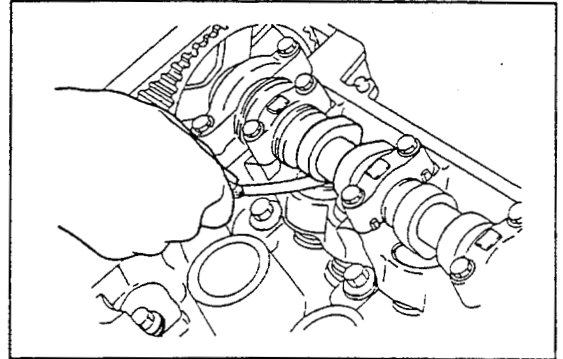

Fig. 3-44

WM-03067

- ⑨ Install the cylinder head cover.

WM-03068

7. Checking ignition timing

- (1) Warm up the engine.
- (2) Short the terminal T.
Read the outputted diagnosis code. If any abnormality is detected, perform the trouble shooting. (See the "Trouble Shooting for Type CB-80 Engine Control System.")

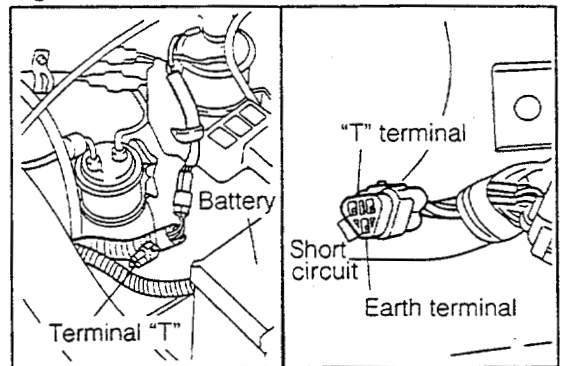

Fig. 3-45

WM-03069

- (3) Adjust the idle speed to 950 ± 50 rpm by means of the idle adjusting screw of the throttle body.

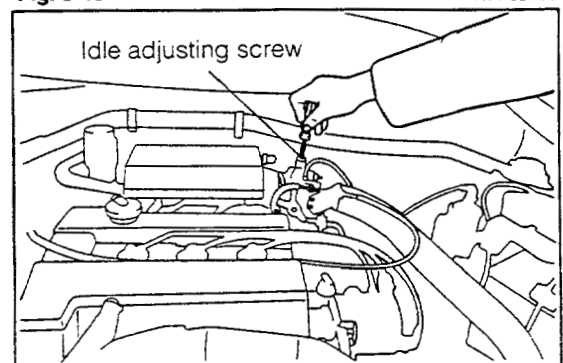

Fig. 3-46

WM-03070

- (4) While the engine is idling, check the ignition timing, using a timing light. Ensure that the ignition timing is correct, using the ignition timing mark on the flywheel and the indicator.

Reference

Ignition timing: $10^\circ \pm 2^\circ$ BTDC/ 950 ± 50 rpm

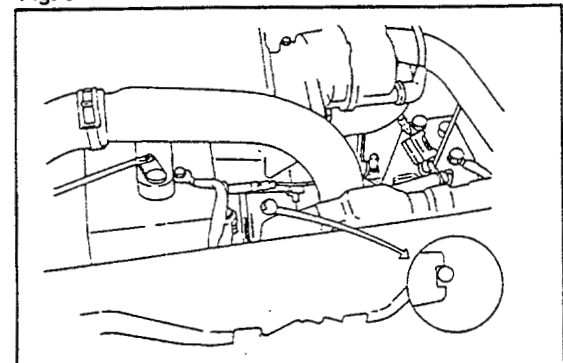

Fig. 3-47

WM-03071

ENGINE TUNE-UP

(5) Adjustment

If the ignition mark fails to align with the indicator, slacken the attaching bolts of the distributor. Adjust the ignition timing by turning the distributor body.

NOTE:

When the distributor body is turned counterclockwise, the ignition timing is advanced. Conversely, when the distributor body is turned clockwise, the ignition timing is retarded.

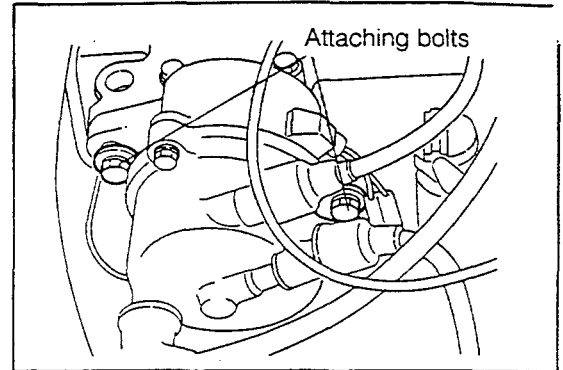

Fig. 3-48

WM-03072

(6) Securely tighten the attaching bolts of the distributor.

NOTE:

Care must be exercised to ensure that the distributor body will not turn during this tightening operation.

Tightening Torque: 1.5 - 2.2 kg-m (11 - 16 ft-lb)

(7) Detach the short pin at the terminal T.

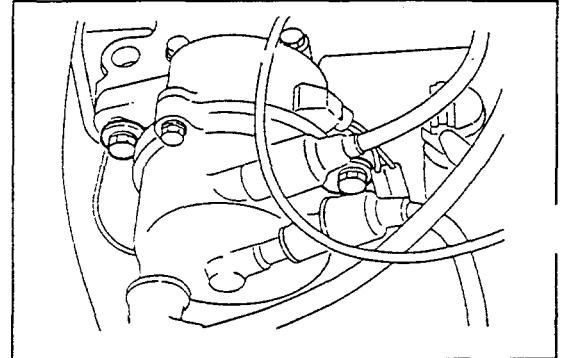

Fig. 3-49

WM-03073

8. Checking idle speed

NOTE:

The following notes must be observed before or during the idle speed adjustment.

- ① Warm up the engine thoroughly. (Warm up the engine for about another 15 minutes after the cooling fan has started its operation.)
- ② Do not perform the engine idle speed adjustment while the fan motor is functioning.
- ③ Never apply extra loads such as the headlamps or the like during the adjustment of the engine idle speed. (As for the day-light-equipped vehicles, disconnect the day-light relay connector.)
- ④ Be sure to install the air cleaner element in place.
- ⑤ Ensure that the exhaust system exhibits no gas leakage.
- ⑥ Ensure that the intake system exhibits no air leakage.

WM-0307

(1) Check and adjustment of idle speed

- ① Install a tachometer and a CO meter.
- ② Turn the bypass screw of the throttle body so that the engine idle speed becomes 950 ± 50 rpm. (When the bypass screw is turned clockwise, the idle speed drops. Conversely, when the bypass screw is turned counterclockwise, the idle speed rises.)

Specified Idle Speed: 950 ± 50 rpm

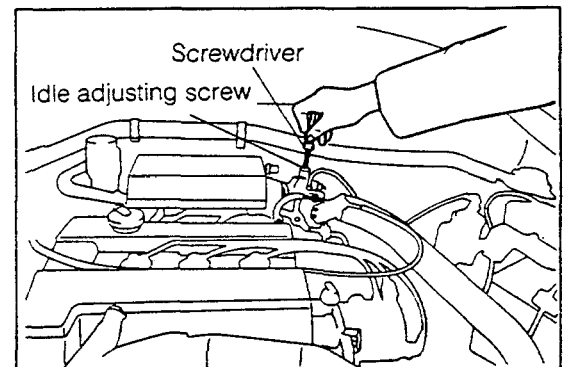

Fig. 3-50

WM-03075

- ③ Measure the CO concentration, as follows:
 Adjust the A/F adjuster screw so that the CO concentration becomes $1 \pm 0.5\%$.
Specified CO Concentration: 0.5 - 1.5 %

After completion of the adjustment, check to see if the engine idle speed conforms to the specifications. If the idle speed fails to conform to the specifications, repeat the operations ② and ③.

NOTE:

Under no circumstances should the adjustment of the A/F adjuster be performed without a CO meter.

(This engine is equipped with the diagnosis function. Therefore, if the A/F adjuster should be adjusted without a CO meter, it may cause an erroneous diagnosis code.)

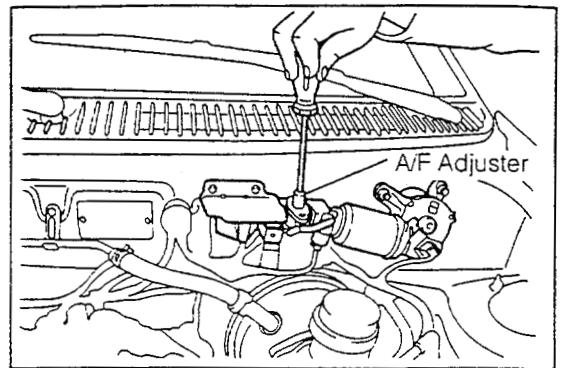

Fig. 3-51

WM-03076

9. Checking dashpot

- (1) Checking of touch revolution speed

- ① Warm up the engine.
- ② Disconnect the vacuum hose from the diaphragm pipe.
- ③ Raise the engine revolution speed to about 2500 rpm. Plug the disconnected diaphragm pipe by your finger.

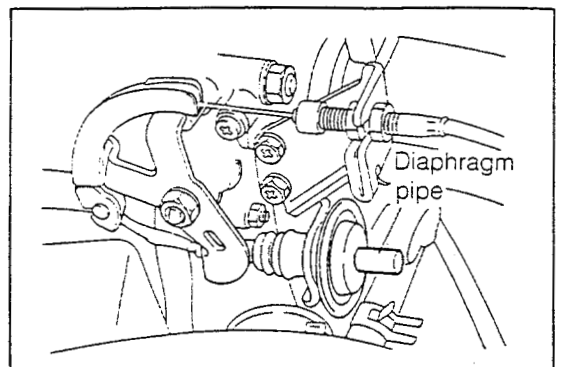

Fig. 3-52

WM-03077

- ④ Release the throttle valve. Measure the engine revolution speed at a time when the throttle touch arm begins to contact the diaphragm shaft.
**Specified Touch Revolution Speed:
 1600 \pm 100 rpm**

If this engine speed drops within the following duration of time, it indicates that the system is functioning properly.

Specified Time: 0.5 - 5 Seconds

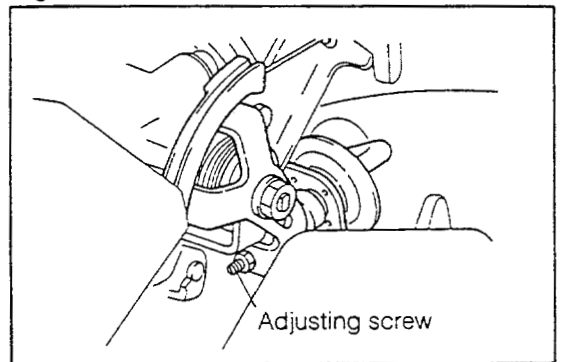

Fig. 3-53

WM-03078

- (2) Adjustment of touch revolution speed

- ① Stop the engine. Slacken the lock nut of the dashpot adjusting screw.
- ② Start the engine.
- ③ Keep the engine revolution speed at about 2500 rpm. Plug the diaphragm pipe of the dashpot by finger.
- ④ Release the throttle valve. Adjust the dashpot adjusting screw so that the touch revolution speed may become the specified value.

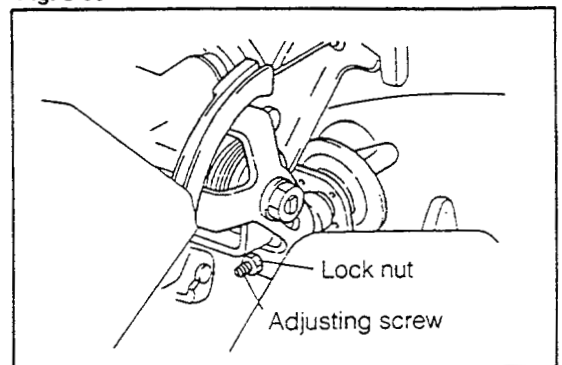

Fig. 3-54

WM-03079

ENGINE TUNE-UP

- ⑤ Stop the engine. Tighten the lock nut of the adjusting screw.
- ⑥ Start the engine. Check the dashpot touch revolution speed.
- ⑦ If the touch revolution speed fails to conform to the specifications, repeat the adjusting procedure above.
- ⑧ Connect the hose.

(3) Dashpot function check

- ① Keep the engine revolution speed at 3000 rpm for a short period of time. Then, release the throttle valve.
- ② Measure the time required for the engine to drop its engine revolution speed from the touch revolution speed to the idle revolution speed.

Specified Time Required: 0.5 - 5.0 seconds

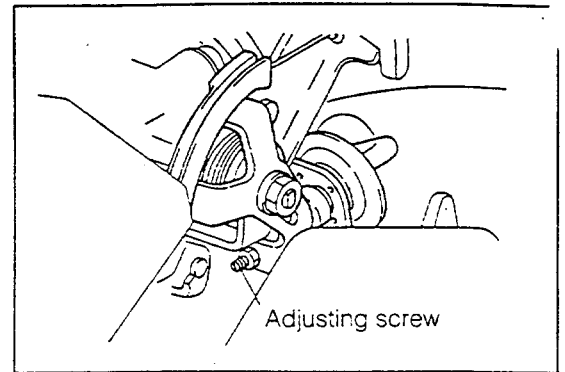

Fig. 3-55

WM-03080

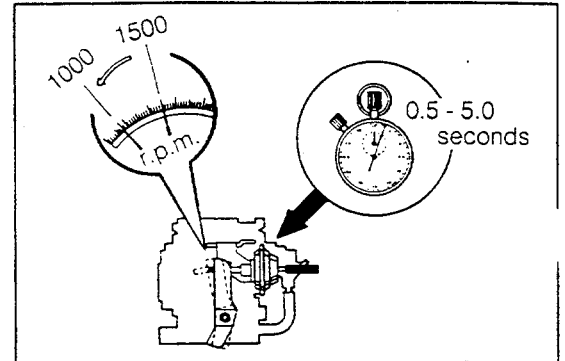

Fig. 3-56

WM-03081

DAIHATSU
TYPE CB
ENGINE

[CB-23, CB-61 & CB-80]

4

SECTION 4
IN-VEHICLE SERVICE

INSTRUCTIONS ON SERVICE OPERATIONS ...	4- 2
TIMING BELT & WATER PUMP	4- 2
CRANKSHAFT OIL SEAL	4- 7
CAMSHAFT [CB-23 & CB-61 ENGINES]	4- 8
CAMSHAFT [CB-80 ENGINE]	4- 9
CAMSHAFT OIL SEAL	
[CB-23 & CB-61 ENGINES]	4-10
CYLINDER HEAD GASKET	
[CB-23 & CB-61 ENGINES]	4-11
CYLINDER HEAD GASKET [CB-80 ENGINE]	4-12
INJECTOR [CB-80 ENGINE]	4-12
OIL PUMP	4-13

WM-04001

INSTRUCTIONS ON SERVICE OPERATIONS

1. This section only describes the removal/installation procedure for those parts which can be removed/installed while the engine is still mounted on the vehicle. As for the overhaul or inspection for the removed parts, see the section under "Engine Overhaul."
2. With regard to those operations for the timing belt, camshaft, crankshaft oil seal, camshaft oil seal and cylinder head gasket, previous to the operations, make sure to set the piston No.1 to the top dead center under the compression stroke.

NOTE:

The top dead center under the compression stroke of the cylinder No.1 can be confirmed by removing the oil filler cap and observing the top mark of the camshaft.

WM-04002

TIMING BELT & WATER PUMP

REMOVAL

1. Drain engine coolant.
2. Remove the air cleaner and hose. (CB-61 & CB-80 engines only)
3. Remove the engine mounting bracket. Prior to this operation, support the oil pan with a jack.

NOTE:

Be very careful not to deform the oil pan.

Extreme care must be exercised not to damage the oil drain plug.

The deformation of the oil pan will cause engine seizure.

4. Remove the V-belt.
5. Remove the water pump pulley.
6. Remove the crankshaft pulley.
When the crankshaft pulley is slackened, lock the ring gear, using a screwdriver or the like.
(On Type CB-80 engine, the space is very limited for this operation. Hence, it is advisable to use a screwdriver whose end is bent at a right angle for this operation.)

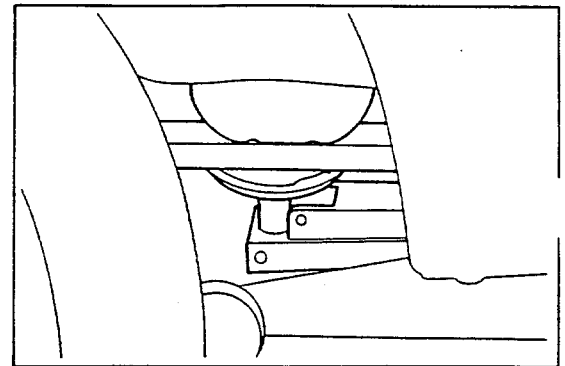

Fig. 4-1

WM-04003

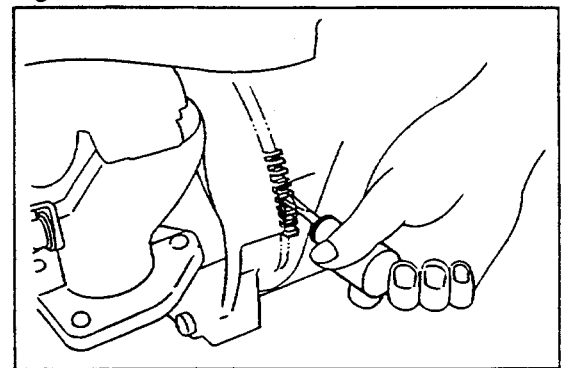

Fig. 4-2

WM-04004

7. Remove the bracket (surge tank & cylinder head cover). (CB-80 engine only)
8. Remove the resistive cords. (CB-80 engine only)
9. Remove the cylinder head cover. (CB-80 engine only)
10. Remove the timing belt upper cover.
11. Remove the timing belt lower cover.
12. Remove the timing belt tensioner.

Before the timing belt tensioner is removed, align the punch marks of the crankshaft and camshaft timing belt pulleys with the indicator marks, respectively, thus setting the piston No.1 to the top dead center under the compression stroke.

(CB-23 & CB-61 engines)

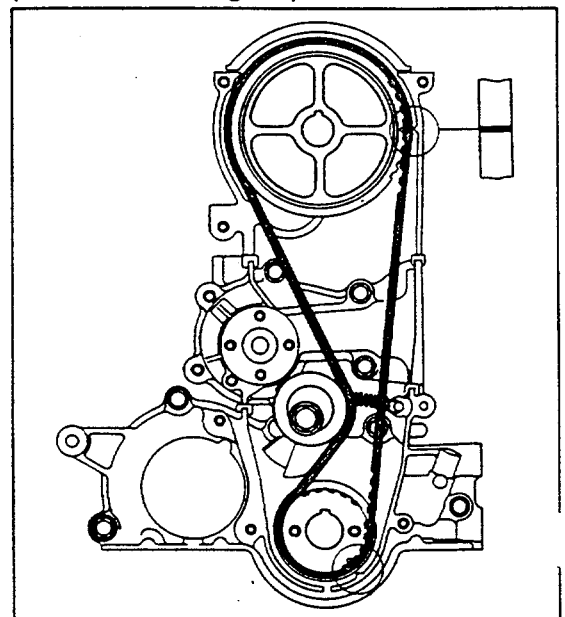

Fig. 4-3

WM-04005

13. Remove the crankshaft timing belt pulley flange.
 14. Remove the timing belt.
- Prior to the timing belt removal, put a mark which shows the normal rotating direction at the back surface of the timing belt, using chalk or the like.

NOTE:

- ① When removing the timing belt, never use a tool such as a screwdriver.
- ② Make sure not to bend the belt sharply to form a small radius. Such practice will cut the belt cord.
- ③ Never permit oils or water to get to the belt, for such matter would shorten the life of the belt.

15. Remove the water pump.

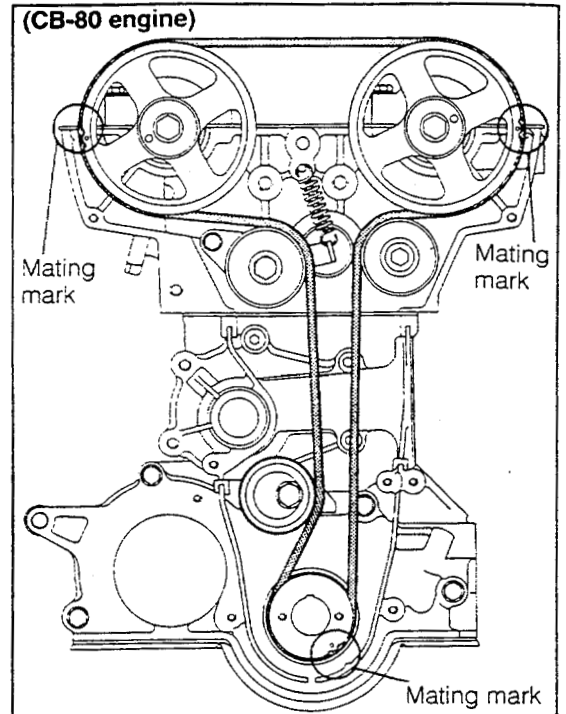

Fig. 4-4

WM-04006

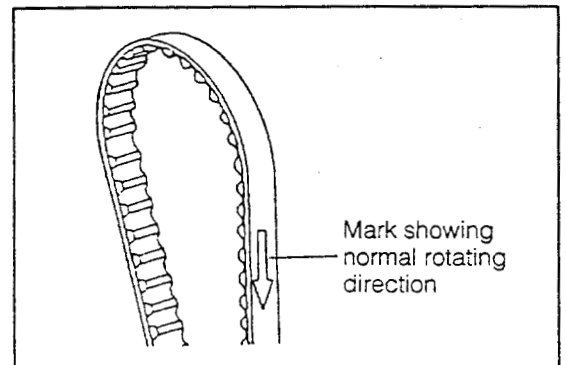

Fig. 4-5

WM-04007

WM-04008

INSTALLATION

1. Install the water pump.

NOTE:

Be sure to replace the gasket with a new one.

2. Installation of timing belt tensioner
 - (1) With the timing belt tensioner set to the lowest position, temporarily tighten the attaching bolt (two attaching bolts in case of CB-80 engine) of the timing belt tensioner.
(This tightening must be made to such an extent that the tensioner can not be moved when the tension spring is attached.)

(CB-23 & CB-61 engines)

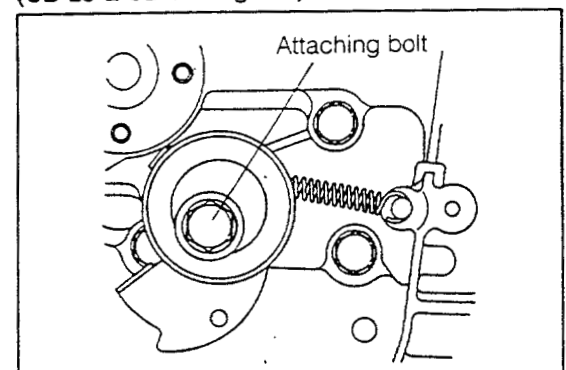

Fig. 4-6

WM-04009

IN-VEHICLE SERVICE

- (2) Install the tension spring. Ensure that the tension spring are positively hooked at its both ends and will not be detached.

(CB-80 engine)

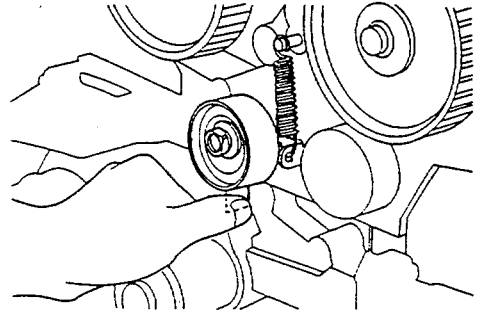

Fig. 4-7

WM-04010

3. Install the timing belt.

NOTE:

- ① Make sure not to bend the belt sharply to form a small radius. Such practice will cut the belt cord.
- ② Never permit oils or water to get to the belt, for such matter would shorten the life of the belt.
- ③ When installing the belt, never try to pry the belt with a screwdriver or the like.
- ④ When turning the engine with the belt installed, the rotation should be made at the crankshaft side.
- ⑤ If the belt is reused, install the belt in such a way that the belt is turned in the same direction as indicated by the arrow mark which was put at the belt's back surface during the belt removal.

(CB-80 engine)

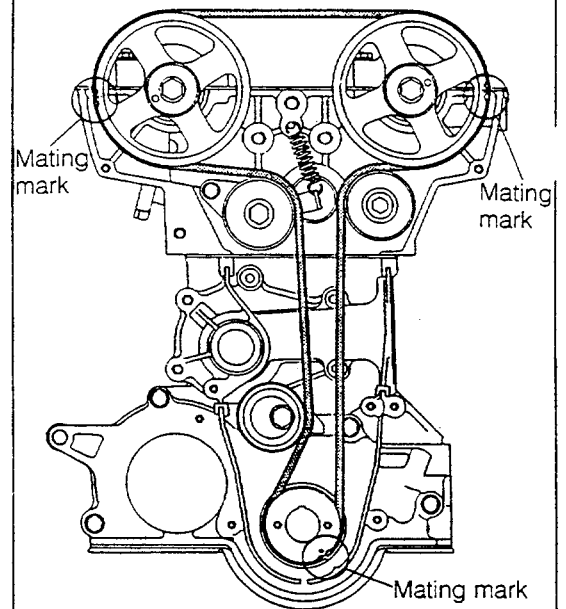

Fig. 4-8

WM-04011

- (1) Ensure that the mating marks of the crankshaft and camshaft timing belt pulleys are aligned with the indicator marks, respectively.

(CB-23 & CB-61 engines)

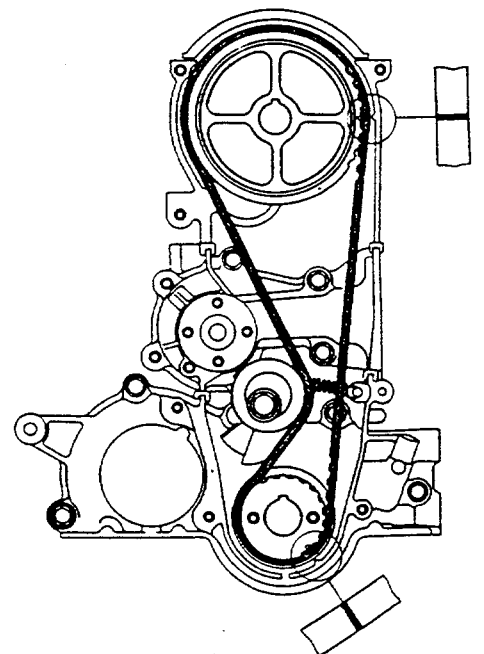

Fig. 4-9

WM-04012

(CB-80 Engine only)

- (2) Install the timing belt in such a way that the part number of the timing belt can be seen properly, as viewed toward the cylinder head side, and comes between the timing marks of the camshaft pulley. Also, make sure that the three mating marks at the back surface of the belt are aligned with the mating marks on the camshaft and crankshaft timing belt pulleys, respectively. Ensure that the belt is not slackened, especially at the tension side (exhaust side) of the belt.

NOTE:

If the three mating marks at the back surface of the belt are erased, the belt should be installed in such a way that the belt is not slackened at the tension side (exhaust side).

- (3) Ensure that the mating marks of the timing belt pulleys are aligned with the mating marks on the belt, respectively.
- (4) Slacken the attaching bolts of the tensioner which were tightened temporarily in the previous step. Ensure that the timing belt tension is provided by the tension spring.

- (5) Turn the crankshaft slightly in the normal rotating direction (clockwise), thus applying tension to the timing belt between the intake camshaft timing belt pulley and the exhaust camshaft timing belt pulley and between the exhaust camshaft timing belt pulley and the crankshaft timing belt pulley.

- (6) Tighten the timing belt tensioner temporarily.

- (7) Turn the crankshaft about two turns in the normal rotating direction, until the mating mark on the cylinder head is aligned with the recessed timing mark on the camshaft.

NOTE:

Never make a reverse turn, even if it is the slightest one, during this operation.

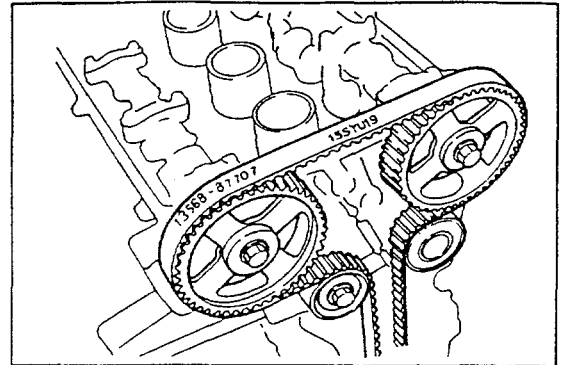

Fig. 4-10

WM-04013

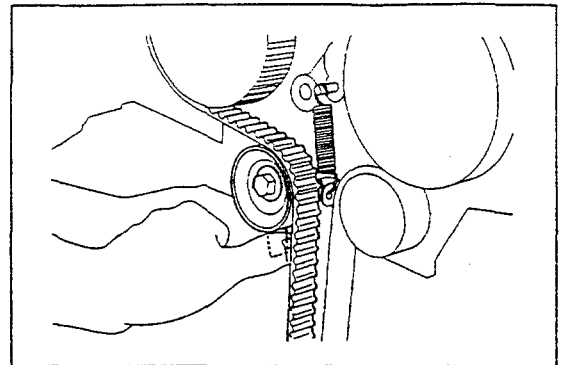

Fig. 4-11

WM-04014

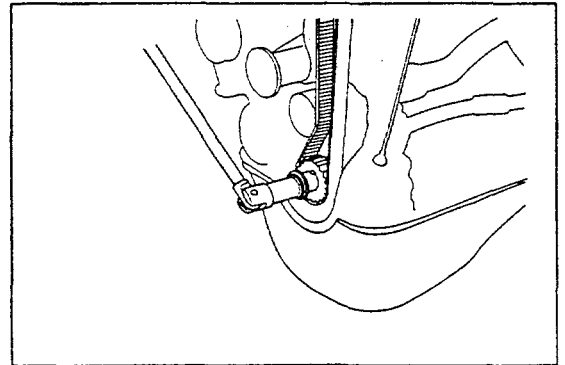

Fig. 4-12

WM-04015

WM-04016

IN-VEHICLE SERVICE

- (8) Ensure that the tension spring force is being applied to the tensioner, by slackening the bolts of the timing belt tensioner.

WM-04017

- (9) Tighten the bolts of the timing belt tensioner.

Tightening Torque:

(CB-23 & CB-61 engines)

1.9 - 3.1 kg-m (14 - 22 ft-lb)

(CB-80 engine)

M10 bolt 3.0 - 4.5 kg-m (22 - 33 ft-lb)

M6 bolt 0.6 - 0.9 kg-m (5 - 7 ft-lb)

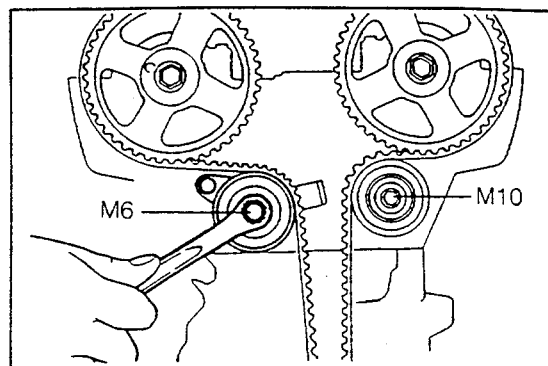

Fig. 4-13

WM-04018

- (10) Align the ignition timing marks at the flywheel by turning the crankshaft one turn.

Push the belt between the camshaft timing belt pulleys with a force of 3 kg (6.6 lb). Check to see if the deflection meets the specification.

Specified Deflection: About 5 mm (0.197 inch)

(with a force of 3 kg (6.6 lb) applied)

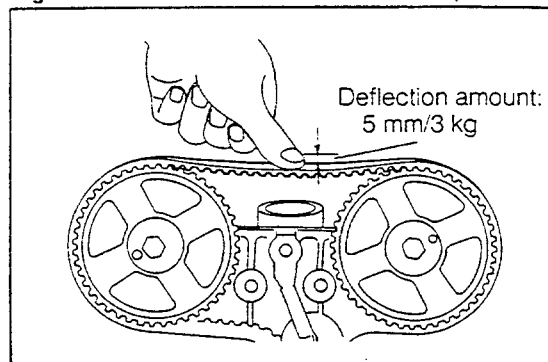

Fig. 4-14

WM-04018A

4. Install the crankshaft timing belt pulley flange.

NOTE:

Be sure to install the crankshaft timing belt pulley flange in the correct direction.

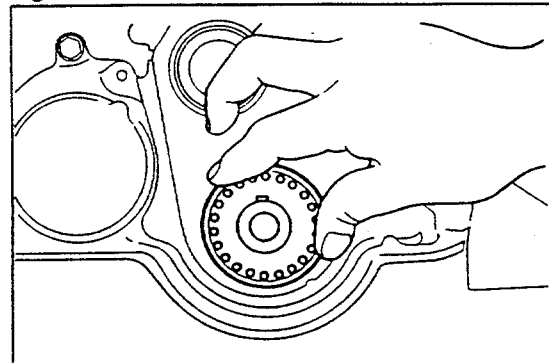

Fig. 4-15

WM-04L

5. Install the cylinder head cover. (CB-23 & CB-61 engines)
6. Install the resistive cords. (CB-23 & CB-61 engines)
7. Install the air cleaner assembly. (CB-23 engine only)
8. Install the intake pipe. (CB-61 engine only)
9. Install the surge tank. (CB-61 engine only)
10. Install the timing belt lower cover.
11. Install the timing belt upper cover.

WM-04020

12. Install the crankshaft pulley.

When the crankshaft pulley is tightened, lock the ring gear, using a screwdriver or the like.

(On Type CB-80 engine, the space is very limited for this operation. Hence, it is advisable to use a screwdriver whose end is bent at a right angle for this operation.)

Tightening Torque: 9.0 - 10.0 kg-m (65 - 72 ft-lb)

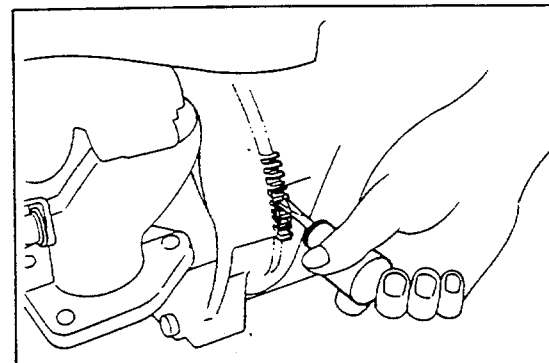

Fig. 4-16

WM-04021

- Install the cylinder head cover. (CB-80 engine only)
14. Install the bracket (surge tank & cylinder head cover). (CB-80 engine only)
 15. Install the water pump pulley.
 16. Install the V-belt.
 17. Install the engine mounting bracket. Remove the jack supporting the oil pan.
 18. Install the air cleaner and hose. (CB-61 & CB-80 engines only)
 19. Fill cooling water.

WM-04022

CRANKSHAFT OIL SEAL

REMOVAL

1. After the operations up to the timing belt removal in the section under "Removal of Timing Belt & Water Pump" have been completed, proceed to this operation of "Crankshaft Oil Seal Removal."
2. Remove the crankshaft timing belt pulley.

NOTE:

If any difficulty should be encountered in removing the crankshaft timing belt pulley, screw-in bolts into the threaded holes provided in the side of the pulley.

3. Remove the crankshaft timing belt pulley flange.
 4. Remove the woodruff key.
 5. Removal of crankshaft oil seal
- Remove the oil seal, using the following SST.

SST: 09223-87702-000

- (1) With the oil seal remover & replacer ① placed against the oil seal, drive a drift into the oil seal so as to make a hole.
- (2) Thread a tapping screw into the thus-produced hole in the oil seal.
- (3) Screw the puller ④ so as to remove the oil seal.

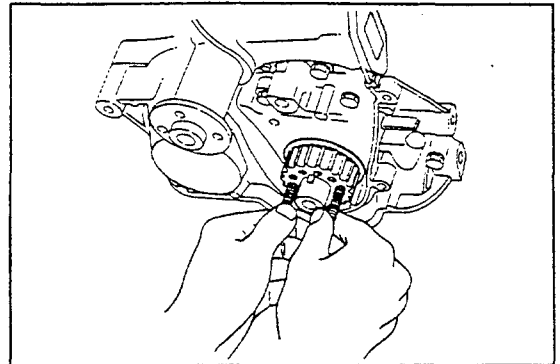

Fig. 4-17

WM-04023

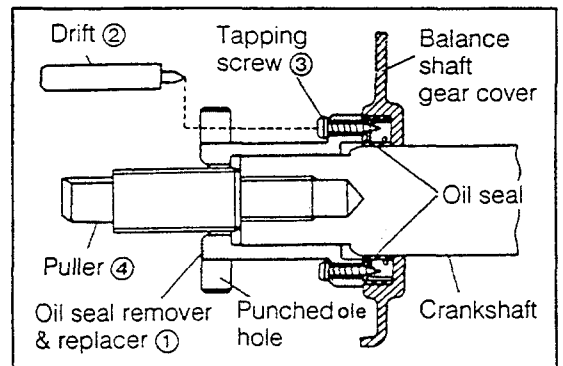

Fig. 4-18

WM-04024

INSTALLATION

1. Install the new crankshaft oil seal.
- SST: 09223-87702-000

- (1) Apply engine oil to the lip section of the oil seal.
- (2) Place the oil seal remover & replacer ① against the oil seal.
- (3) Place the crankshaft attaching bolt (2) against the remover & replacer ①. Then, proceed to install the oil seal into position by turning the crankshaft attaching bolt ②.

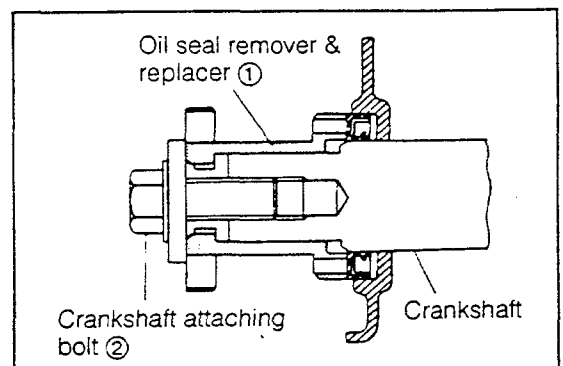

Fig. 4-19

WM-04025

IN-VEHICLE SERVICE

2. Install the woodruff key.
3. Install the crankshaft timing belt pulley flange.

NOTE:

Ensure that the flanges are installed only in the correct direction.

4. Perform the timing belt tensioner installation and the following operations described in the section under "Installation of Timing Belt & Water Pump." As for the contents of these operations, see the section under "Timing Belt & Water Pump."

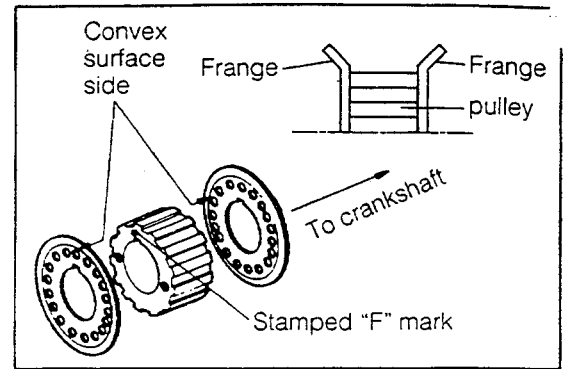

CAMSHAFT (CB-23 & CB-61 Engines)

REMOVAL

1. After the operations up to the timing belt removal in the section under "Removal of Timing Belt & Water Pump" have been completed, proceed to this operation of "Camshaft Removal."
2. Remove the surge tank. (CB-61 engine only)
3. Remove the intake pipe. (CB-61 engine only)
4. Remove the air cleaner assembly. (CB-23 engine only)
5. Remove the resistive cords.
6. Remove the cylinder head cover.
7. Remove the distributor and distributor housing.
8. Remove the camshaft timing belt pulley.

NOTE:

During the timing belt pulley removal, the rotation of the camshaft can be prevented by inserting a screwdriver through the opening of the pulley.

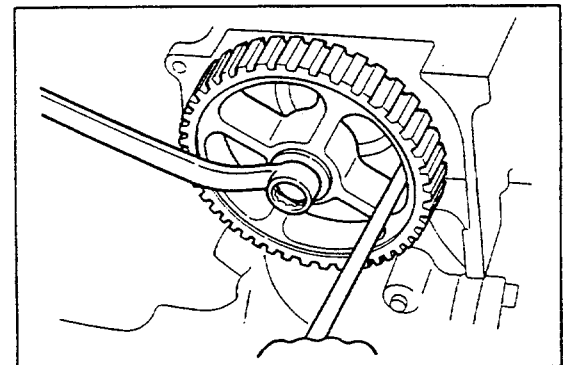

9. Slacken the attaching screws of the valve rocker arm.
10. Remove the camshaft.

INSTALLATION

Reverse the removal procedure to install the camshaft.

WM-04028

AMSHAFT (CB-80 Engine)

REMOVAL

1. After the operations up to the timing belt removal in the section under "Removal of Timing Belt & Water Pump" have been completed, proceed to this operation of "Camshaft Removal."
2. Remove the camshaft timing belt pulley.
NOTE:
The rotation of the camshaft can be prevented by securing the hexagon section on the cylinder No.1.
Do not remove the camshaft timing belt pulley by utilizing the tension of the timing belt.
3. Remove the distributor.
4. Remove the camshaft bearing caps.
5. Remove oil seal from camshaft.
6. Remove the camshafts.

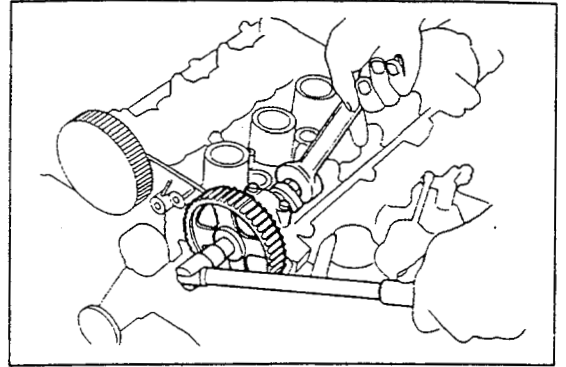

Fig. 4-22

WM-04029

INSTALLATION

1. Install the camshafts.
2. Installation of camshaft bearing caps
Install each camshaft bearing cap as indicated in the right figure, according to the embossed number and arrow at the back side of the camshaft bearing cap.
Tightening Torque: 1.15 - 1.45 kg-m (8.3 - 10.5 ft-lb)

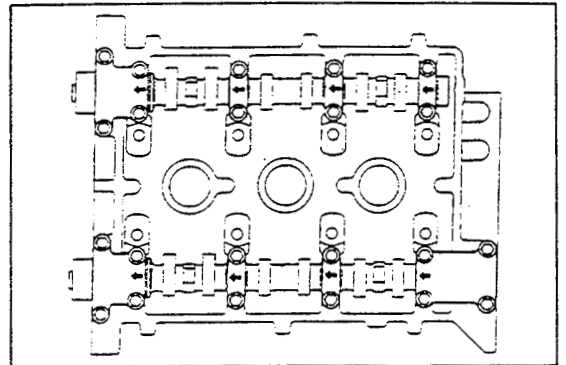

Fig. 4-23

WM-04030

3. Install the new camshaft oil seal, using SST.
SST: 09618-87301-000

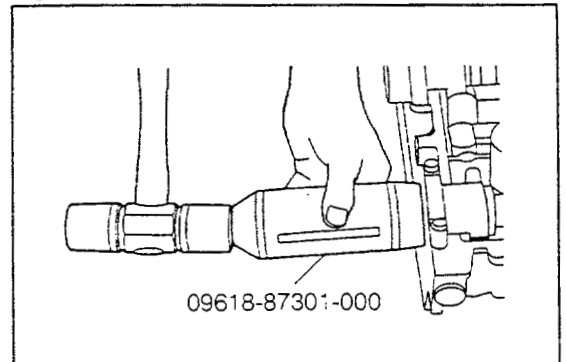

Fig. 4-24

WM-04030A

4. Installation of distributor
 - (1) Remove the distributor cap. Tilt the rotor, as indicated in the right figure.
 - (2) While turning the rotor, push and install the distributor into the groove provided in the camshaft to drive the distributor.

NOTE:

Since the distributor is eccentric with the groove provided in the camshaft, the installation can be performed in one direction. Therefore, never install the distributor forcibly. Failure to observe this note will lead to distributor damage.

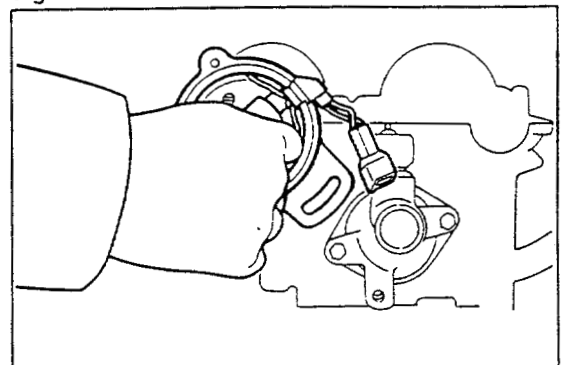

Fig. 4-25

WM-04031

IN-VEHICLE SERVICE

5. Install the camshaft timing belt pulley.

NOTE:

The rotation of the camshaft can be prevented by securing the hexagon section on the cylinder No.1.

Tightening Torque: 3.0 - 4.5 kg-m (22 - 33 ft-lb)

6. Perform the timing belt installation and the following operations described in the section under "Installation of Timing Belt & Water Pump." As for the contents of these operations, see the section under "Timing Belt & Water Pump."

CAMSHAFT OIL SEAL (CB-23 & CB-61 Engines)

REMOVAL

1. After the operations up to the cylinder head cover removal in the section under "Removal of timing belt & water pump" have been completed, proceed to this operation of "Camshaft Oil Seal Removal."

2. Remove the camshaft timing belt pulley.

NOTE:

During the timing belt pulley removal, the rotation of the camshaft can be prevented by inserting a screwdriver through the opening of the pulley.

3. Removal of camshaft oil seal

(1) Make a hole on the oil seal, using the following SST.

SST: 09223-87702-000

(2) Screw in the SST into the hole.

SST: 09223-87702-000

(3) Pry off the oil seal with a screwdriver or the like.

NOTE:

Be careful not to damage the camshaft and cylinder head.

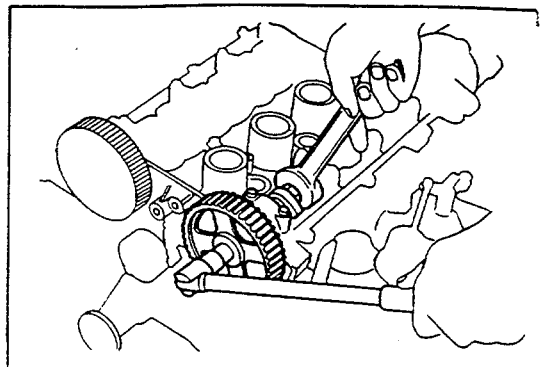

Fig. 4-26

WM-04032

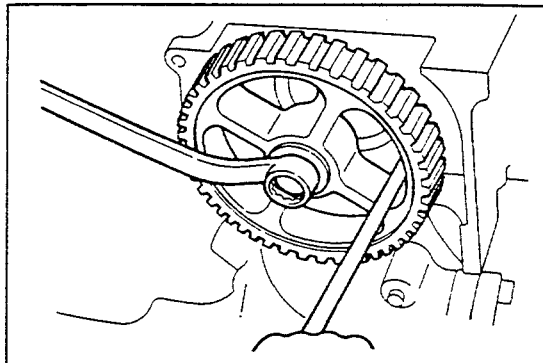

Fig. 4-27

WM-04033

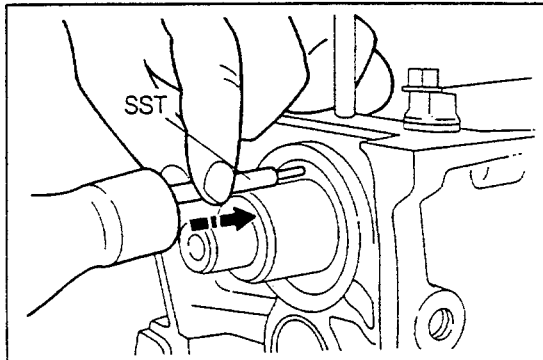

Fig. 4-28

WM-04034

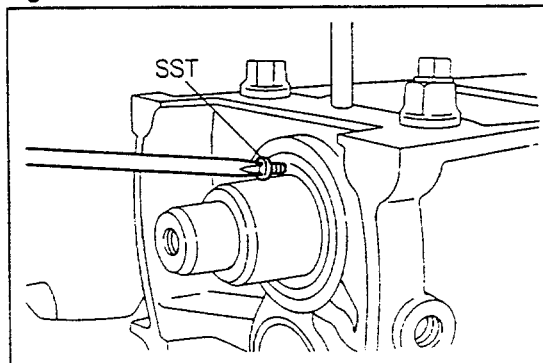

Fig. 4-29

WM-04035

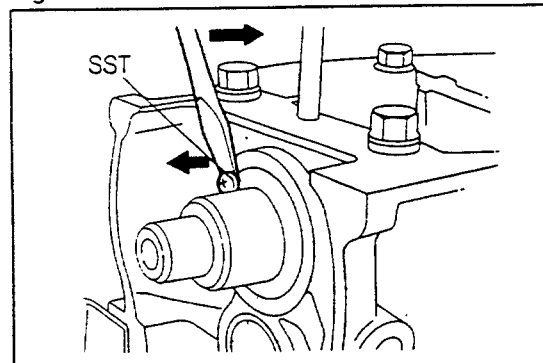

Fig. 4-30

WM-04036

STALLATION

1. Installation of camshaft oil seal
With the SST placed against the oil seal, drive the oil seal into position.

SST: 09608-12010-000

NOTE:

Be sure to use a new oil seal.

2. Install the camshaft timing pulley.
Tightening Torque: 3.0 - 4.5 kg-m (22 - 33 ft-lb)

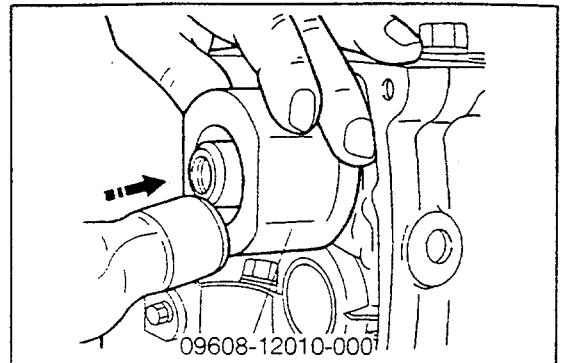

Fig. 4-31

WM-04037

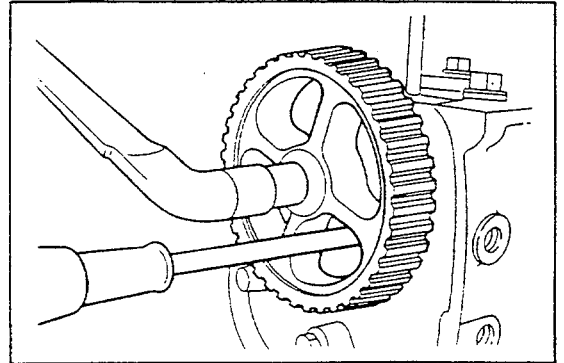

Fig. 4-32

WM-04038

3. Perform the timing belt tensioner installation and the following operations described in the section under "Installation of Timing Belt & Water Pump." As for the contents of these operations, see the section under "Timing Belt & Water Pump."

WM-04039

CYLINDER HEAD GASKET (CB-23 & CB-61 Engines)

REMOVAL

1. After the operations up to the cylinder head cover removal in the section under "Camshaft Removal" have been completed, proceed to this operation of "Cylinder Head Gasket Removal."
2. Drain engine oil

WM-04045

3. Disconnect the exhaust pipe.
4. Remove the EGR pipe. (Specific area only)
5. Disconnect the hoses.
6. Remove the cylinder head assembly.
7. Remove the cylinder head gasket.

INSTALLATION

Reverse the removal procedure to install the cylinder head gasket.

NOTE:

Be sure to use a new gasket oil seal.

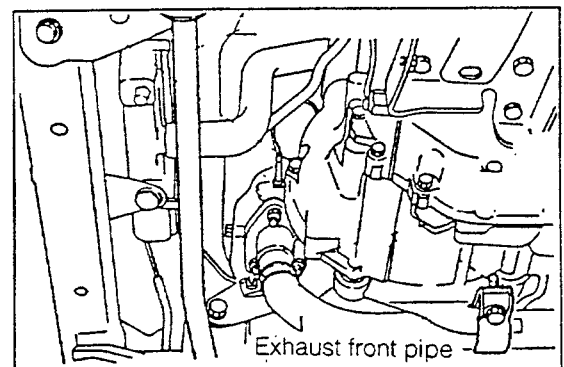

Fig. 4-33

WM-04046

IN-VEHICLE SERVICE

CYLINDER HEAD GASKET (CB-80 Engine)

REMOVAL

1. After the operations up to the distributor removal in the section under "Camshaft Removal" have been completed, proceed to this operation of "Cylinder Head Gasket Removal."
2. Remove the surge tank cover.
3. Remove the hoses.
4. Remove the connectors.
5. Remove the surge tank stay.
6. Disconnect the exhaust pipe.
7. Remove the intake pipe.
8. Remove the cylinder head assembly.
9. Remove the cylinder head gasket.

INSTALLATION

Reverse the removal procedure to install the cylinder head gasket.

WM-04047

INJECTOR (CB-80 Engine)

REMOVAL

1. Remove the surge tank cover.
2. Remove the bracket (surge tank ⊗ cylinder head cover).
3. Remove the intake pipe.
4. Remove the hoses.

Union (for cold start injector)

The fuel line system is retained under a highly-pressurized state. When the union is removed, place a cloth underneath. Be sure to slowly remove the union so as to prevent the fuel from splashing.

5. Remove the connectors
6. Remove the surge tank.
7. Remove the delivery pipe.
8. Remove the insulator.
9. Remove the injector.

INSTALLATION

Reverse the removal procedure to install the injector.

NOTE:

Be sure to use new gaskets.

WM-04049

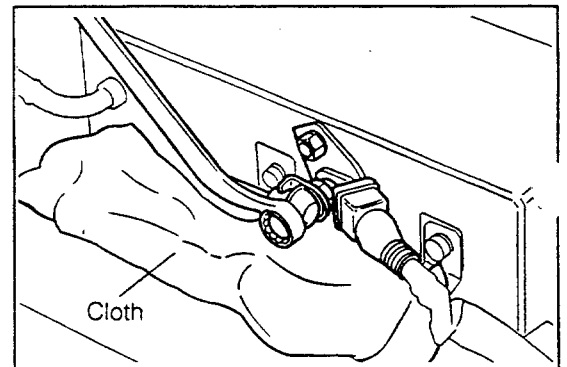

Fig. 4-34

WM-04048

OIL PUMP

REMOVAL

1. Remove the exhaust pipe.
2. Remove the bracket (transmission ⊗ exhaust pipe).
3. Remove the engine mounting rear bracket No.2.
4. Remove the engine mounting rear bracket No.1.
5. Remove the engine lower mounting member.
6. Remove the stiffener plate.
7. Remove the oil pan.
8. Remove the oil pan gasket.
9. Remove the oil pump drive shaft sprocket.
10. Remove the oil jet. (CB-80 engine only)
11. Remove the oil pump.

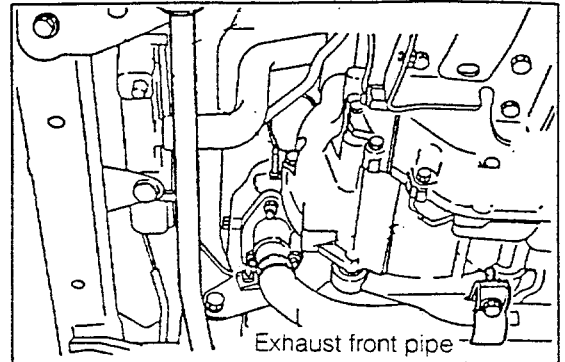

Fig. 4-35

WM-04050

INSTALLATION

1. Install the oil pump.

NOTE:

Be sure to use new "O" ring

2. Install the oil jet. (CB-80 engine only)
3. Install the oil pump drive shaft sprocket.

NOTE:

Be sure to install the oil pump drive shaft sprocket with the side having the "CB OUTSIDE" stamp facing to the outside.

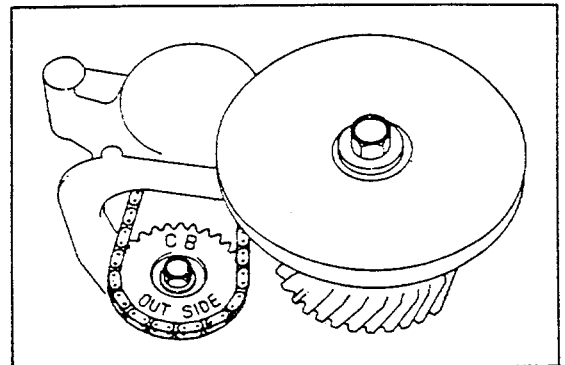

Fig. 4-36

WM-04051

4. Install the oil pan gasket.

- ① Apply the sealer to the cylinder block, following the procedure indicated in the illustration at the right.

Sealer to be used: Silicon Bond

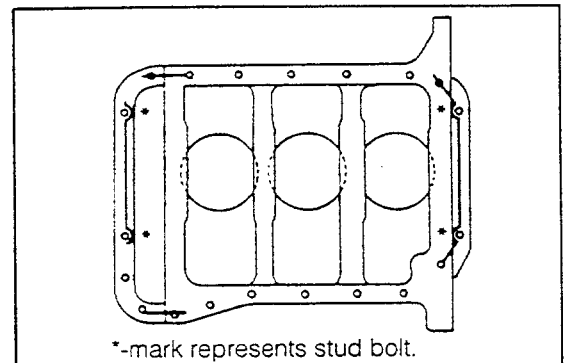

Fig. 4-37

WM-04052

- ② Apply the sealer to the oil pan gasket a the oil pan side, following the procedure indicated in the illustration at the right. Place the oil pan gasket on the cylinder block.

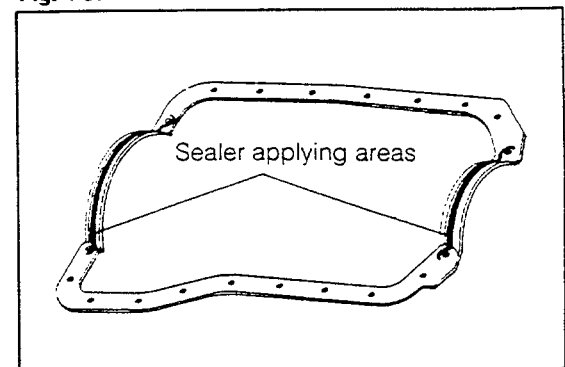

Fig. 4-38

WM-04053

IN-VEHICLE SERVICE

5. Install the oil pan.
Tighten the stud bolt sections temporarily. Then, tighten the oil pan attaching bolts in the sequence as shown in the illustration at the right.

Tightening Torque: 0.4 - 0.7 Kg-m (2.9 - 5.1 ft-lb)

The numerals in () in the illustration at the right denote the temporal tightening sequence for the stud bolts.

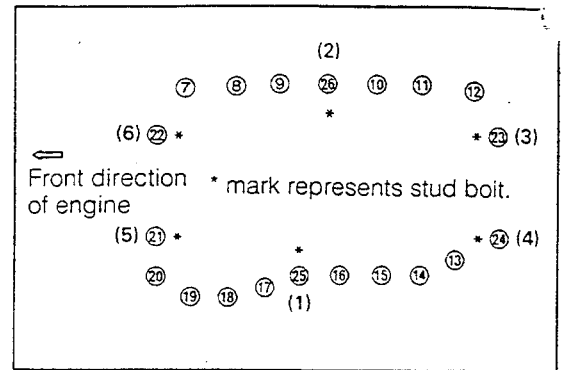

Fig. 4-39

WM-04054

6. Install the stiffener plate.
7. Install the engine lower mounting member.
8. Install the engine mounting rear bracket No.1.
9. Install the engine mounting rear bracket No.2.
10. Install the bracket (transmission ⊗ exhaust pipe).
11. Install the exhaust pipe.

WM-04055

DAIHATSU
TYPE CB
ENGINE

[CB-23, CB-61 & CB-80]

E

SECTION 5

ENGINE MECHANICALS

REMOVAL AND INSTALLATION OF ENGINE ...	5- 2
INTAKE AND EXHAUST SYSTEM	5-14
CB-23 AND CB-61 ENGINES	5-14
CB-80 ENGINE	5-19
TIMING BELT	5-24
CB-23 AND CB-61 ENGINES	5-24
CB-80 ENGINE	5-30
CYLINDER HEAD	5-39
CB-23 AND CB-61 ENGINES	5-39
CB-80 ENGINE	5-55
CYLINDER BLOCK	5-69

WM-05001

ENGINE MECHANICALS

REMOVAL AND INSTALLATION OF ENGINE

REMOVAL

1. Drain the engine oil and cooling water.

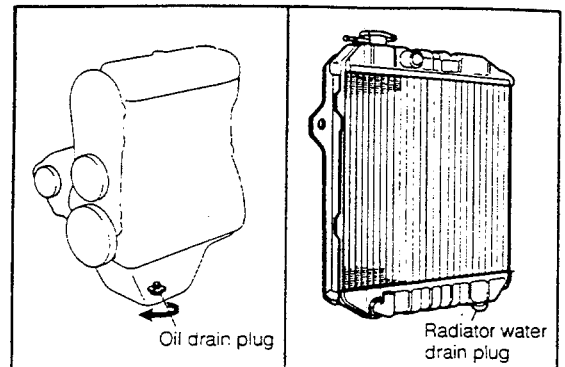

Fig. 5-1

WM-05002

2. Remove the engine hood.

NOTE:

This operation must be performed by at least two persons. Since the engine hood is quite heavy, be very careful not to scratch the body and hood.

WM-05003

3. Disconnect the negative \ominus terminal of the battery. Detach the hold-down clamp and remove the battery.
4. Remove the battery carrier stay.

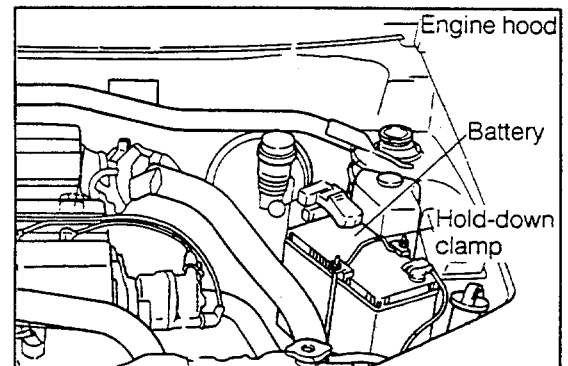

Fig. 5-2

WM-05004

5. Remove the intercooler assembly. (CB-80 engine only)

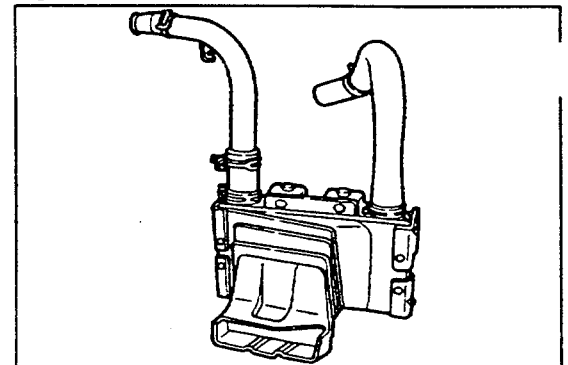

Fig. 5-3

WM-05005

6. Remove the radiator.
7. Remove the air cleaner assembly.
8. Remove the blow-by hose. (CB-61 engine only)

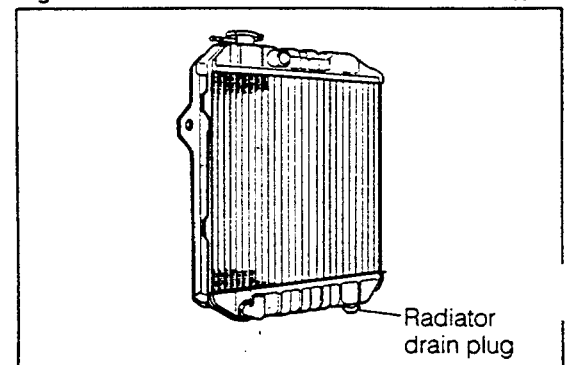

Fig. 5-4

WM-05006

Disconnect the speedometer cable.

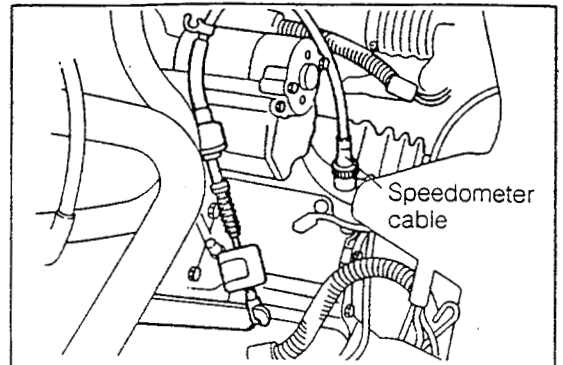

Fig. 5-5

WM-05007

10. Disconnect the clutch cable.

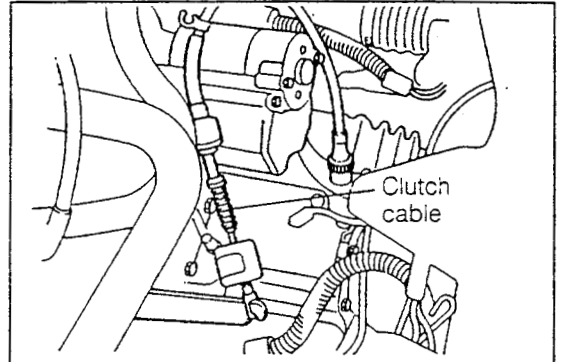

Fig. 5-6

WM-05008

11. Disconnect the accelerator cable assembly.

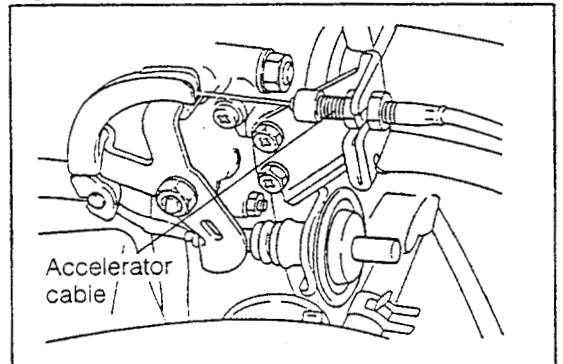

Fig. 5-7

WM-05009

12. Disconnect the brake booster hose.

13. Disconnect the heater hose.

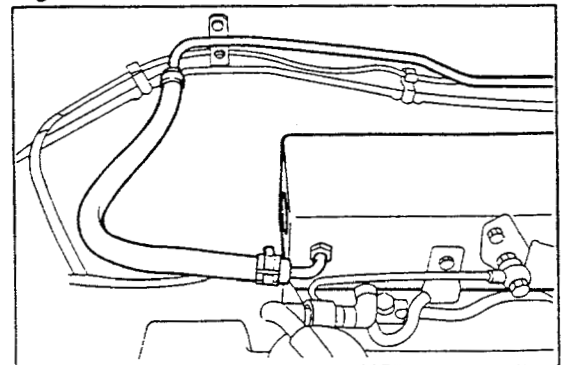

Fig. 5-8

WM-05010

14. Disconnect the hose of the turbocharger waste gate valve.
(CB-80 engine only)

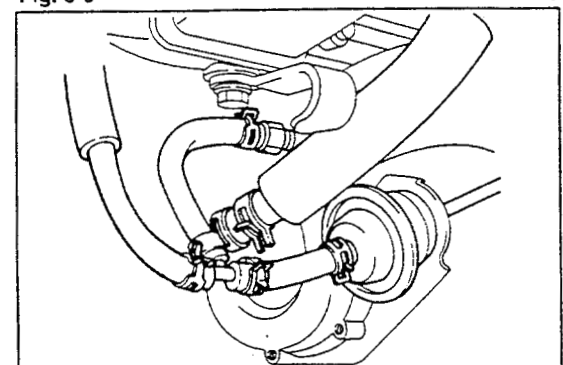

Fig. 5-9

WM-05011

ENGINE MECHANICALS

15. Disconnect the fuel pipe.

- 1) Disconnect the fuel hose between the fuel filter and the delivery pipe. (CB-80 engine only)

SST: 09258-00030-000

NOTE:

Even when the engine is stopped, a fuel pressure of about 2.55 kg/cm² (36.3 psi) is applied to the fuel line. Hence, be sure to prevent the fuel from splashing, using a cloth or the like.

- 2) Disconnect the fuel return hose between the delivery pipe and the fuel tank. (CB-80 engine only)

NOTE:

When disconnecting the hose, be sure to prevent the fuel from splashing, using a cloth.

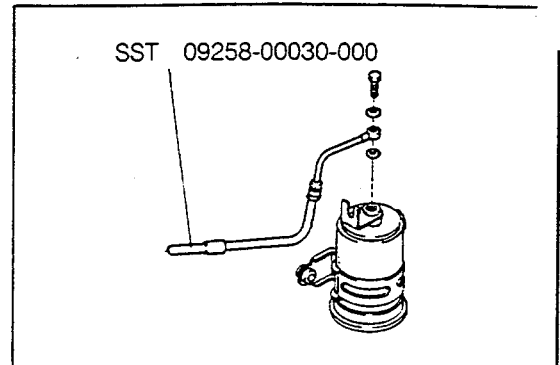

Fig. 5-10

WM-05012

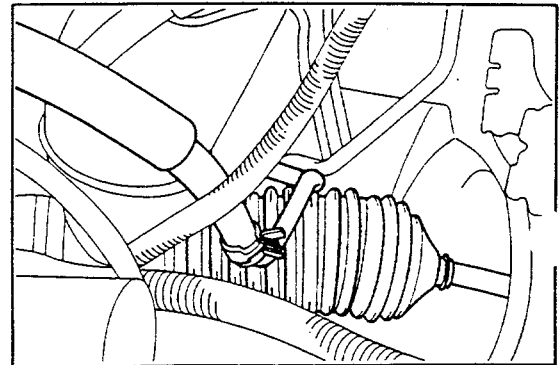

Fig. 5-11

WM-05013

16. Disconnect the wire harness connector.

NOTE:

- ① The following explanation and illustrations for disconnecting the wire harness connector pertains to Type CB-80 engine. For Type CB-23 and CB-61 engines, refer to the following sections before starting the operation.
- ② Care must be exercised as to the removal method of the connector. Some connectors can be removed by pulling the lock section, while others can be removed by pushing the lock section.

[CB-23]

While the engine proper is still mounted on the vehicle, disconnect each connector of the switches and sensors. Make sure that the wire harnesses are left at the vehicle side when the engine proper is removed.

WM-05014

[CB-61]

Disconnect the connector between the cowl wire harness and the engine wire harness, as indicated in the right figure. After the engine has been removed, disconnect each connector of the switches and sensors at the engine proper.

NOTE:

When removing the engine, perform final check to ensure that all connectors have been disconnected.

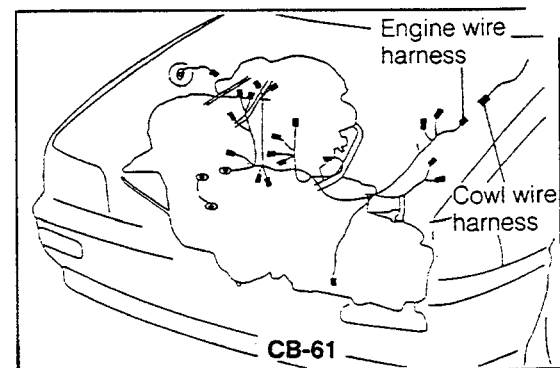

Fig. 5-12

WM-05015

Disconnect the distributor-related harness couplers.

(CB-80 engine only)

- 1) Injector time switch
- 2) Water temperature sensor
- 3) Fan motor switch
- 4) Thermostat sender unit
- 5) Distributor connector
- 6) Ignition coil resistive cord

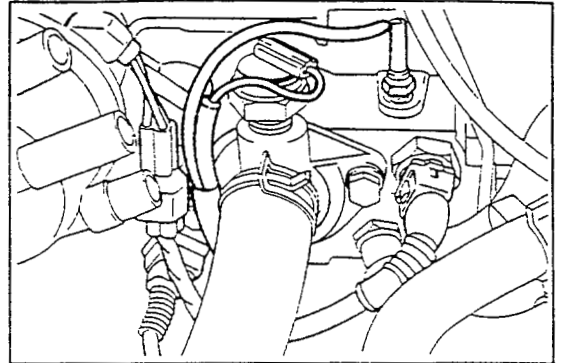

Fig. 5-13

WM-05016

18. Disconnect the surge tank-related harness couplers.

(CB-80 engine only)

- 1) Cold start injector
- 2) Coupler of each injector

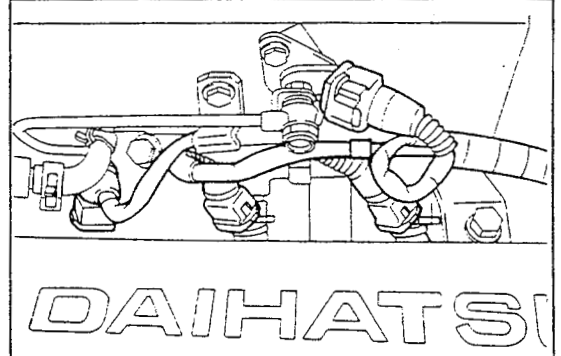

Fig. 5-14

WM-05017

19. Disconnect the transmission-related harness couplers.

(CB-80 engine only)

- 1) Starter harness
- 2) Transmission earth
- 3) Backup lamp harness

20. Remove the surge tank cover. (CB-80 engine only)

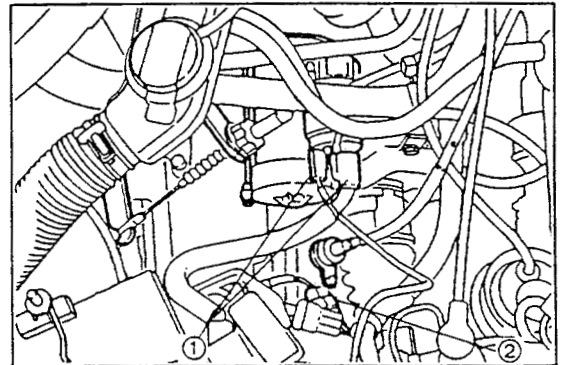

Fig. 5-15

WM-05018

21. Disconnect the engine-related harness couplers. (CB-80 engine only)

- 1) Throttle sensor
- 2) Pressure sensor
- 3) Variable resistor
- 4) Intake air temperature sensor
- 5) Earth
- 6) Oil pressure switch
- 7) Alternator connector

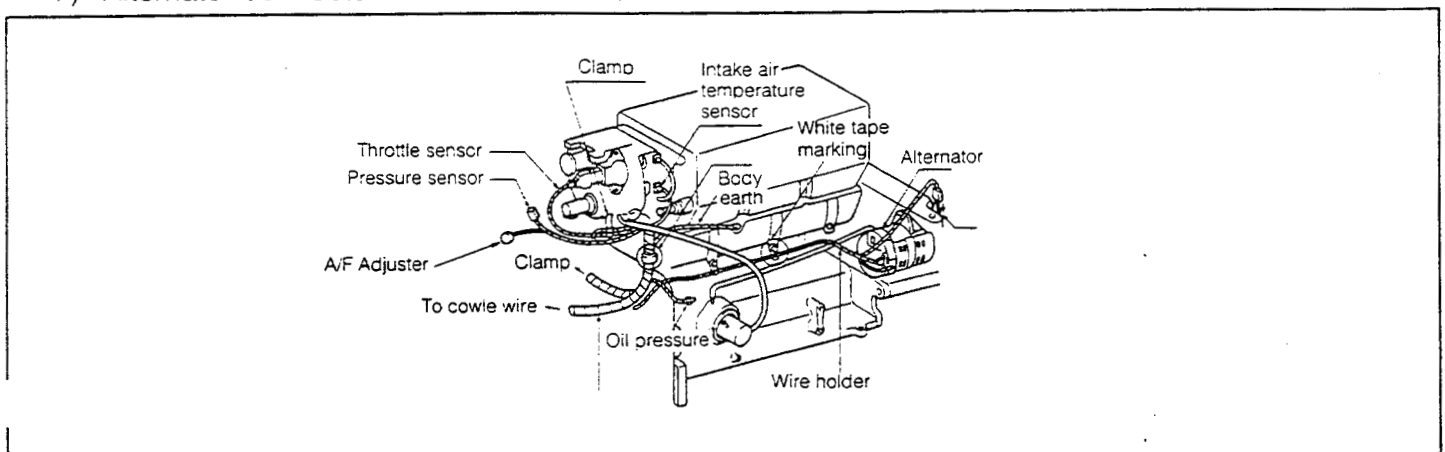

Fig. 5-16

WM-05019

ENGINE MECHANICALS

22. Jack up the vehicle. Support the vehicle with safety stands. Remove the wheels.

NOTE:

For the supporting points, see the section under "GENERAL INFORMATION."

23. Drain the transmission oil.

WM-05020

24. Disconnect the shift & selector shaft subassembly.

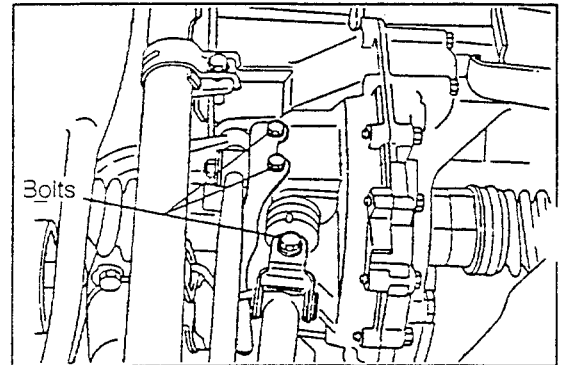

Fig. 5-17

WM-05021

25. Disconnect the exhaust front pipe. Remove it from the manifold.

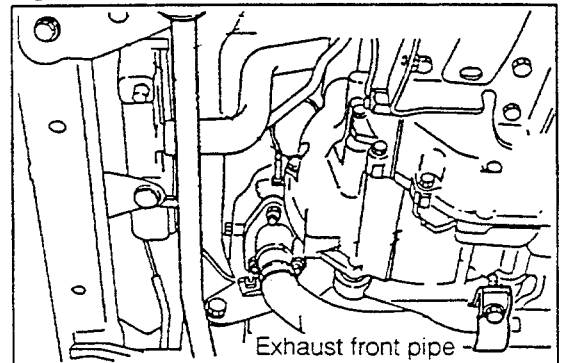

Fig. 5-18

WM-05022

26. Remove the stabilizer bar.

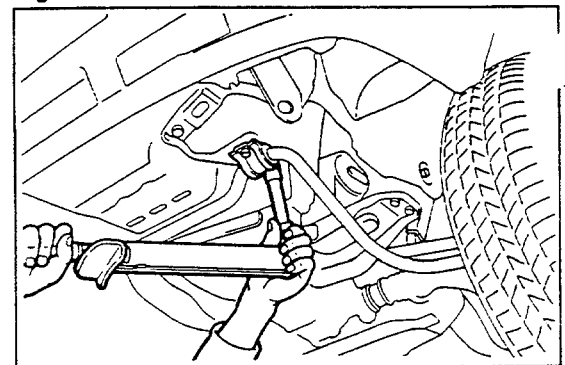

Fig. 5-19

WM-05023

27. Remove the lower suspension brace. (CB-61 and CB-80 engines only)

28. Disconnect the suspension lower arm subassembly.

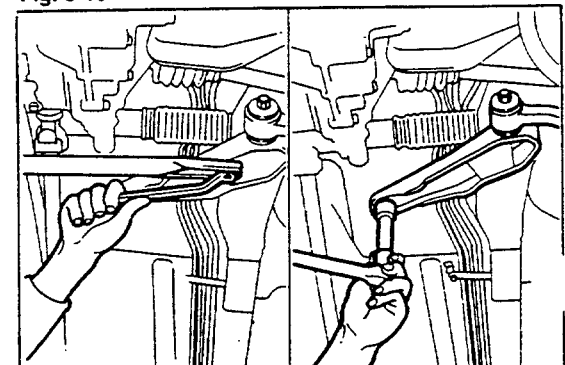

Fig. 5-20

WM-05024

l. Remove the front drive shaft.

SST: 09648-87201-000

NOTE:

① On Type CB-23 and CB-61 engines, no stopper is provided at the inside of the inboard of the drive shaft. It is, therefore, necessary to support the inboard joint section by hands during the removal.

② On Type CB-80 engine, remove the front drive shaft by inserting a crowbar into between the projected section of the drive bearing shaft and the drive shaft. Care must be exercised not to deform the dust cover of the drive shaft during the removal.

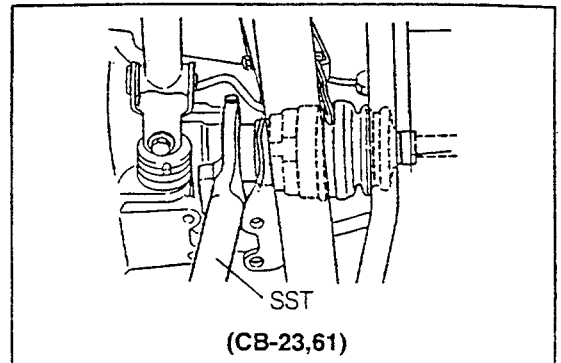

Fig. 5-21

WM-05025

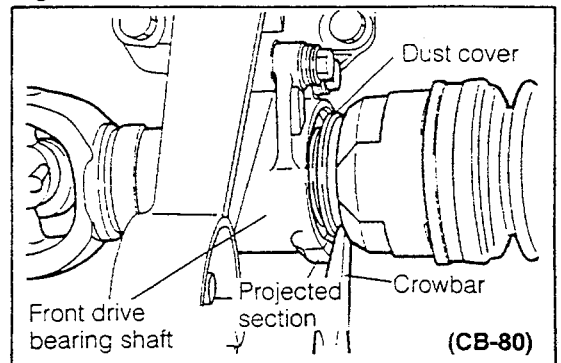

Fig. 5-22

WM-05026

30. Disconnection of engine mounting lower left bracket
Remove the bolts at the transmission side only.

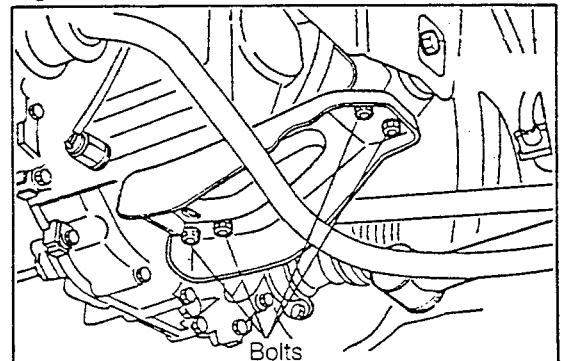

Fig. 5-23

WM-05027

31. Disconnection of engine mounting rear No.1 bracket

Remove the bolt attaching the engine lower mounting member subassembly to the engine mounting rear No.1 bracket.

WM-05028

32. Sling the engine, using the following SST.

SST: 09090-04810-000 (Engine sling device)

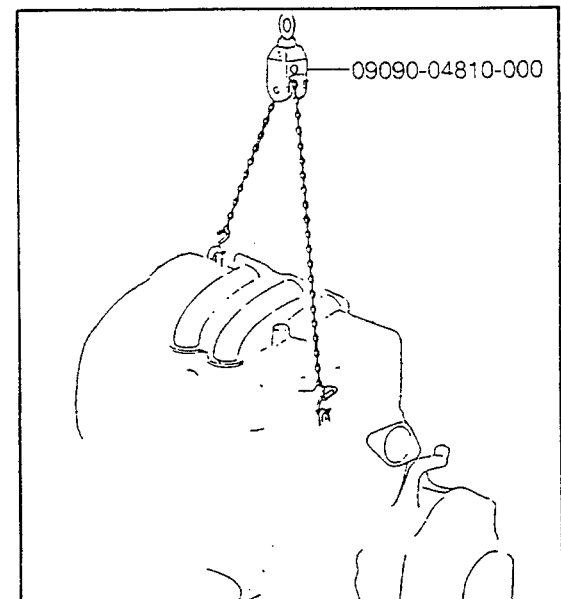

Fig. 5-24

WM-05029

ENGINE MECHANICALS

33. Removal of engine assembly

- ① Remove the engine mounting front stopper.
- ② Remove the engine mounting front insulator.
- ③ Remove the engine by lifting it, using the following SST.

SST: 09090-04810-000 (Engine sling device)

NOTE:

When removing the engine, perform final check to ensure that all removal parts have been removed.

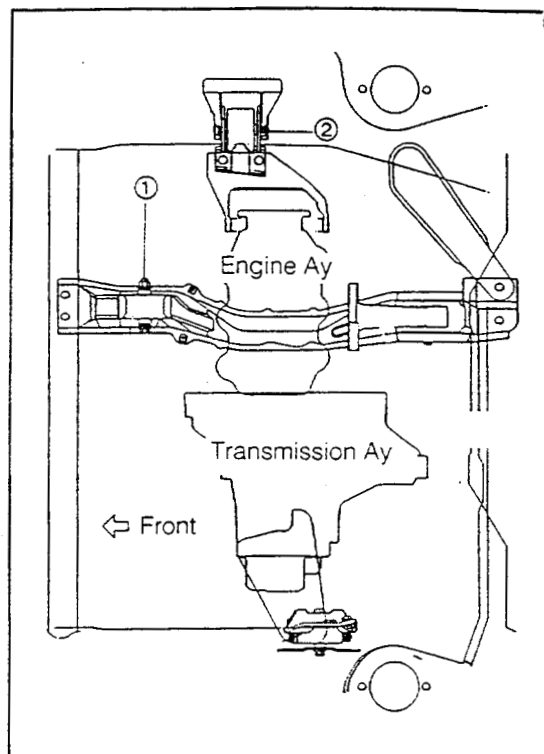

Fig. 5-25

WM-05030

34. Remove the starter assembly from the transmission.

35. Remove the transmission assembly from the engine assembly.

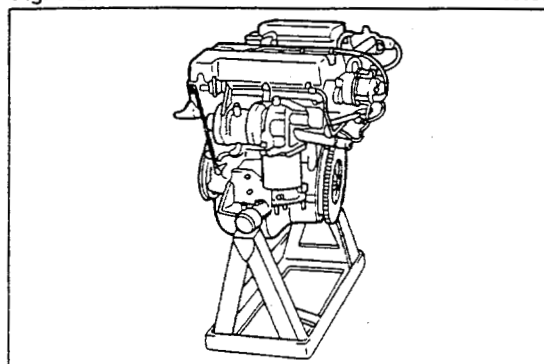

Fig. 5-26

WM-05031

36. Install the engine assembly to the following SSTs.

SSTs: 09219-87701-000

09219-87202-000

WM-05032

STALLATION

1. Remove the engine assembly from the SSTs.
2. Install the transmission assembly to the engine assembly.
Tightening Torque: 5.0 - 7.0 kg-m (36 - 51 ft-lb)
3. Install the starter assembly to the transmission.

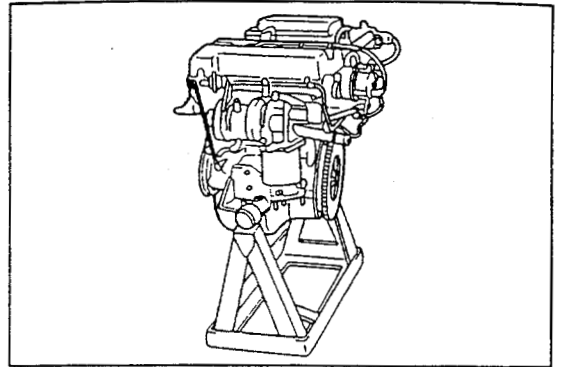

Fig. 5-27

WM-05033

4. Installation of engine assembly
 - ① Sling the engine, using the following SST.
SST: 09090-04810-000 (Engine sling device)
 - ② Install the engine mounting front insulator.
Tightening Torque: 7.5 - 10.5 kg-m (54 - 76 ft-lb)
 - ③ Install the engine mounting front stopper.
Tightening Torque: 7.5 - 10.5 kg-m (54 - 76 ft-lb)

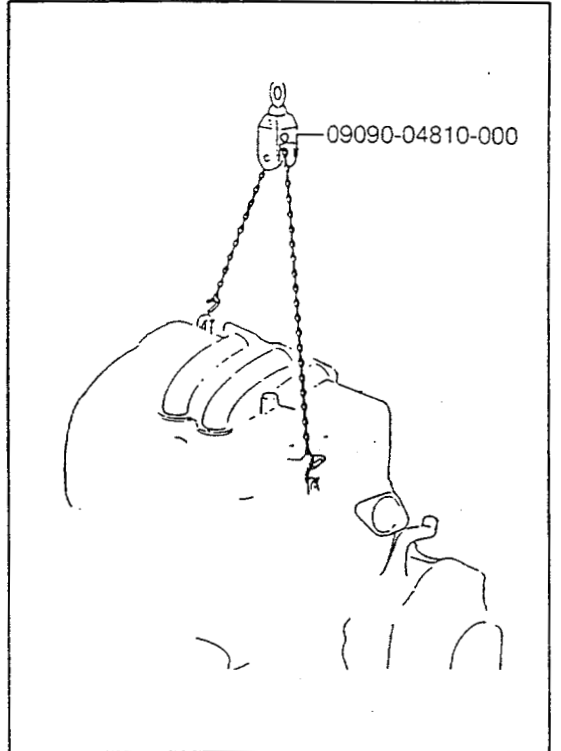

Fig. 5-28

WM-05034

5. Install the engine mounting rear No.1 bracket.
Tightening Torque: 7.5 - 10.5 kg-m (54 - 76 ft-lb)

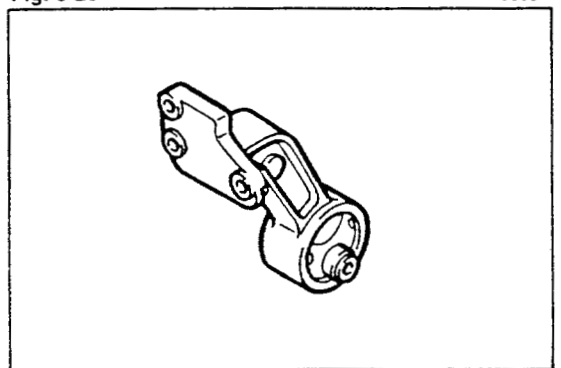

Fig. 5-29

WM-05035

6. Install the engine mounting lower left bracket.
Tightening Torque: 3.0 - 4.5 kg-m (22 - 33 ft-lb)
7. Remove the SST (engine sling device) from the engine assembly.

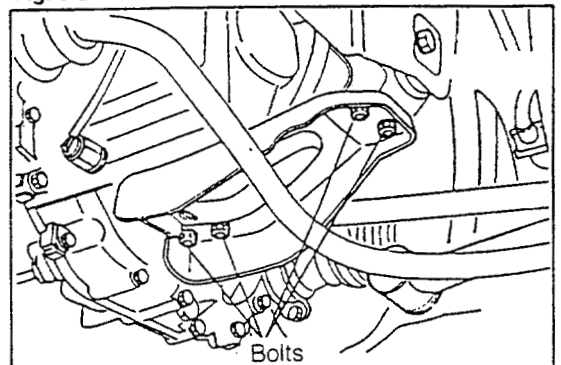

Fig. 5-30

WM-05036

ENGINE MECHANICALS

8. Install the front drive shaft.

NOTE:

Install the front drive shaft to the differential case slowly, being very careful not to damage the lip section of the oil seal.

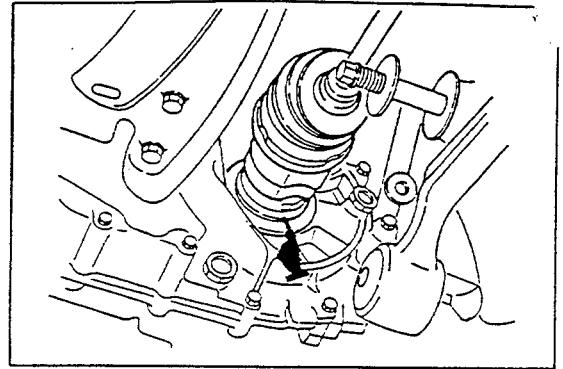

Fig. 5-31

WM-05037

9. Install the suspension lower arm subassembly.

Tightening Torque: 7.5 - 10.5 kg-m (54 - 76 ft-lb)

10. Install the lower suspension brace. (CB-61 and CB-80 engines only)

Tightening Torque: 4.0 - 5.5 kg-m (29 - 40 ft-lb)

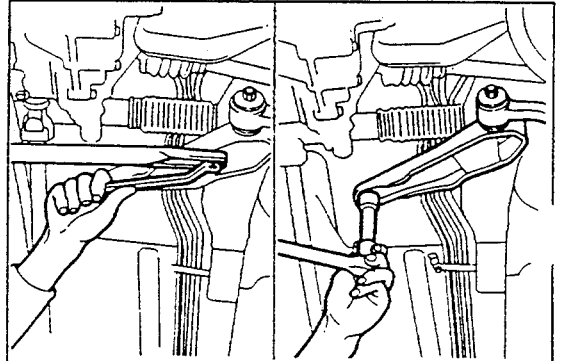

Fig. 5-32

WM-05038

11. Installation of stabilizer bar

- ① Tightening the suspension lower arm subassembly.

Tightening Torque: 7.5 - 11.0 kg-m (54 - 80 ft-lb)

- ② Tightening the stabilizer bracket.

Tightening Torque: 4.0 - 6.0 kg-m (29 - 43 ft-lb)

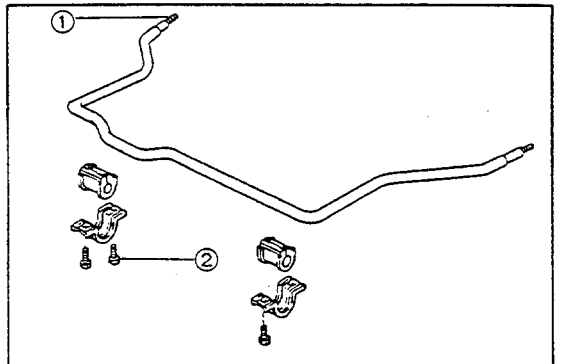

Fig. 5-33

WM-05039

12. Install the exhaust front pipe.

Tightening Torque: 3.0 - 5.0 kg-m (22 - 36 ft-lb)

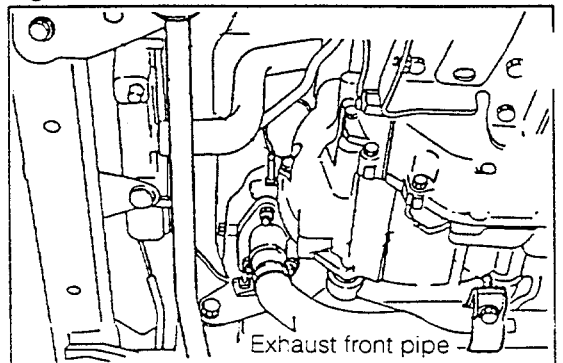

Fig. 5-34

WM-05040

13. Install the shift & selector shaft subassembly.

Tightening Torque: 1.0 - 1.6 kg-m (7 - 12 ft-lb)

NOTE:

After completion of the installation, make sure that the shift & selector shaft subassembly can be shifted smoothly into each position. Also, be sure that it can be returned smoothly in the selecting direction.

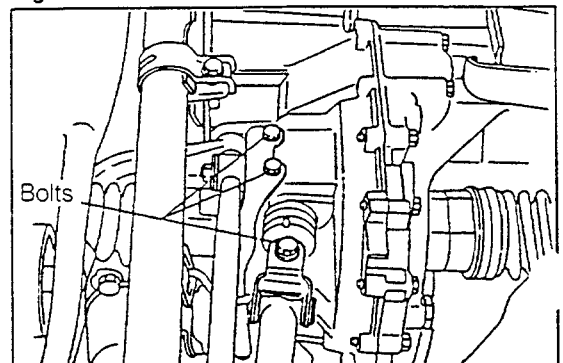

Fig. 5-35

WM-05041

14. Fill the transmission fluid.

Lubricant viscosity recommendation:

SAE 80W (oil equivalent to API classification GL-4)

Oil level	Transmission	4-speed manual transmission	5-speed manual transmission
Oil level flush with Filler plug		About 2.0 litres	About 2.2 litres
Oil level 5 mm below Filler plug		About 1.9 litres	About 2.1 litres

15. Tighten the wheels temporarily. Remove the safety stands. Tighten the wheels securely.

Tightening Torque: 9.0 - 12.0 kg-m (65 - 87 ft-lb)

16. Connect the harness connectors for the parts given below.

- 1) Alternator connector
- 2) Oil pressure switch
- 3) Earth
- 4) Intake air temperature sensor
- 5) Variable resistor
- 6) Pressure sensor
- 7) Throttle sensor
- 8) Backup lamp harness
- 9) Transmission earth
- 10) Starter harness
- 11) Coupler of each injector
- 12) Cold start injector
- 13) Ignition coil resistive cord
- 14) Distributor connector
- 15) Thermostat sender unit
- 16) Fan motor switch
- 17) Water temperature sensor
- 18) Injector time switch

17. Install the hose of the turbocharger waste gate valve.

(CB-80 engine only)

18. Install the fuel pipe.

19. Install the heater hose.

20. Install the brake booster hose.

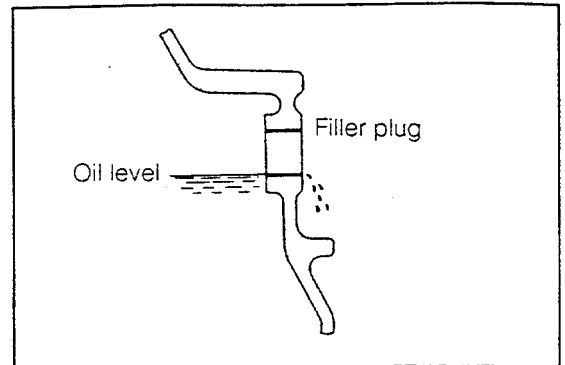

Fig. 5-36

WM-05042

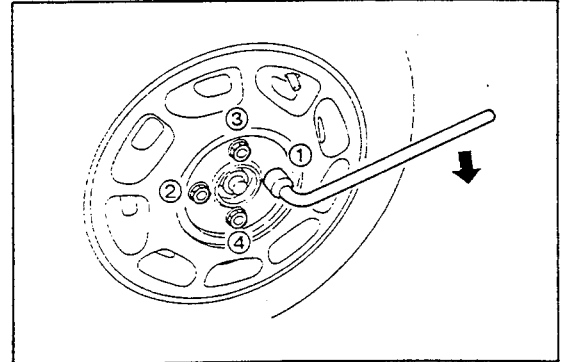

Fig. 5-37

WM-05043

WM-05044

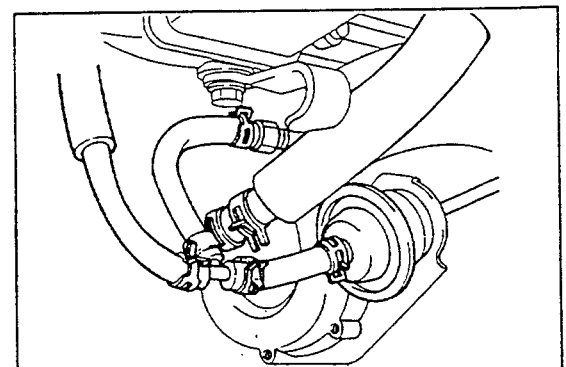

Fig. 5-38

WM-05045

ENGINE MECHANICALS

21. Connect the accelerator cable.

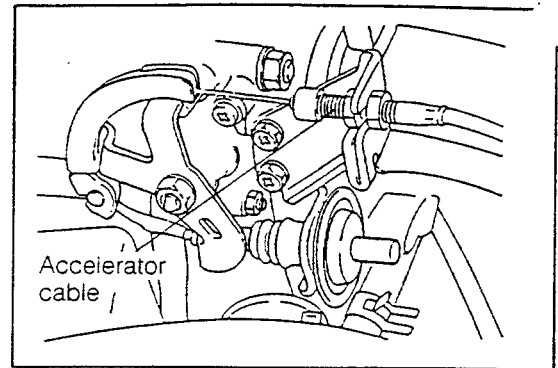

Fig. 5-39

WM-C5046

22. Connect the clutch cable.

NOTE:

Apply MP grease to the point where the clutch release lever is attached to the clutch cable.

23. Connect the speedometer cable.

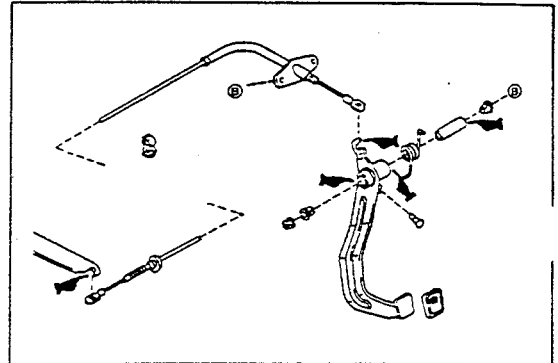

Fig. 5-40

WM-C5047

24. Install the air cleaner assembly.

25. Install the blow-by hose. (CB-61 engine only)

26. Install the radiator.

27. Install the intercooler assembly.

28. Install the battery carrier stay.

29. Install the positive \oplus terminal of the battery.

30. Install the negative \ominus terminal of the battery.

31. Install the hold-down clamp of the battery.

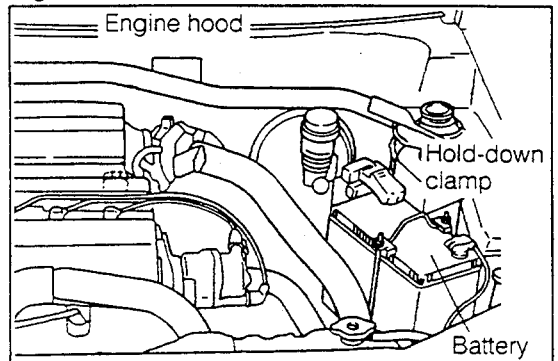

Fig. 5-41

WM-C5048

32. Install the engine hood.

NOTE:

Apply rust preventive oil to the bolt tightening sections.

(Reference)

Rust Preventive Oil

3M make

Rust Fighter-I (Aerosol Type)

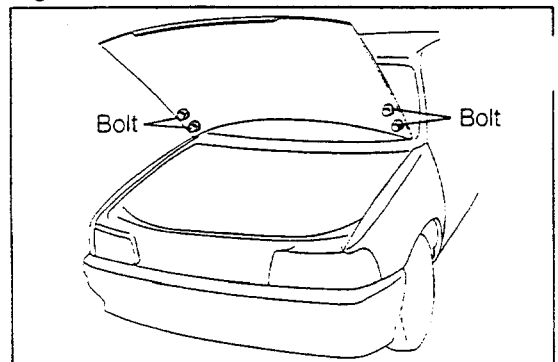

Fig. 5-42

WM-C5049

33. Fill the engine oil.

API Classification: CB23 SC-SF

CB61 and CB80 SD-SF

Lubrication oil capacity: 2.7 liter

Classification: API SC, SD, SE or SF

		CB-23	CB-61	CB-80
Engine oil capacity	litre	3.2	3.2	3.3

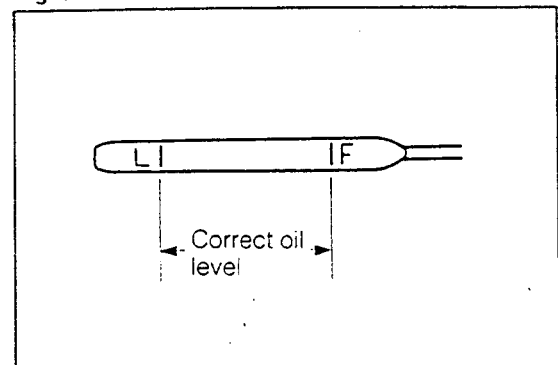

Fig. 5-43

WM-C5050

Fill the radiator tank and reserve tank with cooling water.

NOTE:

- ① After completion of the operation, make sure that no leakage exists.
- ② Put the coolant, as required.

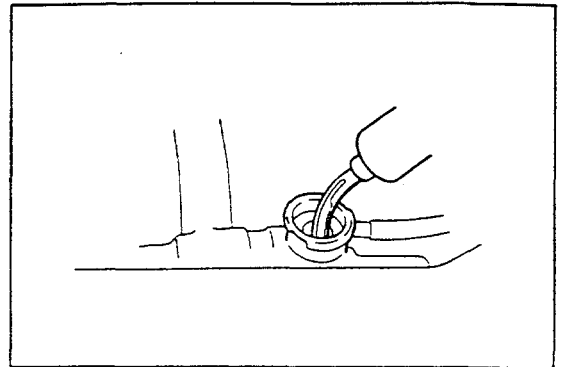

Fig. 5-44

WM-05051

Amount of coolant (When undiluted coolant with 98% concentration is used:)

[With heater]

Atmosphere temperature		Concentration	Radiator (litre)	Reserve tank (litre)
-10°C	Petrol engine (Type CB-23 engine)	Manual transmission	0.66	0.14
		Automatic transmission	0.75	0.14
	Petrol turbo engine (Type CB-61 engine)		0.75	0.14
	Petrol turbo engine (Type CB-80 engine)		0.77	0.14
	Diesel engine (Type CL-11 engine)		0.82	0.14
	Diesel turbo engine (Type CL-61 engine)		0.85	0.14
-20°C	Petrol engine (Type CB-23 engine)	Manual transmission	1.00	0.21
		Automatic transmission	1.14	0.21
	Petrol turbo engine (Type CB-61 engine)		1.14	0.21
	Petrol turbo engine (Type CB-80 engine)		1.17	0.21
	Diesel engine (Type CL-11 engine)		1.25	0.21
	Diesel turbo engine (Type CL-61 engine)		1.29	0.21
-35°C	Petrol engine (Type CB-23 engine)	Manual transmission	1.44	0.30
		Automatic transmission	1.64	0.30
	Petrol turbo engine (Type CB-61 engine)		1.64	0.30
	Petrol turbo engine (Type CB-80 engine)		1.68	0.30
	Diesel engine (Type CL-11 engine)		1.79	0.30
	Diesel turbo engine (Type CL-61 engine)		1.84	0.30

WM-05052

ENGINE MECHANICALS

INTAKE AND EXHAUST SYSTEM

CB-23 AND CB-61 ENGINES

COMPONENTS OF INTAKE AND EXHAUST SYSTEM

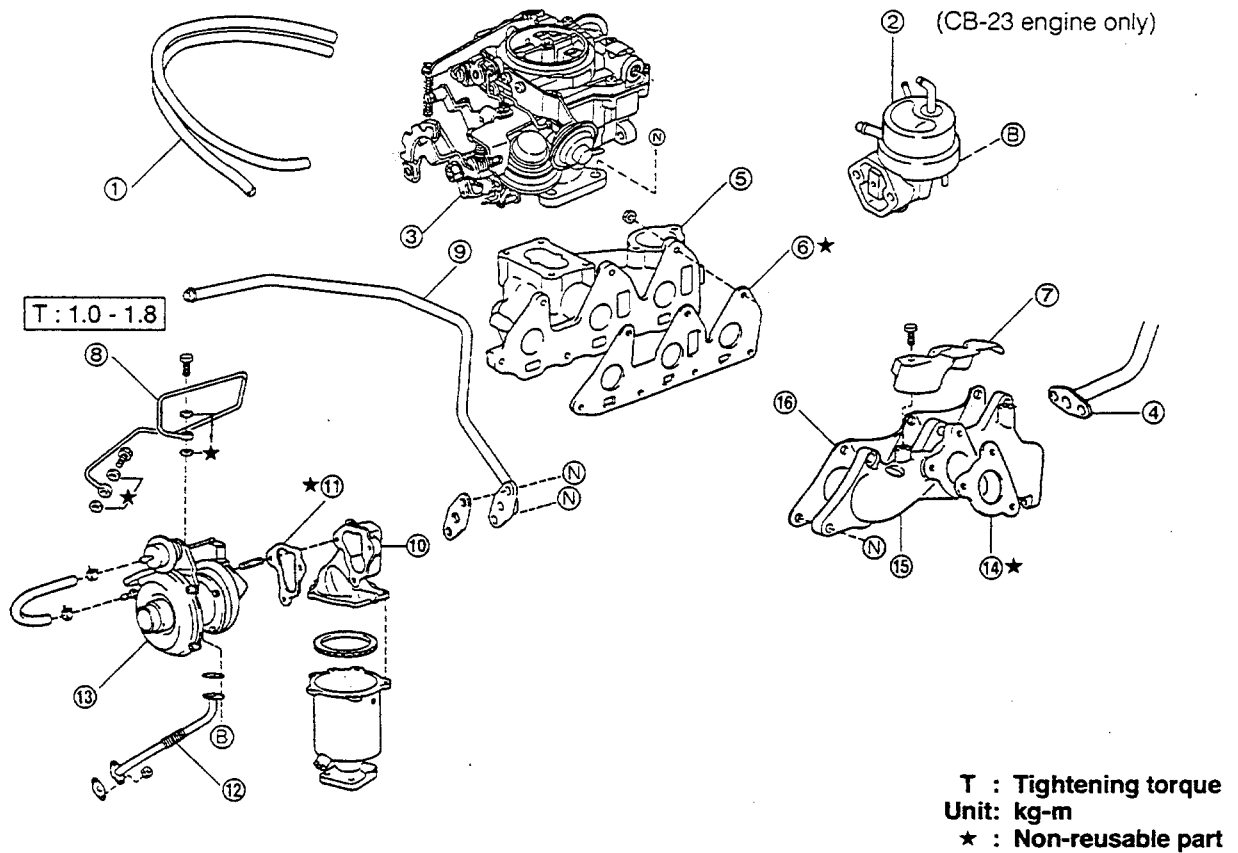

- ① Hoses
- ② Fuel pump (CB-23 engine only)
- ③ Carburetor Ay
- ④ EGR pipe (Specific area only)
- ⑤ Intake manifold Ay
- ⑥ Intake manifold-to-cylinder head gasket
- ⑦ Exhaust manifold heat insulator No.1
- ⑧ Turbocharger oil inlet (CB-61 engine only)
- ⑨ Air suction pipe (Specific area only)
- ⑩ Exhaust manifold case (CB-61 engine only)
- ⑪ Turbocharger-to-exhaust manifold gasket (CB-61 engine only)
- ⑫ Turbocharger oil outlet pipe S/A (CB-61 engine only)
- ⑬ Turbocharger Ay (CB-61 engine only)
- ⑭ Turbocharger-to-exhaust manifold gasket (CB-61 engine only)
- ⑮ Exhaust manifold Ay
- ⑯ Exhaust manifold-to-cylinder head gasket

Fig. 5-45

WM-05053

REMOVAL

1. Remove the surge tank assembly. (CB-61 engine only)
2. Remove the intake pipe. (CB-61 engine only)

NOTE:

After the intake pipe has been removed, plug the opening with adhesive tape so that no dust, etc. may get into the turbocharger turbine.

3. Remove the hoses.

NOTE:

When removing the vacuum hoses, put a tag on each removed hose so that the hoses may be installed correctly in the original position.

4. Remove the carburetor assembly.
5. Remove the fuel pump assembly. (On Type CB-61 engine, remove the bracket.)

6. Remove the EGR pipe. (Swiss specifications only)
7. Remove the intake manifold assembly.

8. Remove the exhaust manifold heat insulator No.1.
9. Remove the turbocharger oil inlet. (CB-61 engine only)
10. Remove the air suction pipe. (West German, Australian and Swiss specifications only)

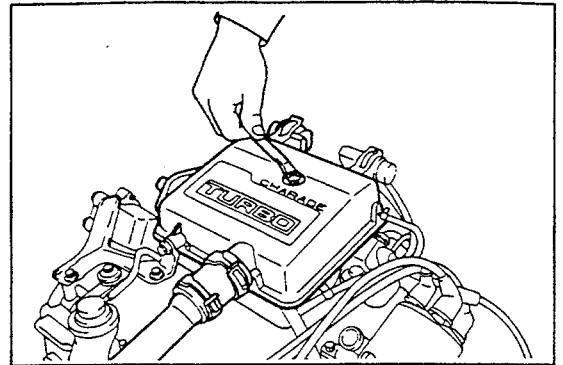

Fig. 5-46

WM-05054

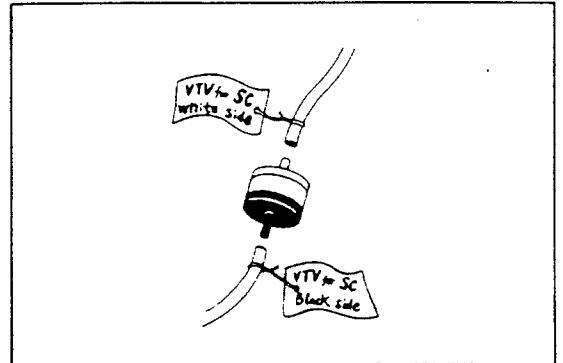

Fig. 5-47

WM-05055

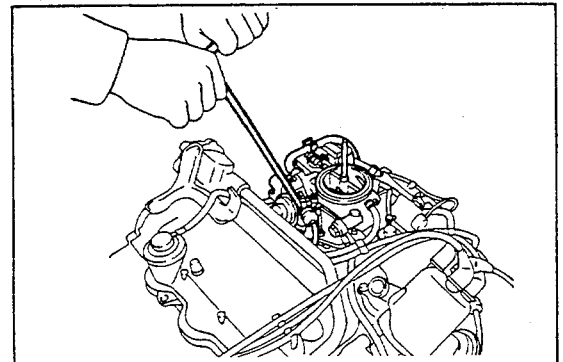

Fig. 5-48

WM-05056

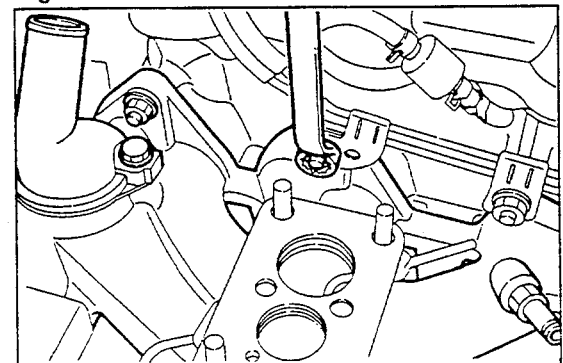

Fig. 5-49

WM-05057

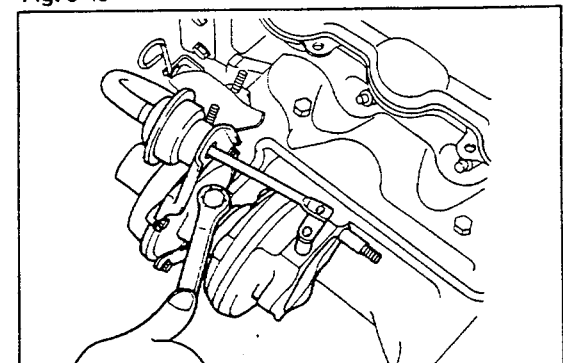

Fig. 5-50

WM-05058

ENGINE MECHANICALS

11. Remove the exhaust manifold case. (CB-61 engine only)

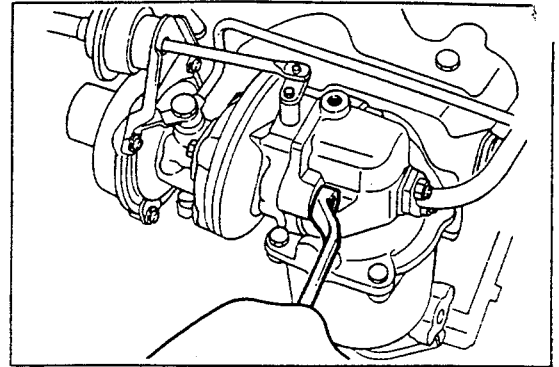

Fig. 5-51

WM-05059

12. Remove the turbocharger oil outlet pipe subassembly. (CB-61 engine only)

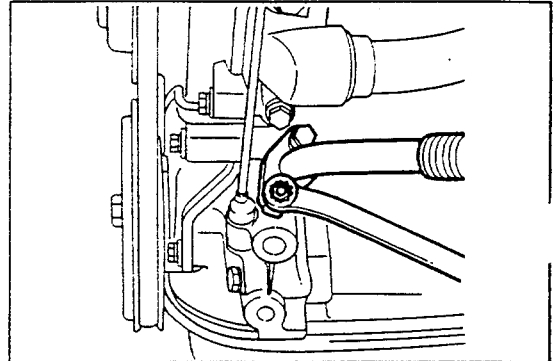

Fig. 5-52

WM-05060

13. Remove the turbocharger assembly. (CB-61 engine only)

NOTE:

For the handling instructions on the removed turbocharger assembly, see page 9-3.

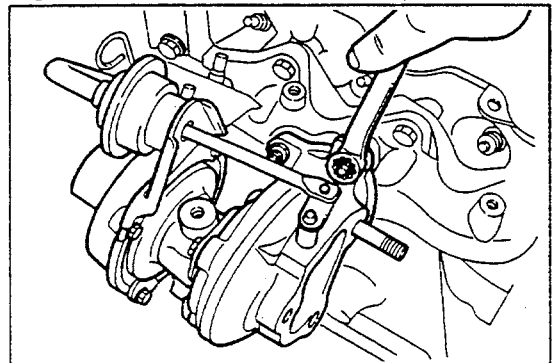

Fig. 5-53

WM-05061

14. Remove the exhaust manifold.

15. Remove the exhaust manifold-to-cylinder head gasket.

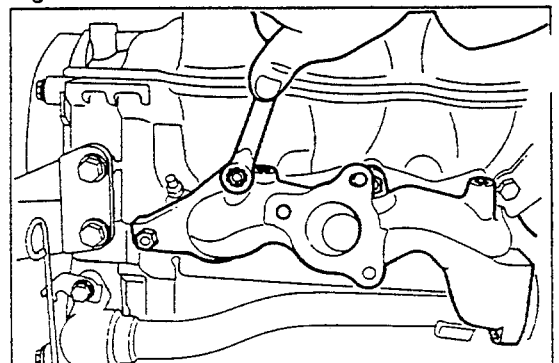

Fig. 5-54

WM-05062

INSPECTION

1. Check the cylinder head attaching surface of the intake manifold for distortion. Measure the distortion on the diagonal lines.

Allowable Limit (both intake and exhaust manifolds):

0.1 mm (0.0039 inch)

If the distortion exceeds the allowable limit, correct the surface by grinding it. However, this grinding amount should be limited to 0.3 mm (0.012 inch).

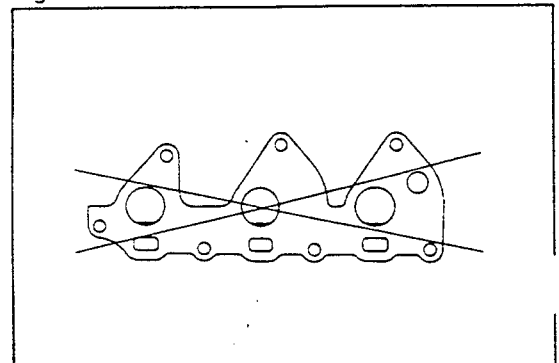

Fig. 5-55

WM-05063

- Check the EGR valve. (See the section under "Exhaust Emission Control System" (page 12-28).)
3. Check the BSV and TVSV. (See the section under "Exhaust Emission Control System" (page 12-23).)
 4. Check the turbocharger. (See the section under "Turbocharger Check" (page 9-4).)
 5. Check the carburetor. (See the section under "Carburetor Check" (page 6-5).)

WM-05064

INSTALLATION

1. Install the exhaust manifold-to-cylinder head gasket.
2. Install the exhaust manifold.
Tightening Torque: 1.0 - 1.6 kg-m (7 - 12 ft-lb)
3. Install the turbocharger-to-exhaust manifold gasket.
 (CB-61 engine only)

NOTE:

This gasket is a nonreusable part.

4. Install the turbocharger assembly. (CB-61 engine only)

NOTE:

For the handling instructions on the turbocharger assembly, see page 9-3.

Tightening Torque: 2.5 - 3.3 kg-m (18 - 24 ft-lb)

5. Install the turbocharger oil outlet pipe subassembly.

6. Install the exhaust manifold case. (CB-61 engine only)

Tightening Torque: 3.0 - 4.0 kg-m (22 - 29 ft-lb)

7. Install the air suction pipe.
 (West German, Australian and Swiss specifications only)

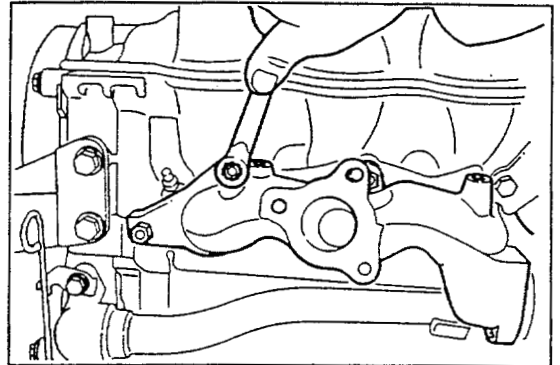

Fig. 5-56

WM-05065

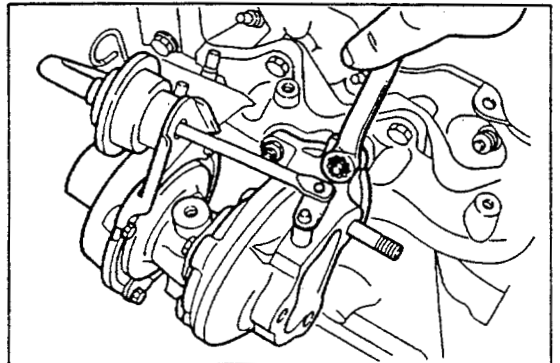

Fig. 5-57

WM-05066

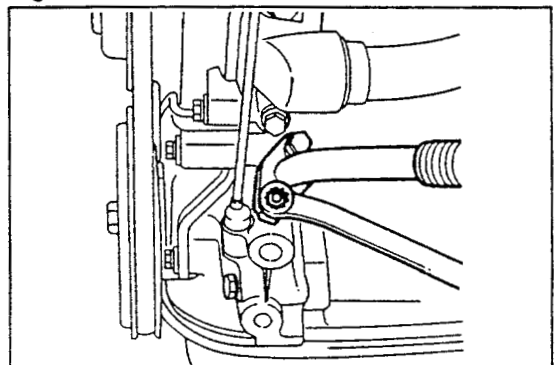

Fig. 5-58

WM-05067

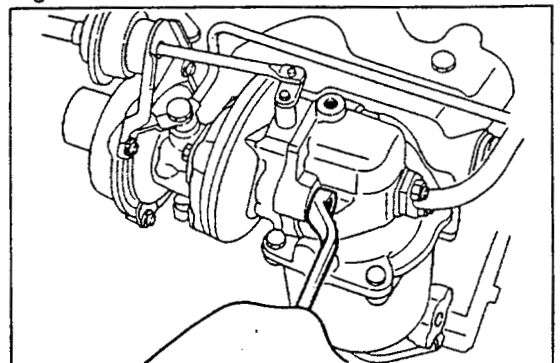

Fig. 5-59

WM-05068

ENGINE MECHANICALS

8. Install the turbocharger oil inlet. (CB-61 engine only)

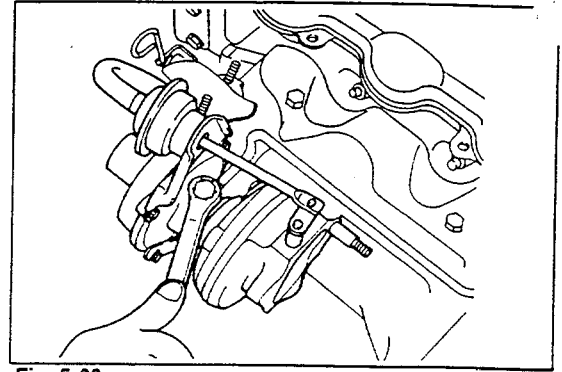

Fig. 5-60

WM-05069

9. Install the exhaust manifold heat insulator No.1.
10. Install the intake manifold-to-cylinder head gasket.
11. Install the intake manifold.

Tightening Torque: 1.0 - 1.6 kg-m (7 - 12 ft-lb)

NOTE:

This gasket is a nonreusable part.

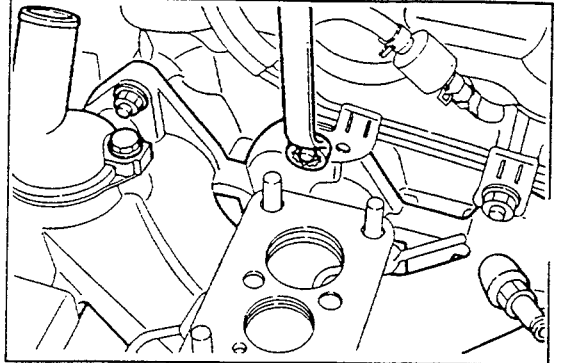

Fig. 5-61

WM-05070

12. Install the EGR pipe. (Swiss specifications only)
13. Install the carburetor assembly.
14. Install the fuel pump assembly. (On Type CB-61 engine, install the bracket.)

NOTE:

This gasket is a nonreusable part.

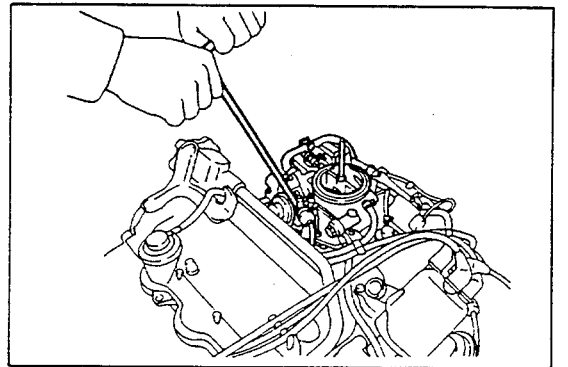

Fig. 5-62

WM-05071

15. Install the hoses.

NOTE:

Be sure to install the hoses correctly in accordance with the tags put during the removal.

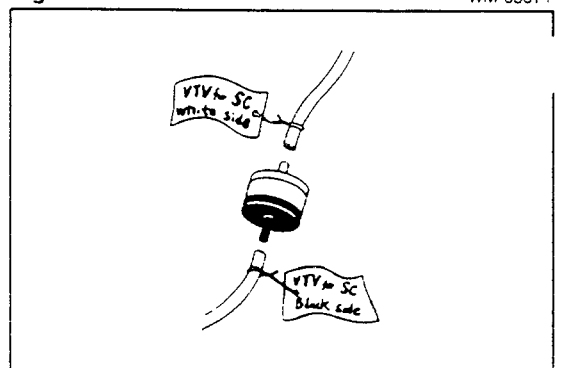

Fig. 5-63

WM-05072

16. Install the intake pipe. (CB-61 engine only)
17. Install the surge tank assembly. (CB-61 engine only)

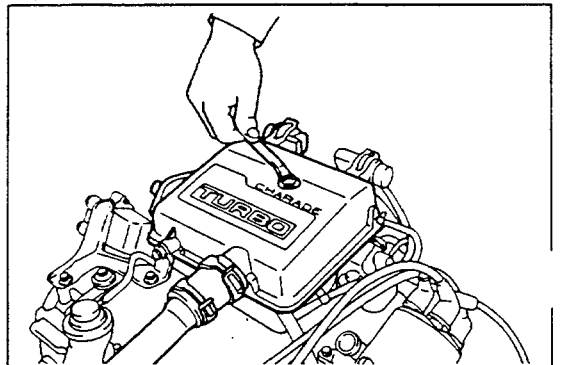
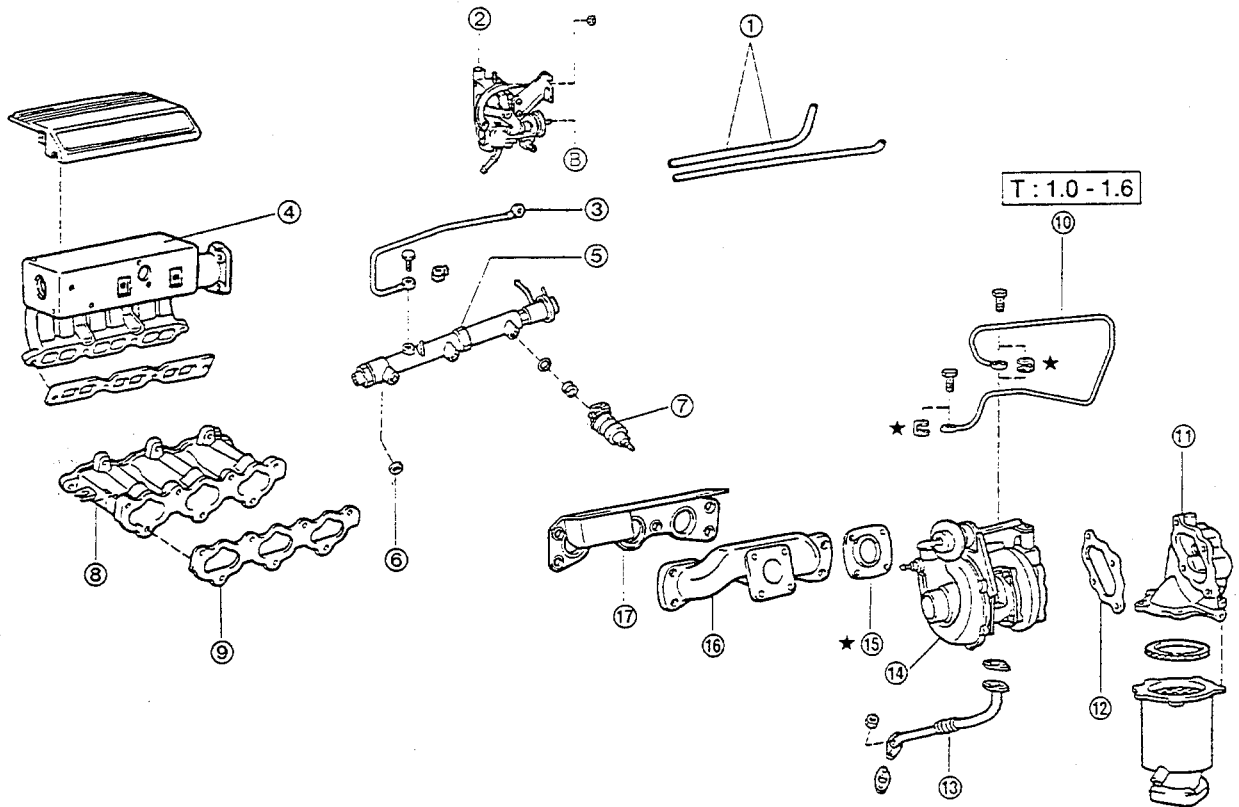

Fig. 5-64

WM-05073

3-80 ENGINE
COMPONENTS OF INTAKE AND EXHAUST SYSTEM



(1)
T : Tightening torque
Unit: kg-m
★ : Non-reusable part

- ① Hoses
- ② Throttle body
- ③ Fuel pipe (Cold start injector)
- ④ Air surge tank
- ⑤ Fuel delivery pipe
- ⑥ Fuel delivery pipe insulator
- ⑦ Fuel injector Ay
- ⑧ Intake manifold
- ⑨ Intake manifold-to-cylinder head gasket
- ⑩ Turbocharger oil inlet pipe S/A
- ⑪ Exhaust manifold case
- ⑫ Turbocharger-to-exhaust manifold gasket
- ⑬ Turbocharger oil outlet pipe S/A
- ⑭ Turbocharger Ay
- ⑮ Turbocharger-to-exhaust manifold gasket
- ⑯ Exhaust manifold Ay
- ⑰ Exhaust manifold-to-cylinder head gasket

Fig. 5-65

WM-05074

ENGINE MECHANICALS

REMOVAL

1. Remove the hoses.

NOTE:

When removing the vacuum hoses, put a tag on each removed hose so that the hoses may be installed correctly in the original position.

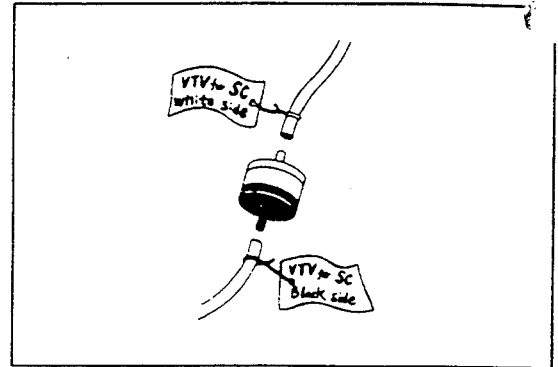

Fig. 5-66

WM-05075

2. Remove the surge tank cover.
3. Remove the fuel pipe for cold start injector use.

NOTE:

When removing the pipe, the fuel will be discharged. Hence, be sure to get a cloth ready to receive the fuel.

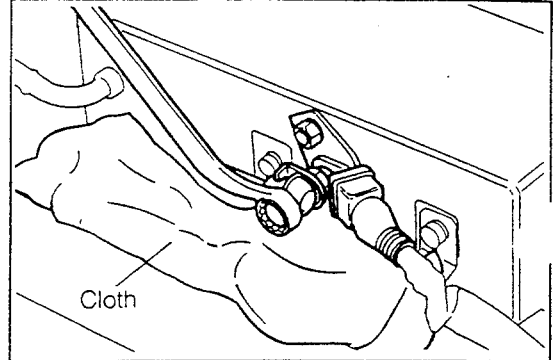

Fig. 5-67

WM-05076

4. Remove the throttle body.

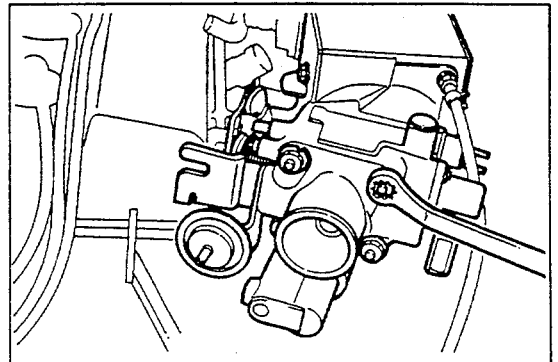

Fig. 5-68

WM-05077

5. Remove the air surge tank assembly.
6. Remove the fuel delivery pipe.
7. Remove the fuel delivery pipe insulator.

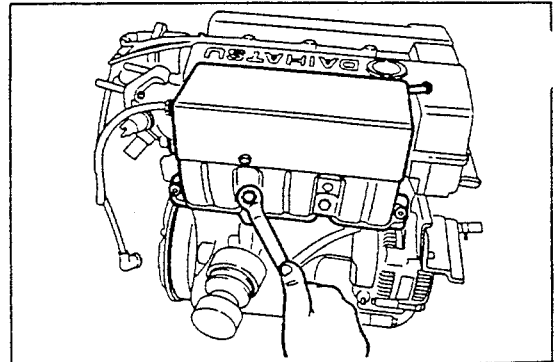

Fig. 5-69

WM-05078

8. Remove the intake manifold.

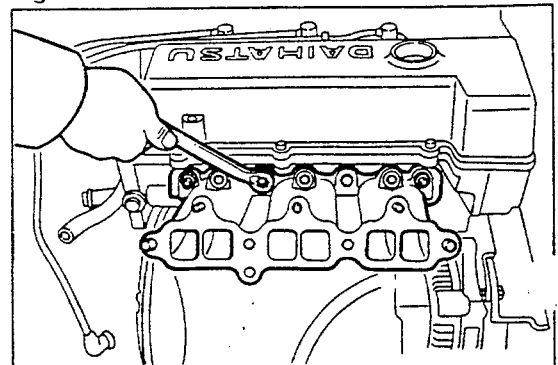

Fig. 5-70

WM-05079

- Remove the turbocharger oil inlet pipe subassembly.
 10. Remove the exhaust manifold case.

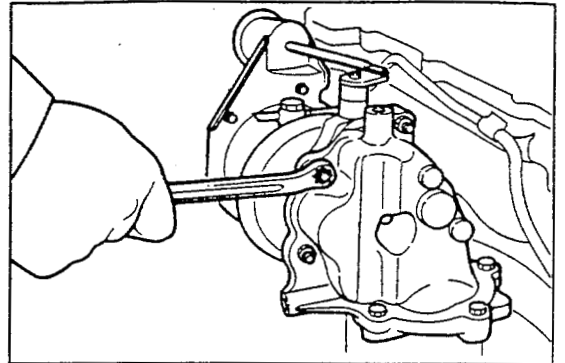

Fig. 5-71

WM-05080

11. Remove the turbocharger oil outlet pipe subassembly.

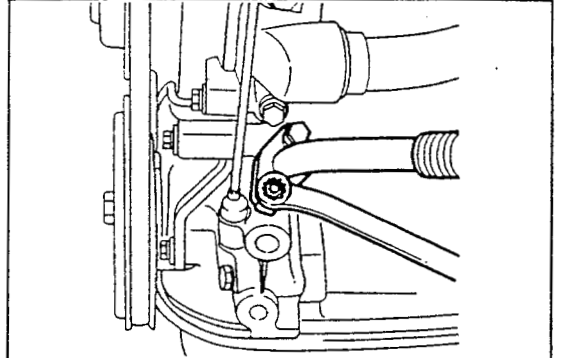

Fig. 5-72

WM-05081

12. Remove the turbocharger assembly.

NOTE:

For the handling instructions on the removed turbocharger assembly, see page 9-3.

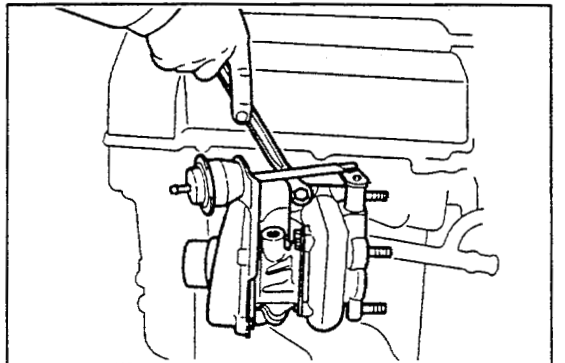

Fig. 5-73

WM-05082

13. Remove the exhaust manifold.
 Remove the exhaust manifold-to-cylinder head gasket.

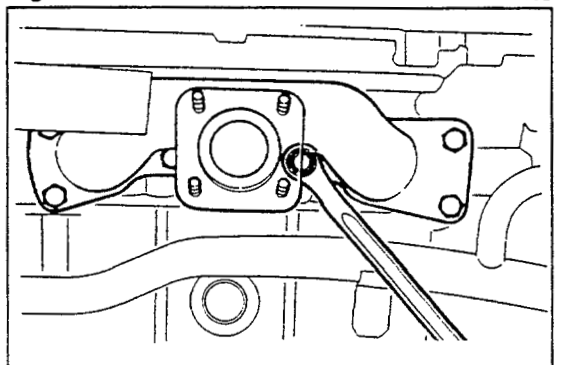

Fig. 5-74

WM-05083

INSPECTION

1. Check the surge tank and cylinder head attaching surfaces of the intake manifold for distortion. Measure the distortion on the diagonal lines.

Allowable Limit: 0.1 mm (0.0039 inch)

If the distortion exceeds the allowable limit, correct the surface by grinding it. However, this grinding amount should be limited to 0.3 mm (0.012 inch).

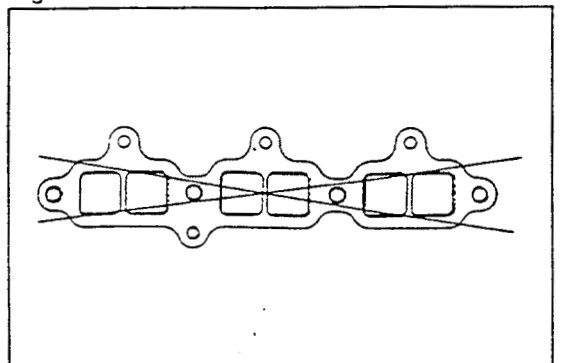

Fig. 5-75

WM-05084

ENGINE MECHANICALS

2. Check the turbocharger. (See the section under "Turbocharger Check" (page 9-4).)

WM-05085

INSTALLATION

1. Install the exhaust manifold-to-cylinder head gasket.

NOTE:

When installing a new gasket, install it with the projected section facing toward the manifold side.

2. Install the exhaust manifold.

Tightening Torque: 4.0 - 5.0 kg-m (29 - 36 ft-lb)

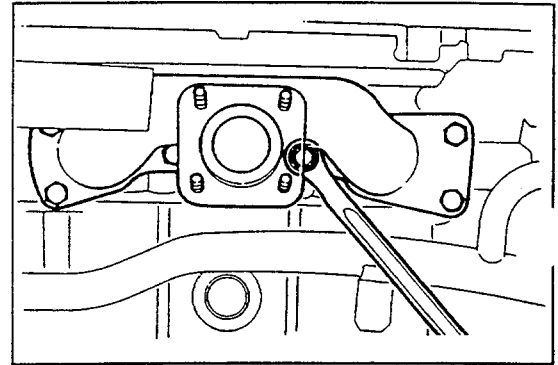

Fig. 5-76

WM-05086

3. Install the turbocharger assembly.

NOTE:

For handling instructions on the turbocharger assembly prior to its assembly, see page 9-3.

Tightening Torque: 2.5 - 3.3 kg-m (18 - 24 ft-lb)

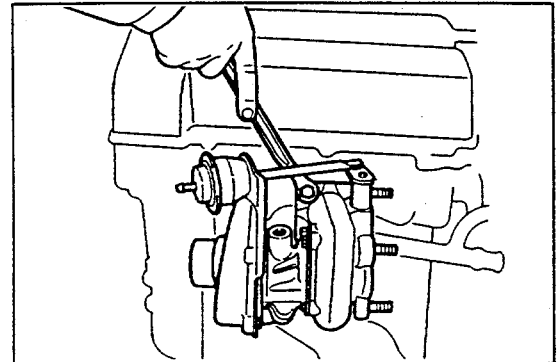

Fig. 5-77

WM-05087

4. Install the turbocharger oil outlet pipe subassembly.

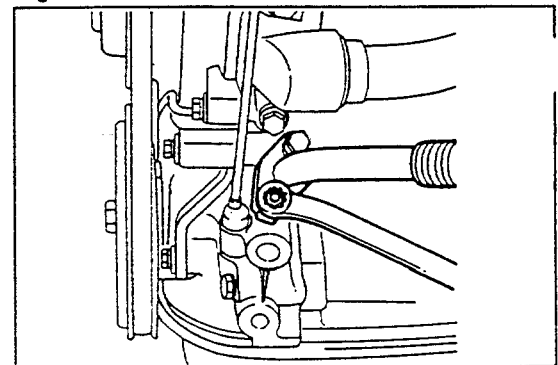

Fig. 5-78

WM-05088

5. Install the exhaust manifold case.

Tightening Torque: 2.5 - 3.3 kg-m (18 - 24 ft-lb)

6. Install the turbocharger oil inlet pipe subassembly.

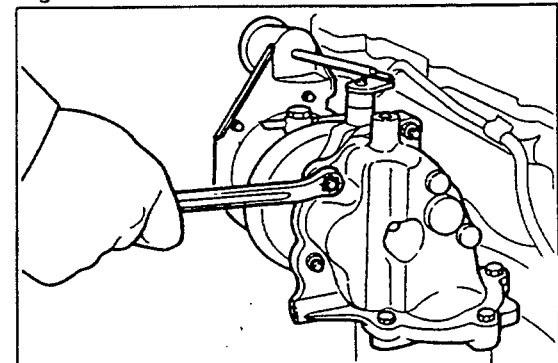

Fig. 5-79

WM-05089

Install the intake manifold.

Tightening Torque: 1.7 - 2.5 kg-m (12 - 18 ft-lb)

NOTE:

The gasket is a nonreusable part.

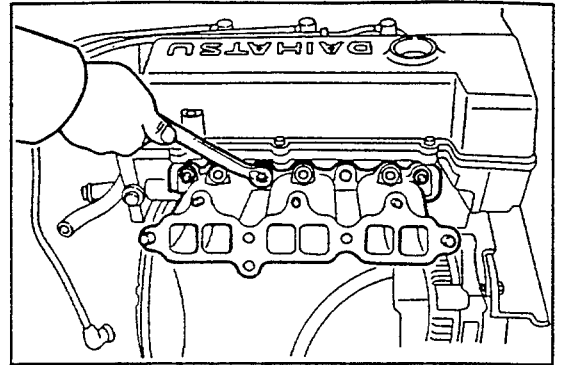

Fig. 5-80

WM-05090

8. Install the fuel delivery pipe insulator.
9. Install the fuel injector.

WM-05091

10. Install the fuel delivery pipe.
11. Install the air surge tank assembly.
Tightening Torque: 3.5 - 4.5 kg-m (25 - 32 ft-lb)

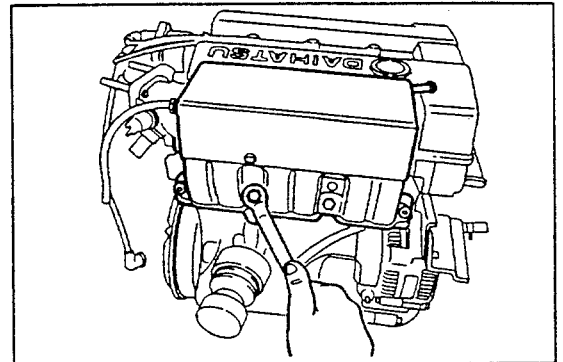

Fig. 5-81

WM-05092

12. Install the throttle body.
 - Install the fuel pipe (for cold start injector use)

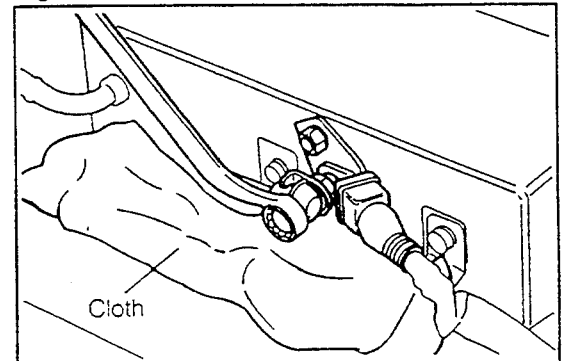

Fig. 5-82

WM-05093

14. Install the hoses.

NOTE:

Be sure to install the hoses correctly according to the tags which were put during the removal.

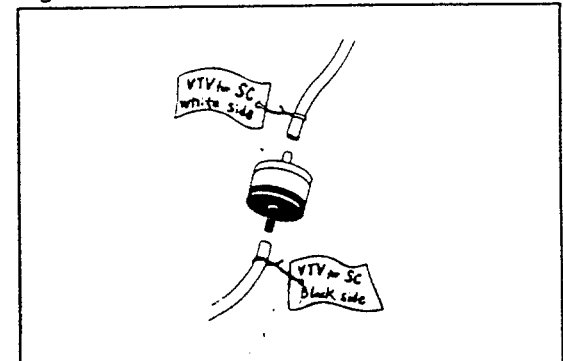
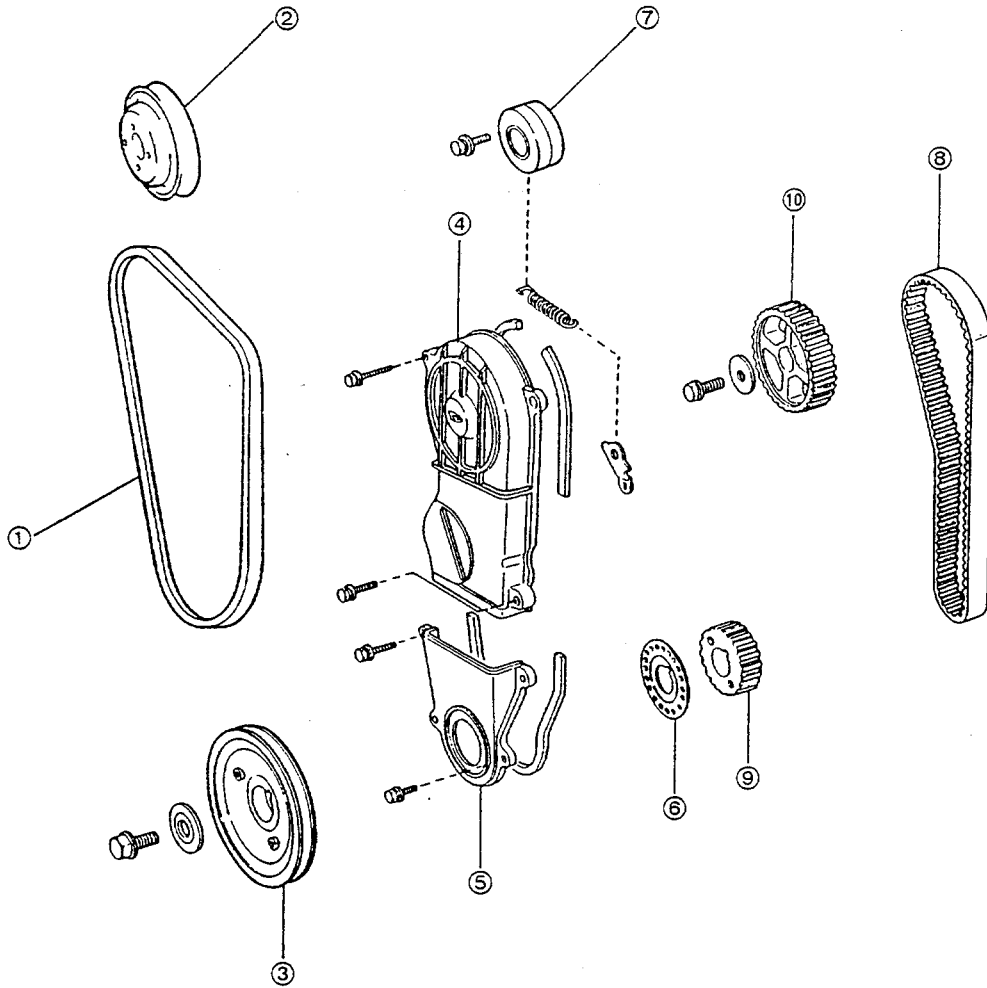

Fig. 5-83

WM-05094

TIMING BELT

**CB-23 AND CB-61 ENGINES
COMPONENTS OF TIMING BELT**



- ① V-belt
- ② Water pump pulley
- ③ Crank shaft pulley
- ④ Timing belt upper cover
- ⑤ Timing belt lower cover
- ⑥ Crankshaft timing belt pulley flange
- ⑦ Timing belt tensioner
- ⑧ Timing belt
- ⑨ Crankshaft timing belt pulley
- ⑩ Crankshaft timing belt pulley

Fig. 5-84

REMOVAL

1. Remove the V-belt.
2. Remove the water pump pulley.
3. Remove the crankshaft pulley.
When slackening the attaching bolt of the crankshaft pulley, use the following SST to prevent the ring gear from turning.

SST: 09210-87701-000

4. Remove the timing belt upper cover.
5. Remove the timing belt lower cover.
6. Remove the crankshaft timing belt pulley flange.
7. Remove the timing belt tensioner subassembly.
When removing the timing belt tensioner subassembly, set the piston No.1 to the top dead center under the compression stroke.
(Before removing the timing belt tensioner, align the punch marks of the crankshaft and camshaft timing belt pulleys with the indicators, respectively.)

NOTE:

After the timing belt tensioner has been removed, under no circumstances should the camshaft or the crankshaft be rotated. If they should be rotated, the piston will interfere with the valves, resulting in damage to these parts.

8. Remove the timing belt.
Prior to the timing belt removal, put a mark which shows the normal rotating direction at the back surface of the timing belt, using chalk or the like.

NOTE:

While removing the timing belt, make sure not to bend the belt sharply to form a small radius.
When removing the timing belt, never use a screwdriver or the like.

9. Remove the crankshaft timing belt pulley, as follows:
Screw in M8 bolts. Remove the crankshaft timing belt pulley together with the bolts.

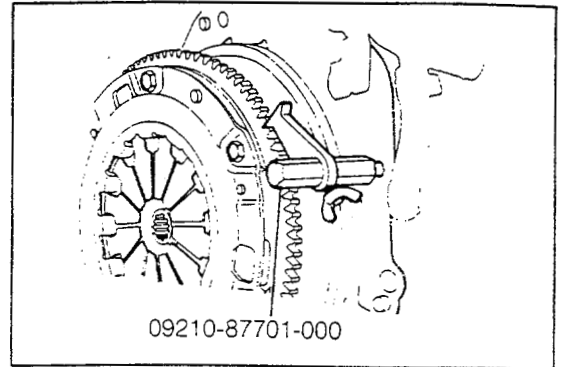

Fig. 5-85

WM-05096

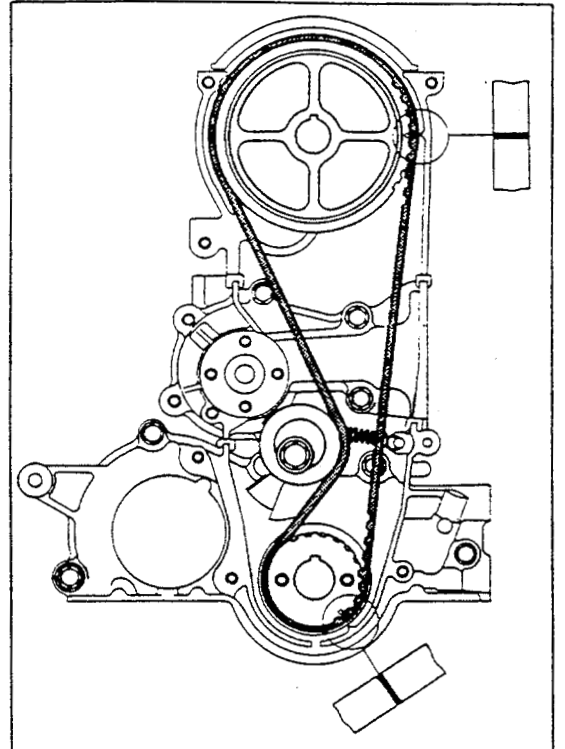

Fig. 5-86

WM-05097

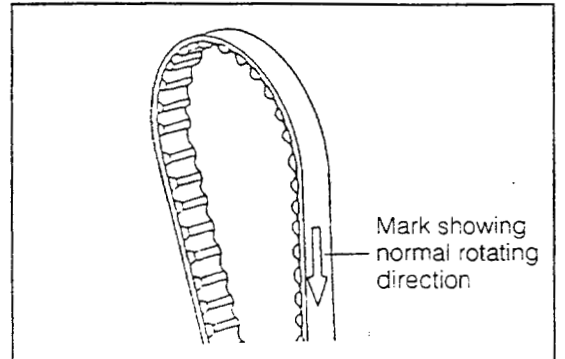

Fig. 5-87

WM-05098

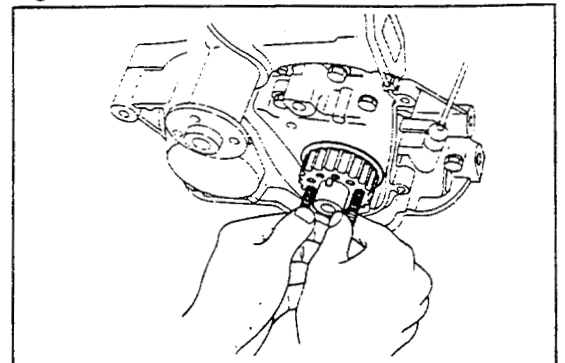

Fig. 5-88

WM-05099

ENGINE MECHANICALS

10. Remove the camshaft timing belt pulley.

During the timing belt pulley removal, the rotation of the camshaft can be prevented by inserting a screwdriver through the opening of the pulley.

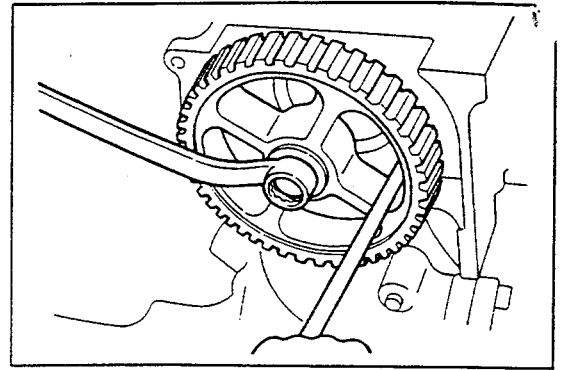

Fig. 5-89

WM-05100

INSPECTION

1. Checking of timing belt

Check each section of the timing belt. Replace the belt which exhibits the following damage.

(1) Cracks at rubber portion of back surface

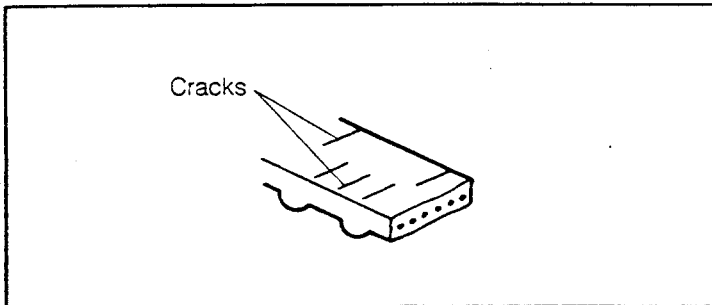

(2) Cracks at tooth bottom and peeling off and cracks at canvas

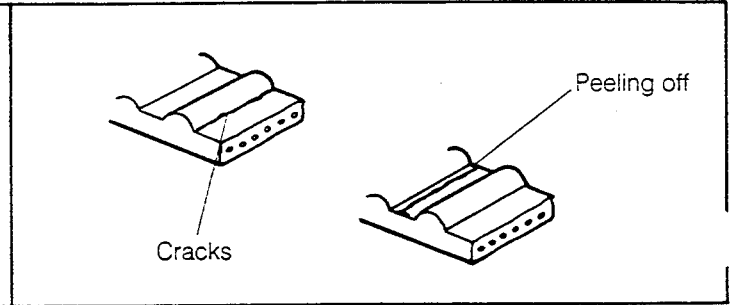

(3) Wear at canvas and tooth missing

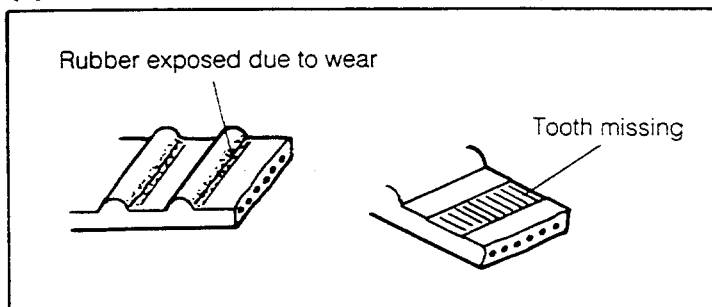

(4) Abnormal wear at side surface of belt

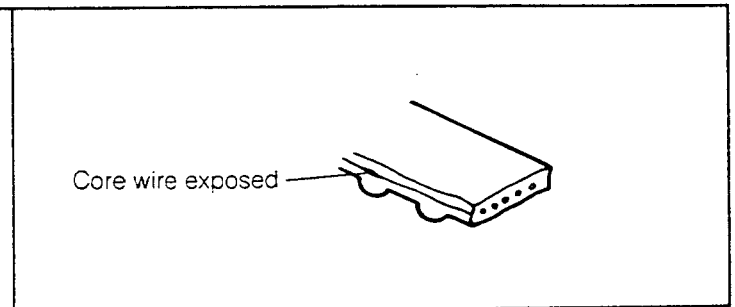

Replace the belt in the following cases, even if no external damage is observed.

- (1) Case where the timing belt has been continuously exposed to water owing to water leakage of the water pump, etc.
- (2) Case where the rubber may have swollen because of a large amount of oil stuck on the timing belt.
- (3) Case where most likely excessive force has been applied to the timing belt due to a camshaft seizure.

WM-05101

Checking of timing belt tensioner

Turn the tensioner. Check the bearing for a lock condition and abnormal noise. Also check the belt contact surface for damage.

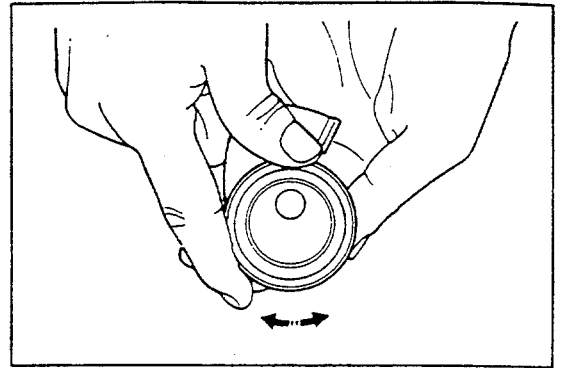

Fig. 5-90

WM-05102

3. Checking of timing belt pulley

Wear limit of timing belt pulley

mm (inches)

Crankshaft timing belt pulley	59.2 (2.331)
Camshaft timing belt pulley	119.8 (4.717)

When the wear exceeds the wear limit, replace the timing belt pulley.

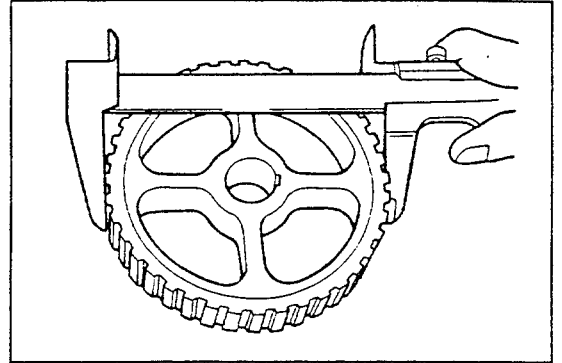

Fig. 5-91

WM-05103

4. Checking of crankshaft timing belt pulley flange

Check the crankshaft timing belt pulley flange for deformation or damage.

WM-05104

ENGINE MECHANICALS

INSTALLATION

1. Install the camshaft timing belt pulley.
To prevent the rotation of the camshaft, apply a metal rod to the rib section of the cylinder head.
(Be sure not to turn the camshaft while the timing belt pulley is being installed.)

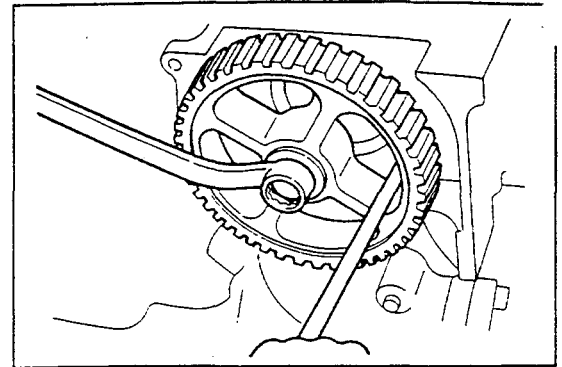

Fig. 5-92

WM-05105

2. Install the crankshaft timing belt pulley.
3. Install the timing belt tensioner subassembly.
Temporarily attach the timing belt tensioner.
The setting bolt of the timing belt tensioner should be backed off about half a turn from the completely tightened position.
Install the tension spring bracket and tension spring.

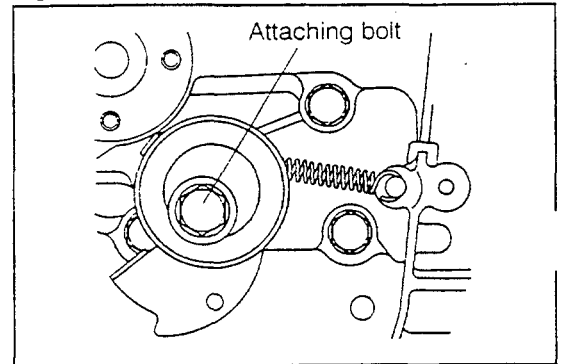

Fig. 5-93

WM-05106

4. Install the timing belt.

NOTE:

- ① Make sure not to bend the belt sharply to form a small radius. Such practice will cut the belt cord.
- ② Never permit oils, greases or water to get to the belt.
- ③ When installing the belt, never try to pry the timing belt with a screwdriver or the like.
- ④ When turning the engine with the belt installed, the rotation should be made at the crankshaft side.
- ⑤ If the belt is reused, install the belt in such a way that the belt is turned in the same direction as indicated by the arrow mark which was put at the belt's back surface during the belt removal.

WM-05107

- (1) Ensure that the punch marks of the crankshaft and camshaft timing belt pulleys are aligned with the indicator marks, respectively.
- (2) Ensure that two mating marks at the back surface of the belt are aligned with the punch marks of the camshaft and crankshaft timing belt pulleys, respectively. Also, be certain that the belt is not slackened.

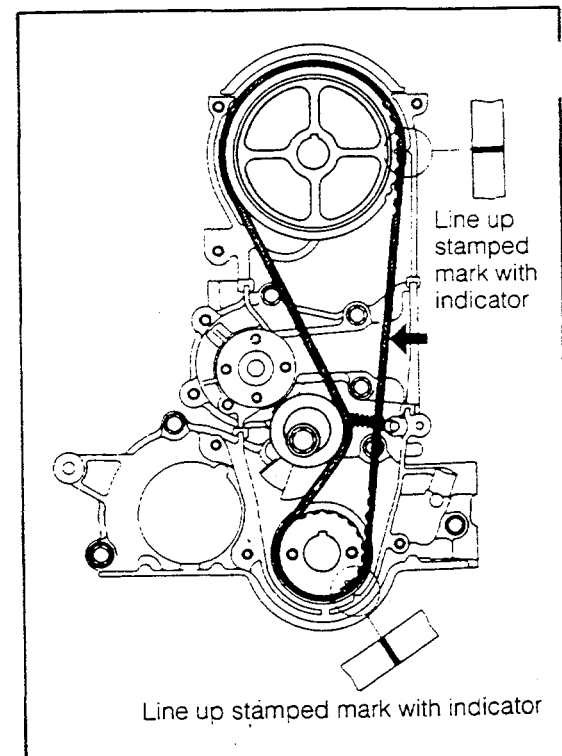

Fig. 5-94

WM-05108

- 3) Turn the crankshaft two turns in the normal rotating direction (clockwise), until the piston No.1 comes between the point 30° before the top dead center and the top dead center.

NOTE:

Never make a reverse rotation when turning the crankshaft.

- (4) Tighten the attaching bolt of the timing belt tensioner.

NOTE:

Do not push the tensioner by your finger, etc. during this operation.

Tightening Torque: 2.0 - 3.0 kg-m (14 - 22 ft-lb)

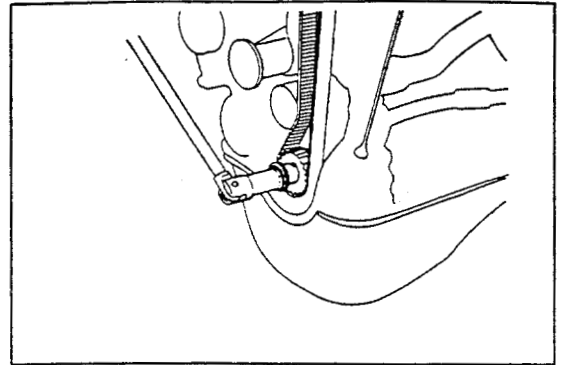

Fig. 5-95

WM-C5109

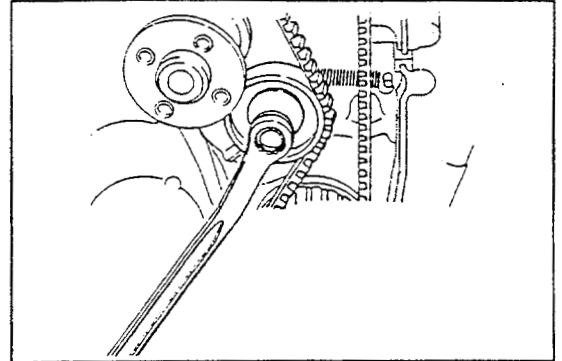

Fig. 5-96

WM-05110

- (5) Turn the crankshaft, until the piston No.1 comes at the top dead center under the compression stroke.
- (6) Ensure that the punch marks of the crankshaft and camshaft timing belt pulley are aligned with the indicators, respectively.
At this time, however, the two mating marks at the back surface of the timing belt are not aligned with the punch marks, respectively.

WM-05111

5. Install the crankshaft timing belt pulley flange.
The crankshaft timing belt pulley flange should be installed only in the correct direction.

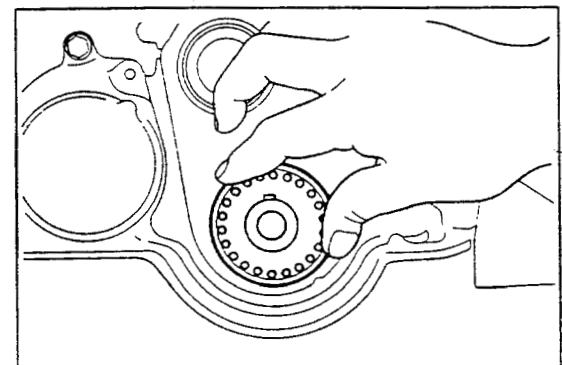

Fig. 5-97

WM-05112

6. Install the timing belt lower cover.
7. Install the timing belt upper cover.
8. Install the crankshaft pulley.
9. Install the water pump pulley.
10. Install the V-belt.

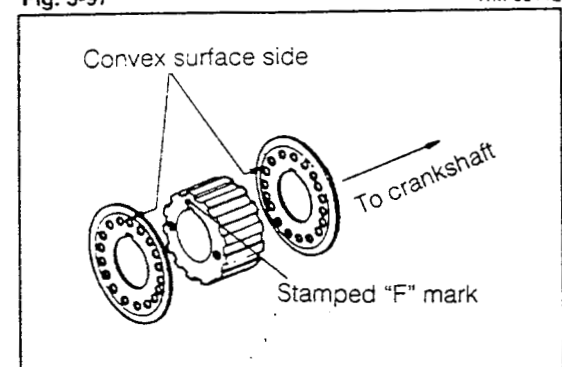
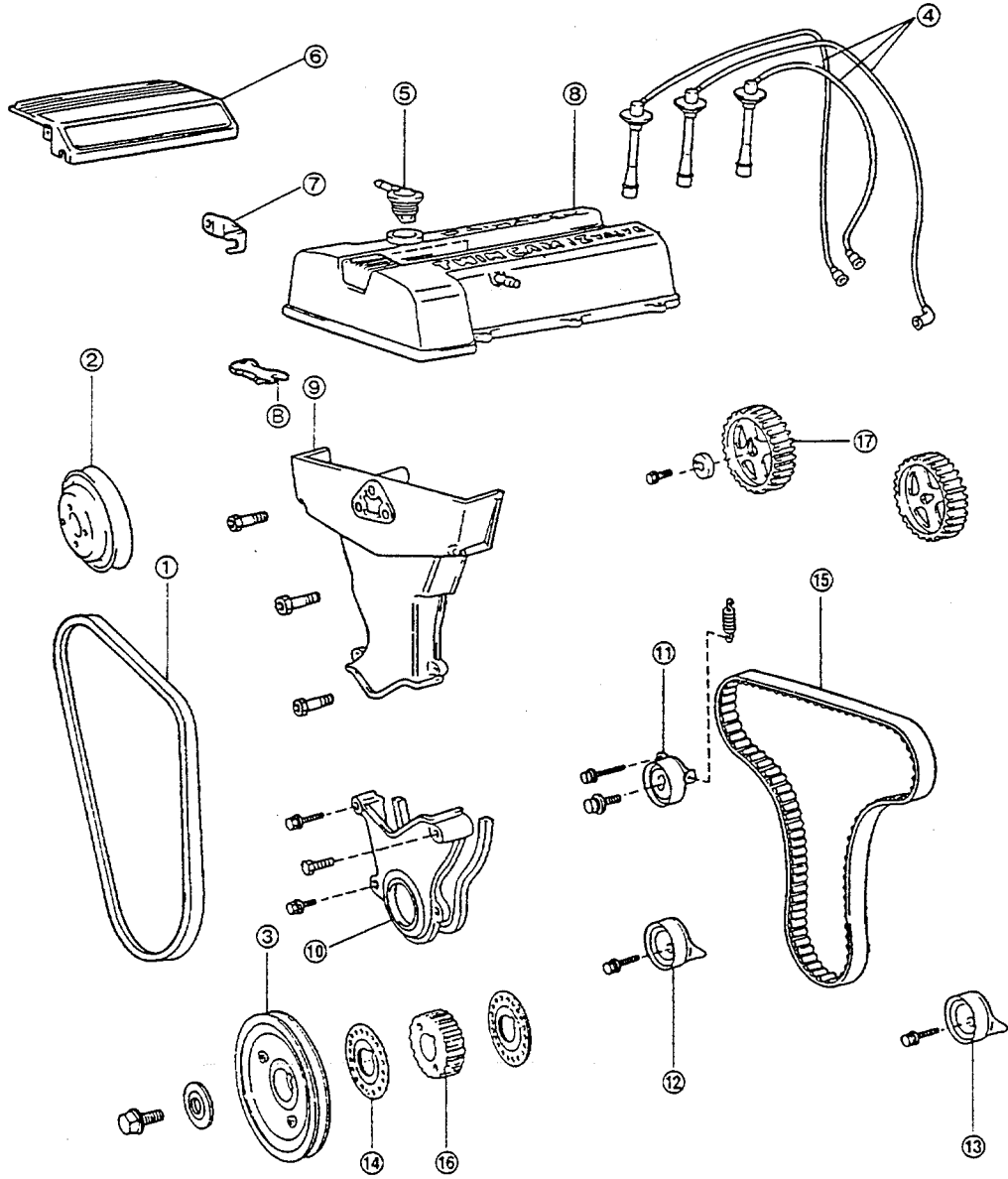

Fig. 5-98

WM-05113

ENGINE MECHANICALS

CB-80 ENGINE COMPONENTS OF TIMING BELT



- ① V-belt
- ② Water pump pulley
- ③ Crankshaft pulley
- ④ Resistive cords
- ⑤ Oil filler cap
- ⑥ Surge tank cover
- ⑦ Surge tank bracket
- ⑧ Cylinder head cover
- ⑨ Timing belt upper cover
- ⑩ Timing belt lower cover

- ⑪ Timing belt tensioner S/A
- ⑫ Timing belt idler S/A No.1
- ⑬ Timing belt idler S/A No.2
- ⑭ Crankshaft timing belt pulley flange
- ⑮ Timing belt
- ⑯ Crankshaft timing belt pulley
- ⑰ Crankshaft timing belt pulley (Intake & exhaust)

Fig. 5-99

WM-05114

REMOVAL

1. Remove the V-belt.
2. Remove the water pump pulley.
3. Remove the crankshaft pulley.

When removing the attaching bolt of the crankshaft pulley, use the following SST to prevent the ring gear from turning.

SST: 09201-87701-000

4. Remove the resistive cord.
 5. Remove the oil filler cap.
 6. Remove the surge tank cover.
 7. Remove the surge tank bracket.
 8. Remove the cylinder head cover.
 9. Remove the timing belt upper cover.
 10. Remove the timing belt lower cover.
 11. Remove the timing belt tensioner subassembly.
- When removing the timing belt tensioner subassembly, set the piston No.1 to the top dead center under the compression stroke.

(Before removing the timing belt tensioner, align the punch marks of the crankshaft and camshaft timing belt pulleys with the indicators, respectively.)

NOTE:

After the timing belt tensioner has been removed, under no circumstances should the camshaft or the crankshaft timing belt pulley be rotated. If they should be rotated, the piston will interfere with the valves, resulting in damage to these parts.

12. Remove the timing belt idler subassembly No.1.
13. Remove the timing belt idler subassembly No.2. Remove it, using a 10 mm hexagon wrench.

14. Remove the crankshaft timing belt pulley flange.
 15. Remove the timing belt.
- Prior to the timing belt removal, put a mark which shows the normal rotating direction at the back surface of the timing belt, using chalk or the like.

NOTE:

- ① While removing the timing belt, make sure not to bend the belt sharply to form a small radius. Moreover, never use a screwdriver or the like.
- ② Never allow oils and water to get to the timing belt.

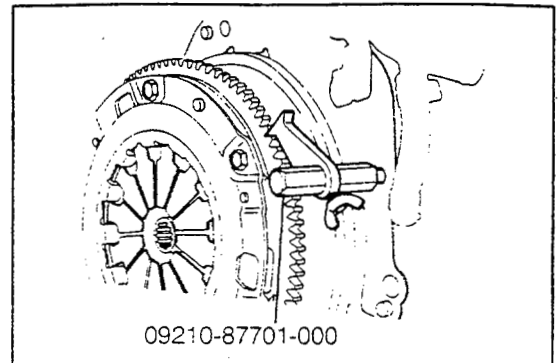

Fig. 5-100

WM-05115

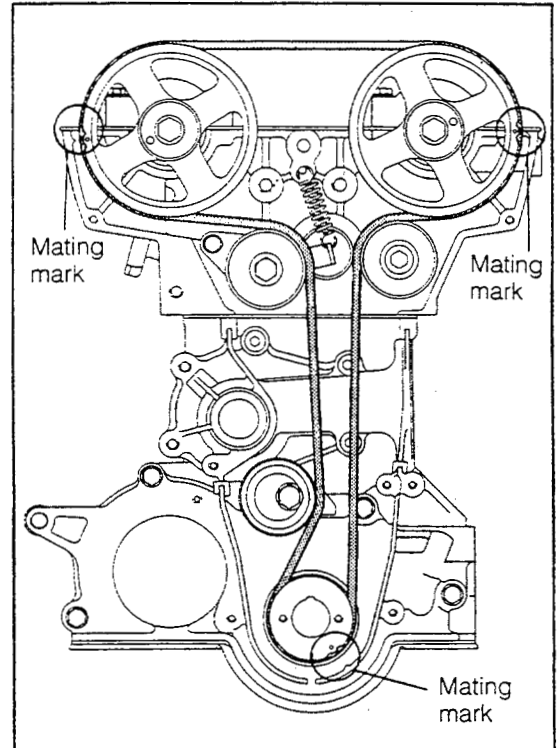

Fig. 5-101

WM-05116

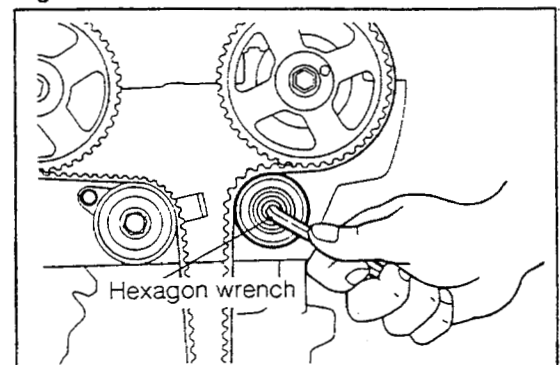

Fig. 5-102

WM-05117

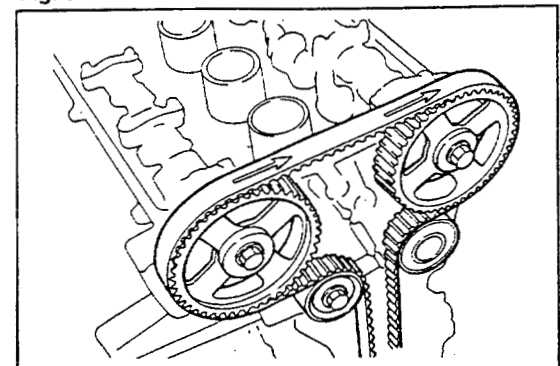

Fig. 5-103

WM-05118

ENGINE MECHANICALS

16. Remove the crankshaft timing belt pulley, as follows:
Screw in M6 bolts. Remove the crankshaft timing belt pulley together with the bolts.

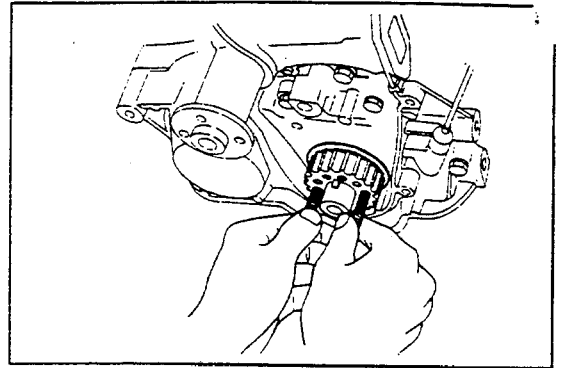

Fig. 5-104

WM-05119

17. Remove the camshaft timing belt pulley (intake & exhaust).

When removing the attaching bolt of the camshaft timing belt pulley, prevent the rotation of the camshaft by holding the hexagonal section (width across flats: 23 mm) of the cylinder No.1 with a spanner or the like.

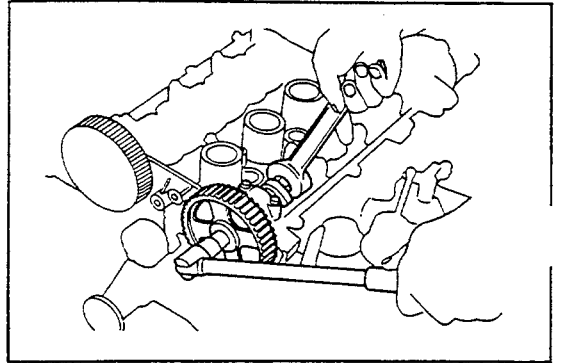

Fig. 5-105

WM-05120

INSPECTION

1. Checking of timing belt

Check each section of the timing belt. Replace the belt which exhibits the following damage.

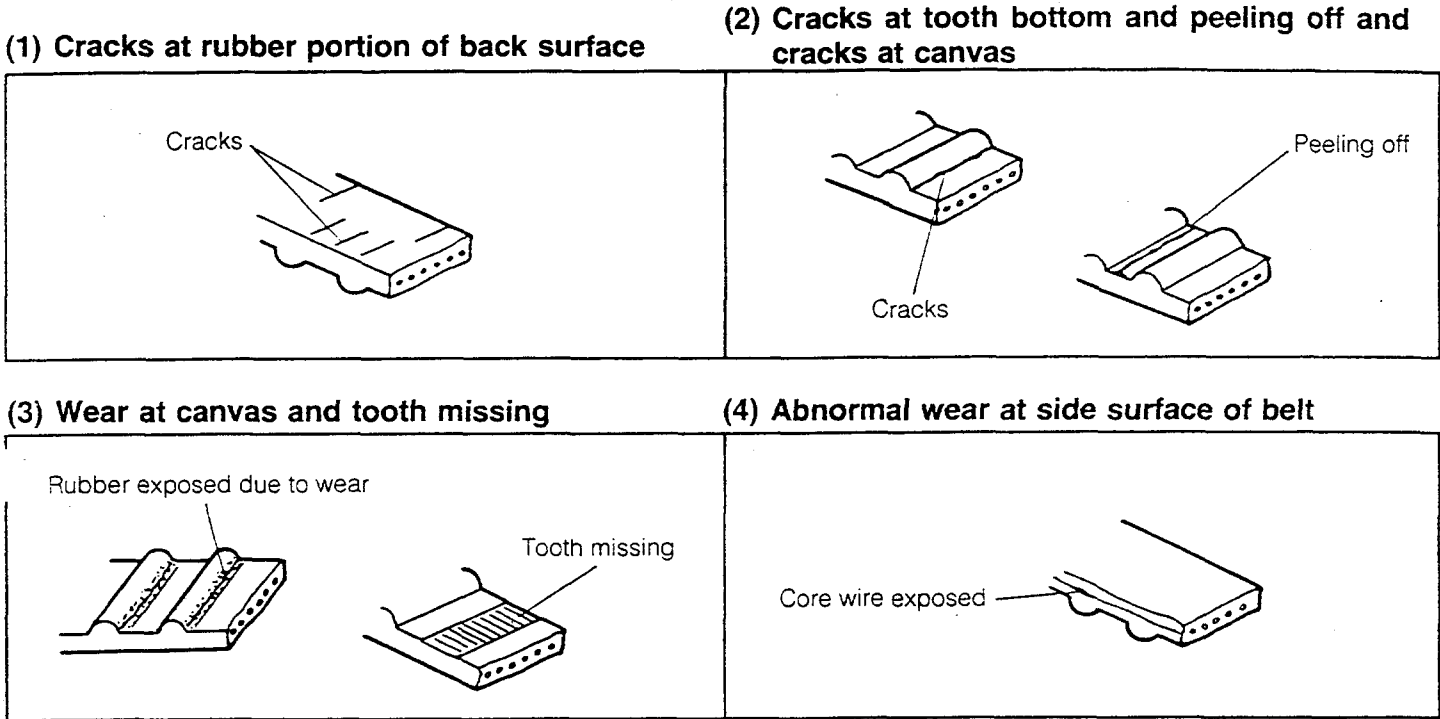

Replace the belt in the following cases, even if no external damage is observed.

- (1) Case where the timing belt has been continuously exposed to water owing to water leakage of the water pump, etc.
- (2) Case where the rubber may have swollen because of a large amount of oil stuck on the timing belt
- (3) Case where most likely excessive force has been applied to the timing belt due to a camshaft seizure

WM-05121

2. Checking of timing belt tensioner

Turn the tensioner. Check the bearing for a lock condition and abnormal noise. Also check the belt contact surface for damage.

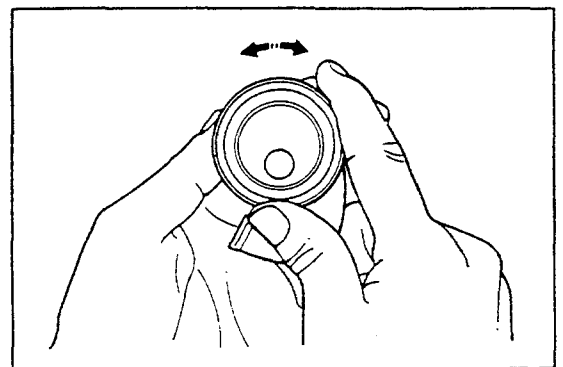

Fig. 5-106

WM-05122

3. Checking of timing belt idler subassemblies No.1 and No.2

Check the timing belt idler subassemblies No.1 and No.2 in the same way as with the timing belt tensioner.

WM-05123

ENGINE MECHANICALS

4. Checking of timing belt pulley
(1) Check the timing belt pulley for wear.

mm (inch)

	Minimum limit
Camshaft timing belt pulley	110.6 (4.354)
Crankshaft timing belt pulley	54.6 (2.149)

If wear of the timing belt pulley exceeds the minimum limit above, replace the timing belt pulley.

- (2) Check the belt contact surface of the timing belt pulley for scratches, etc.

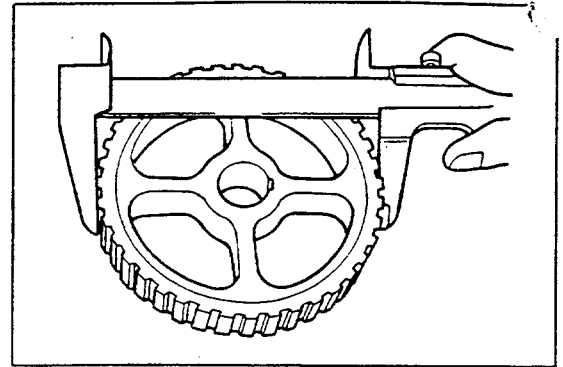

Fig. 5-107

WM-05124

5. Checking of crankshaft timing belt pulley flange
Check the crankshaft timing belt pulley flange for deformation or damage.

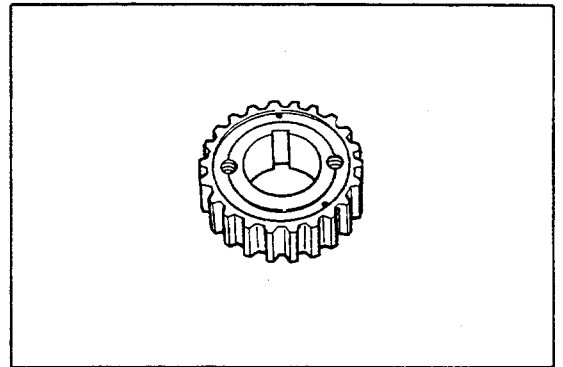

Fig. 5-108

WM-05125

STALLATION

1. Installation of camshaft timing belt pulley
 - (1) Install the camshaft timing belt pulley to the camshaft with the "F" mark facing toward your side.
 - (2) Install the washer plate of the timing belt pulley in such a way that the washer plate's locating pin for camshaft positioning use is aligned with the groove of the timing belt pulley and the hole at the end surface of the camshaft.
 - (3) Tighten the attaching bolt.

Tightening Torque: 3.0 - 4.5 kg-m (22 - 33 ft-lb)

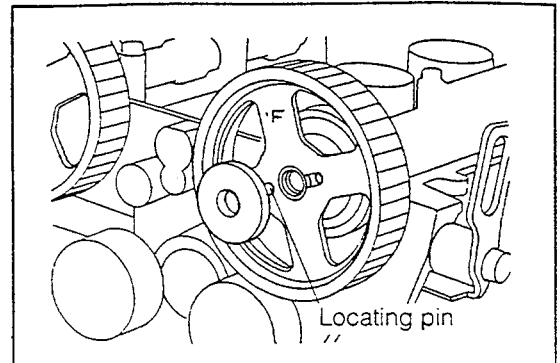

Fig. 5-109 WM-05126

Installation of crankshaft timing belt pulley flange
 Install the crankshaft timing belt pulley flange with its hemmed portion at the periphery facing the cylinder block side.

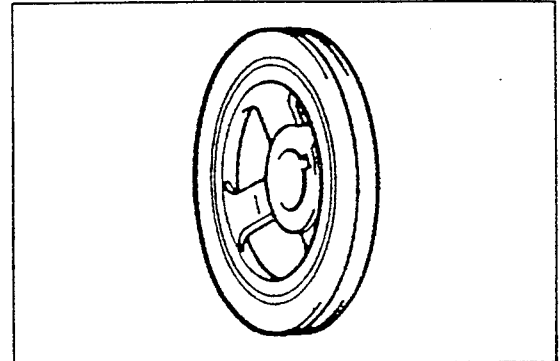

Fig. 5-110 WM-05127

3. Installation of crankshaft timing belt pulley
 With the "F" mark at the end surface of the crankshaft timing belt pulley facing toward your side, insert the pulley into the crankshaft, aligning with the key groove.

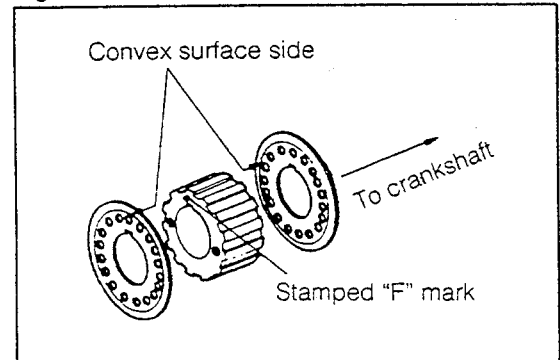

Fig. 5-111 WM-05128

4. Installation of timing belt idler subassembly No.1
 When installing the idler subassembly No.1, bring the right side of the locating bracket into contact with the balance shaft gear cover. Namely, set the bracket in such a way that a clearance is provided between the left side of the bracket and the balance gear cover.

Tightening Torque: 3.0 - 4.5 kg-m (22 - 33 ft-lb)

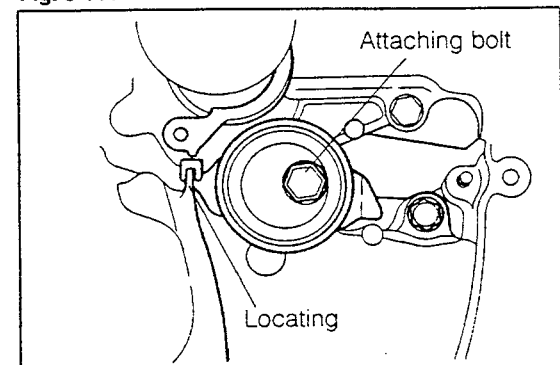

Fig. 5-112 WM-05129

5. Installation of timing belt idler subassembly No.2
 Install the timing belt idler subassembly No.2, using a 10 mm hexagon wrench.

Tightening Torque: 4.0 - 5.0 kg-m (29 - 36 ft-lb)

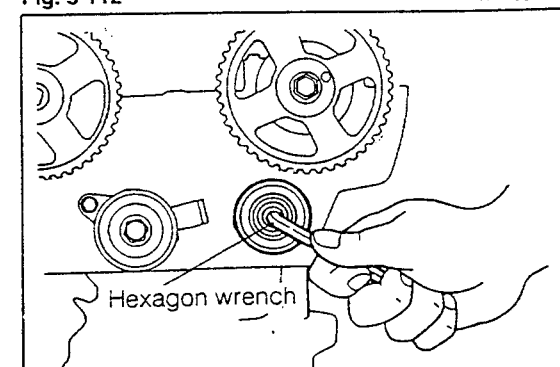

Fig. 5-113 WM-05130

ENGINE MECHANICALS

6. Installation of timing belt tensioner

- (1) With the timing belt tensioner set to the lowest position, temporarily tighten the two attaching bolts of the timing belt tensioner.

(This tightening must be made to such an extent that the tensioner can not be moved when the tension spring is attached.)

- (2) Install the tension spring. Ensure that the tension spring are positively hooked at its both ends and will not be detached.

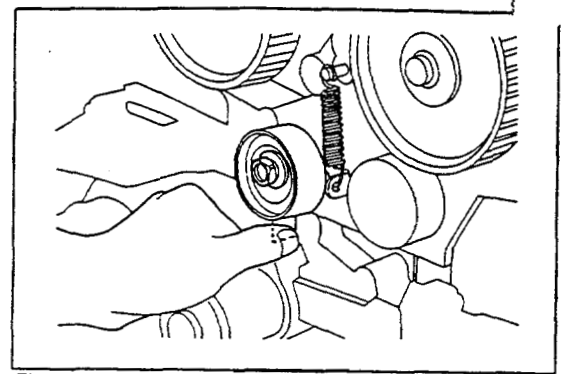

Fig. 5-114

WM-05131

7. Install the timing belt.

NOTE:

- ① Make sure not to bend the belt sharply to form a small radius. Such practice will cut the belt cord. (Never try to pry the timing belt with a screwdriver or the like.)
- ② Never permit oils or water to get to the belt.
- ③ When turning the engine with the belt installed, the rotation should be made at the crankshaft side.
- ④ If the belt is reused, install the belt in such a way that the belt is turned in the same direction indicated by the arrow mark which was put at the belt's back surface during the belt removal.

WM-05132

- (1) Ensure that the recessed marks of the crankshaft and camshaft timing belt pulleys are aligned with the indicator marks, respectively.

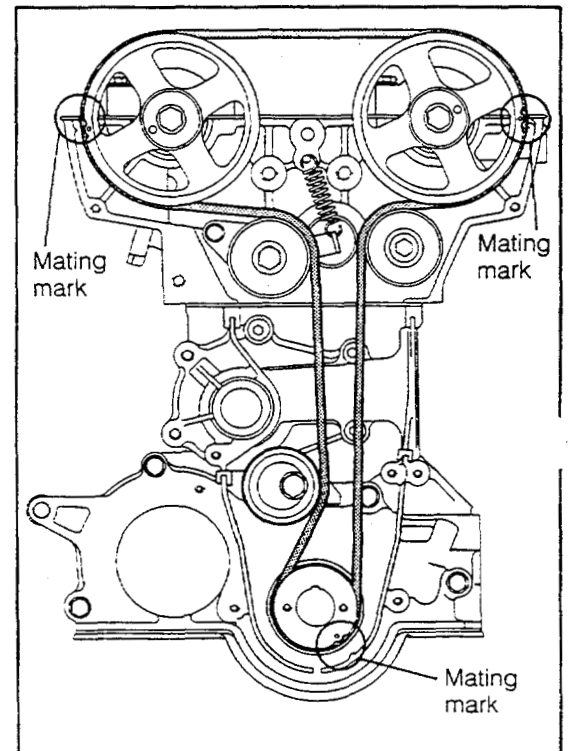

Fig. 5-115

WM-05133

- (2) Install the timing belt in such a way that the part number of the timing belt can be seen properly, as viewed toward the cylinder head side, and comes between the timing marks of the camshaft pulley. Also, make sure that the three mating marks at the back surface of the belt are aligned with the recessed marks on the camshaft and crankshaft timing belt pulleys, respectively. Ensure that the belt is not slackened, especially at the tension side (exhaust side) of the belt.

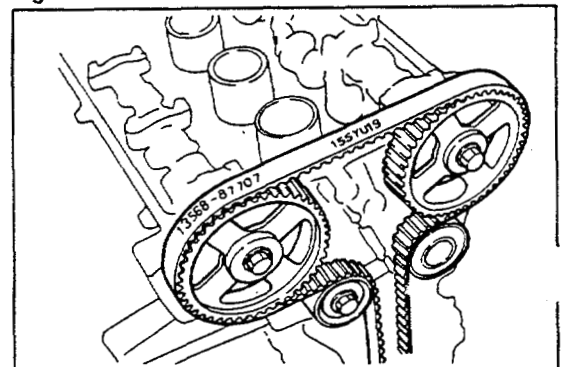

Fig. 5-116

WM-05134

- (3) Ensure that the mating marks on the belt are aligned with those of the timing belt pulleys, respectively.
- (4) Slacken the attaching bolts of the tensioner which were tightened temporarily in the previous step. Ensure that the timing belt tension is provided by the tension spring.

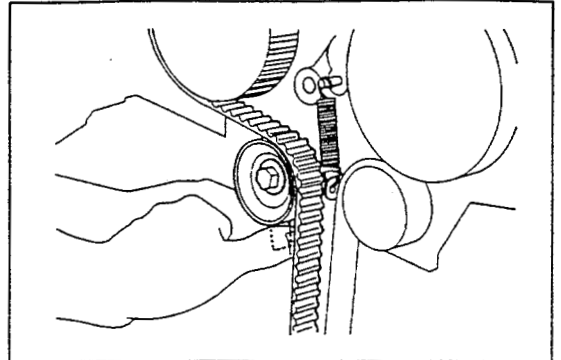

Fig. 5-117

WM-05135

- (5) Turn the crankshaft slightly in the normal rotating direction (clockwise), thus applying tension to the timing belt between the intake camshaft timing belt pulley and the exhaust camshaft timing belt pulley and between the exhaust camshaft timing belt pulley and the crankshaft timing belt pulley.

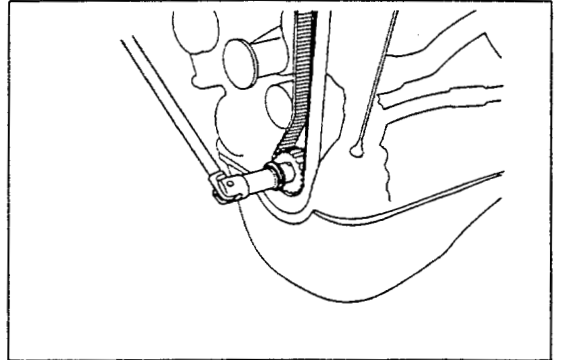

Fig. 5-118

WM-05136

- (6) Turn the crankshaft about two turns in the normal rotating direction, until the mating mark on the cylinder head is aligned with the recessed timing mark on the camshaft.

NOTE:

Never make a reverse turn, even if it is the slightest one, during this operation.

WM-05137

- (7) Ensure that the tension spring force is being applied to the tensioner, by slackening the bolts of the timing belt tensioner.
- (8) Tighten the bolts of the timing belt tensioner.

Tightening Torque:

M10 bolt 3.0 - 4.5 kg-m (22 - 33 ft-lb)

M6 bolt 0.6 - 0.9 kg-m (4.5 - 6.5 ft-lb)

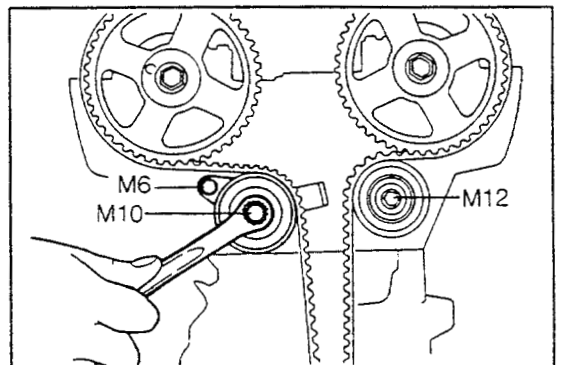

Fig. 5-119

WM-05138

- (9) Push the belt between the camshaft timing belt pulleys by hand. Ensure that the deflection meets the specification.

Specified Deflection: About 5 mm (0.197 inch)

(with a force of 3 kg (6.6 lb) applied)

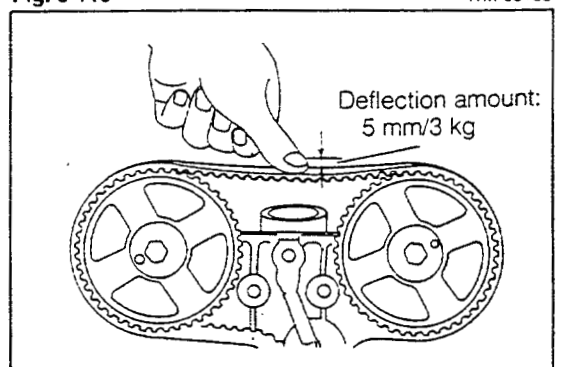

Fig. 5-120

WM-04138A

ENGINE MECHANICALS

NOTE:

Be sure to tighten the timing belt tensioner with the bolts, until it no longer can be moved.

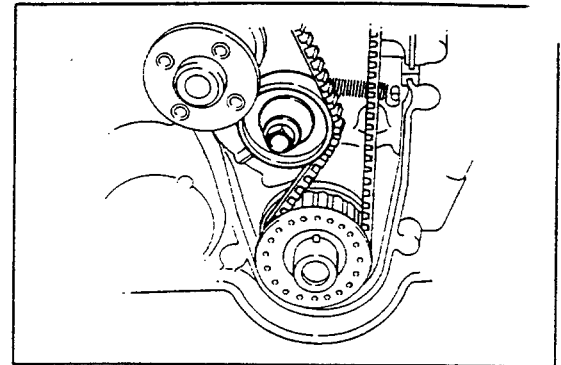

Fig. 5-121

WM-05139

8. Installation of crankshaft timing belt pulley flange
Install the crankshaft timing belt pulley flange with its hemmed portion at the periphery facing the outside.

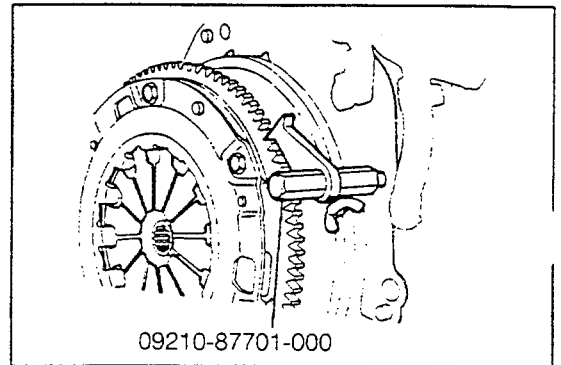

Fig. 5-122

WM-05140

9. Install the timing belt lower cover.
10. Install the timing belt upper cover.
11. Install the cylinder head cover.
12. Install the surge tank bracket.
13. Install the surge tank cover.
14. Install the oil filler cap.
15. Install the resistive cords.
16. Install the crankshaft pulley.

Tightening Torque: 9.0 - 10.0 kg-m (65 - 72 ft-lb)

NOTE:

When tightening the crankshaft pulley, use the following SST so as not to apply any excessive force to the timing belt.

SST: 09210-87701-000

17. Install the water pump pulley.
18. Install the V-belt.
19. SST removal

Remove the engine assembly from the following SSTs.

SST: 09219-87202-000

WM-05141

CYLINDER HEAD

CB-23 AND CB-61 ENGINES COMPONENTS OF CYLINDER HEAD

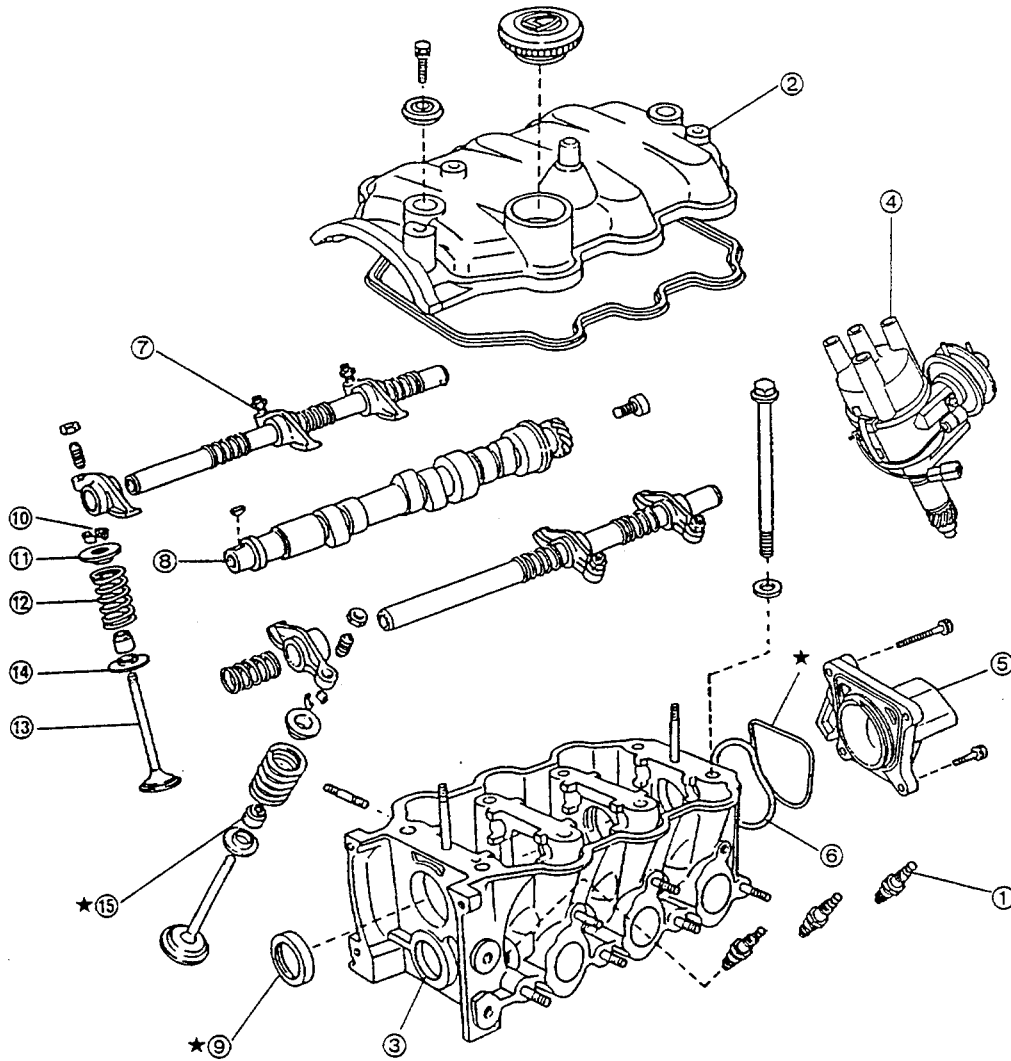

* : Non-reusable parts

- ① Spark plug
- ② Cylinder head cover
- ③ Cylinder head Ay
- ④ Distributor
- ⑤ Distributor housing
- ⑥ Wave washer
- ⑦ Valve rocker shaft
Valve rocker arm
Compression spring (Valve rocker shaft)

- ⑧ Camshaft
- ⑨ Oil seal
- ⑩ Valve spring retainer lock
- ⑪ Valve spring retainer
- ⑫ Compression spring (for valve)
- ⑬ Valve
- ⑭ Valve spring seat
- ⑮ Valve stem oil seal

Fig. 5-123

ENGINE MECHANICALS

REMOVAL

1. Remove the spark plugs.
2. Remove the cylinder head cover.
3. Remove the distributor.
4. Remove the distributor housing.
5. Remove the wave washer.
6. Remove the cylinder head assembly.
 - (1) Loosen the cylinder head bolts gradually over two or three stages, following the specified numerical sequence.

- (2) Remove the cylinder head. Attach the cylinder head to the SST. Fit the SST in a vise securely.
SST: 09219-87703-000

NOTE:

Be very careful not to scratch the gasket surface of the cylinder head.

7. Removal of valve rocker shafts, valve rocker arms and compression springs (for shafts)
Slacken all adjusting screws of the valve rocker arm. Pull out the valve rocker shaft, using the following SST.
SST: 09204-87701-000

NOTE:

Perform this operation while holding the compression spring by hand so as to prevent it from jumping out. Arrange the removed parts in order so that their installation positions may be known readily.

8. Removal of camshaft
Pull out the camshaft toward the rear side of the cylinder head.
Utmost care must be exercised not to damage the camshaft bearing bores of the cylinder head during this operation.

9. Removal of oil seal
Remove the oil seal, using a screwdriver or the like.
NOTE:
The oil seal is a nonreusable part.

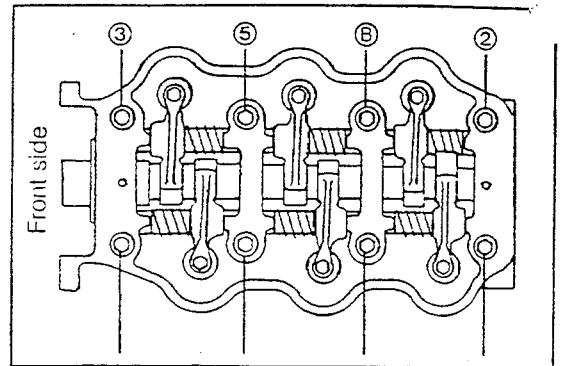

Fig. 5-124

WM-05143

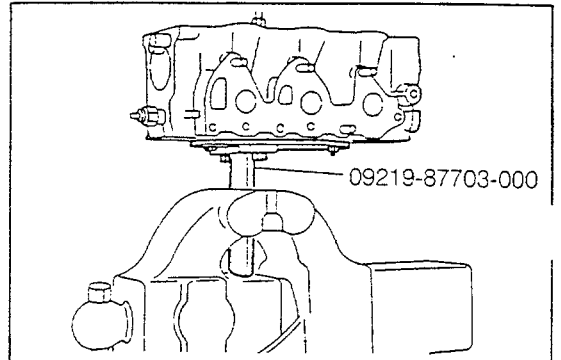

Fig. 5-125

WM-05144

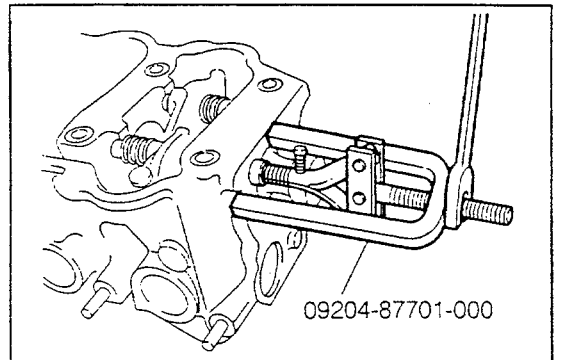

Fig. 5-126

WM-05145

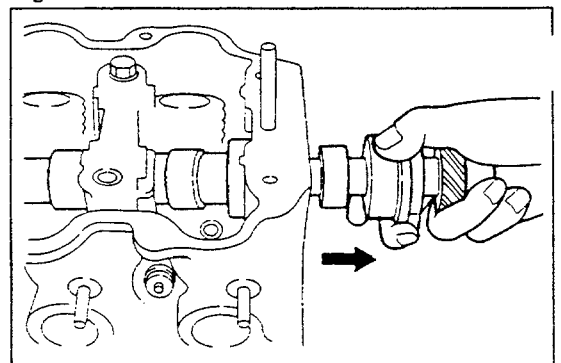

Fig. 5-127

WM-05146

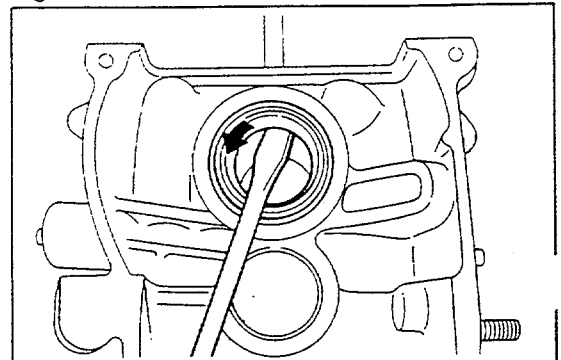

Fig. 5-128

WM-05147

1. Removal of valve spring retainer locks
Insert the valve rocker shaft. Compress the valve spring with the SST. Remove the spring retainer locks.
SST: 09202-87702-000

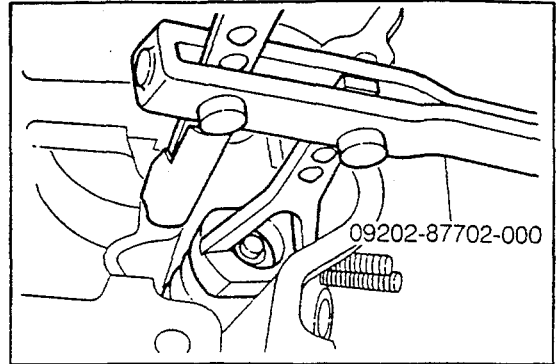

Fig. 5-129

WM-05148

NOTE:

As for those parts 11 through 14 given below, group the parts by the kinds of valves or cylinders so that the installation positions of the parts may be known readily.

11. Remove the valve spring retainers.
12. Remove the compression springs.
Remove the valves.
13. Remove the valve stem oil seals.
15. Remove the valve spring seats.

NOTE:

Wash the removed parts with a cleaning solvent and blow them by compressed air.
Do not use a cloth or the like to wipe the parts.
Remove the cylinder head from the SST.

WM-05149

INSPECTION

1. Checking of cylinder head
 - (1) Check the cylinder head for cracks, damage and distortion.
If the cylinder head exhibits cracks or damage, replace it, as required.
Check the cylinder head for distortion on the following three surfaces.
 - ① Distortion of cylinder block gasket surface
Maximum Limit: 0.10 mm (0.039 inch)

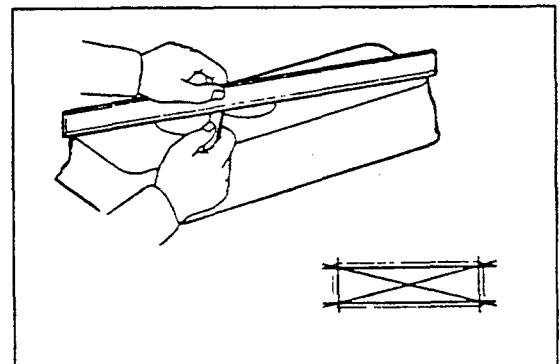

Fig. 5-130

WM-05150

CB-61 and CB-80 engines:

If the distortion of the cylinder block gasket surface exceeds the maximum limit, replace the cylinder head.

CB-23 engine:

If the distortion of the cylinder block gasket surface exceeds the maximum limit, correct the surface, making sure not to exceed the height limit of 125.7 mm (4.949 inches).

ENGINE MECHANICALS

- ② Distortion of intake manifold attaching surface
Maximum Limit: 0.1 mm (0.039 inch)
- ③ Distortion of exhaust manifold attaching surface
Maximum Limit: 0.1 mm (0.039 inch)

CB-23 and CB-61 engines:

If the distortion of the intake manifold or exhaust manifold attaching surface exceeds the maximum limit, correct the surface, making sure not to exceed the width limit of 159.4 mm (6.28 inches).

(2) Checking valve seats

Apply a thin film of red lead to the valve seat. Let the valve drop by its own weight onto the valve seat two or three times. Take out the valve. Measure the width of the contact surface of the valve seat.

Specified Value: 1.0 - 1.8 mm (0.039 - 0.071 inch)

NOTE:

If the valve-to-valve seat contact surface does not conform to the specifications or the contact surface exhibits roughness, correct the cylinder head or replace it, as required.

(3) Refacing valve seats

Reface the valves, using a valve seat cutter.

NOTE:

If the valve guide bush is worn, first replace it. Then, proceed to the valve seat refacing.

• Refacing procedure for intake valve seats

- ① Recondition the roughness on the valve-to-valve seat contact surface, using a 45-degree cutter.
- ② Using a 30-degree cutter, cut the valve seat in such a way that the circumference of the surface refaced by the 45-degree cutter may become 35 ± 0.1 mm (1.38 ± 0.004 inches).

- ③ Using a 70-degree cutter, cut the valve seat in such a way that the width of the surface refaced by the 45-degree cutter may become 1.4 mm (0.055 inches).

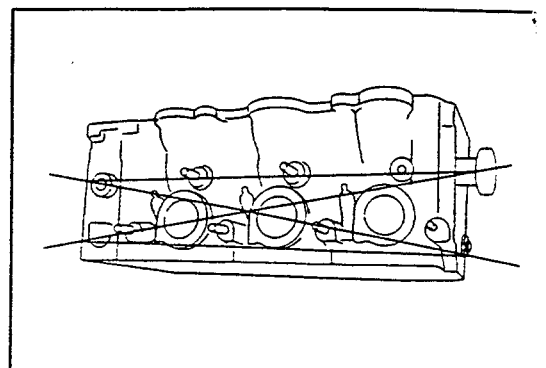

Fig. 5-131

WM-05150A

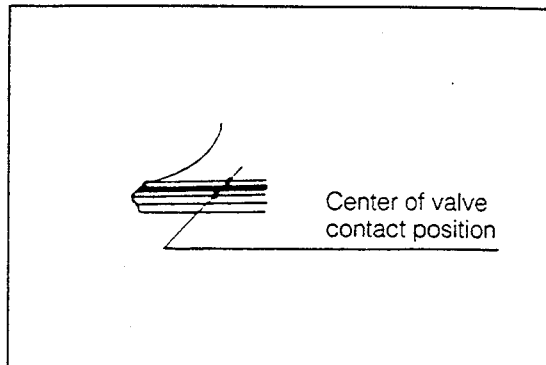

Fig. 5-132

WM-05151

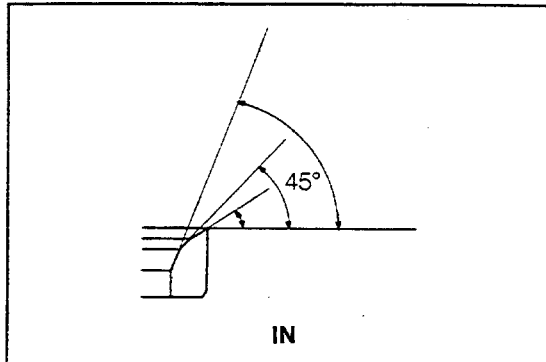

Fig. 5-133

WM-05152

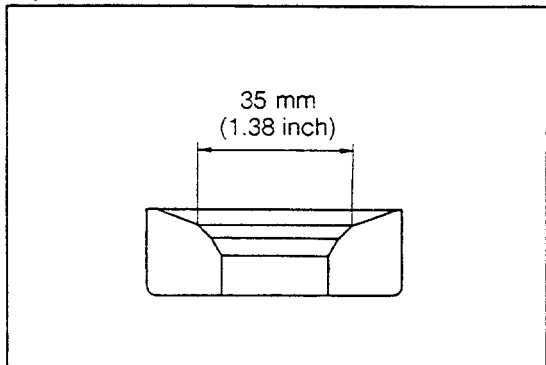

Fig. 5-134

WM-05153

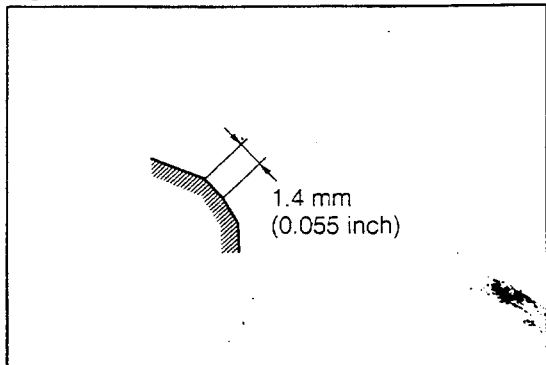

Fig. 5-135

WM-05154

- ④ Using the 45-degree cutter, remove burrs produced during the refacing by the 30-degree and 70-degree cutters.

• Refacing procedure for exhaust valve seats

- ① Recondition the roughness on the valve-to-valve seat contact surface, using a 45-degree cutter.

- ② Using a 20-degree cutter, cut the valve seat in such a way that the circumference of the surface refaced by the 45-degree cutter may become 32 mm (1.26 inches).

- ③ Using a 60-degree cutter, cut the valve seat in such a way that the width of the surface refaced by the 45-degree cutter may become 1.4 mm (0.055 inches).

- ④ Using the 45-degree cutter, remove burrs produced during the refacing by the 20-degree and 60-degree cutters.

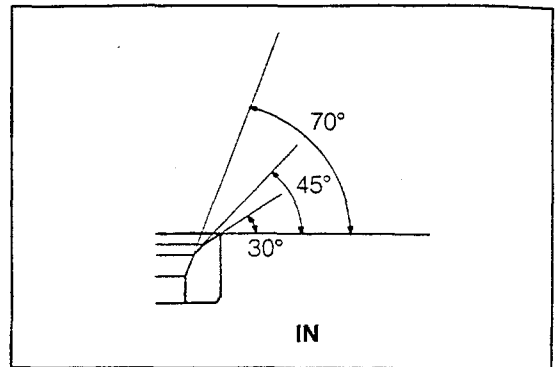

Fig. 5-136

WM-05155

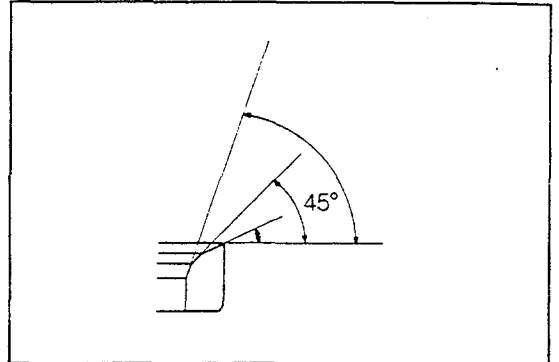

Fig. 5-137

WM-05156

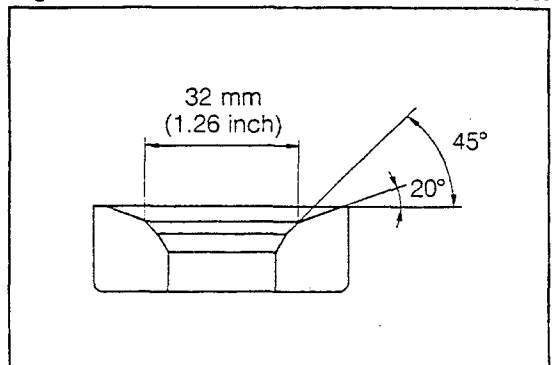

Fig. 5-138

WM-05157

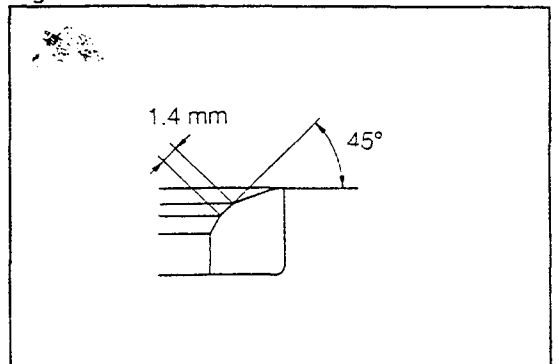

Fig. 5-139

WM-05158

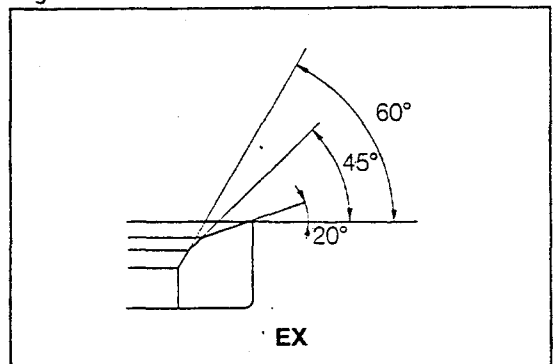

Fig. 5-140

WM-05159

ENGINE MECHANICALS

(4) Checking of valve recession

After the valve seat has been refaced, install the new valve. Measure the distance between the cylinder attaching surface of the cylinder head (attaching surface of the cylinder head gasket) and the uppermost section of the valve. Ensure that the distance does not exceed the following maximum limit.

Maximum Limit:

Intake valve 1.886 mm (0.0743 inch)

Exhaust valve 2.807 mm (0.1105 inch)

NOTE:

If the recession exceeds the maximum limit, replace the cylinder head.

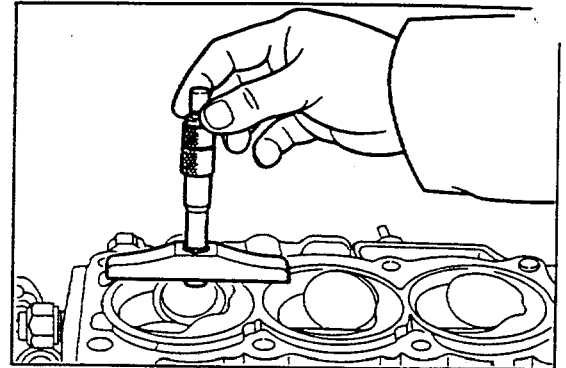

Fig. 5-141

WM-05160

2. Checking of valves

(1) Checking valve stems

Visually inspect the valve stem for seizure or damage. If the valve exhibits damage, replace it together with the valve guide bush as a set.

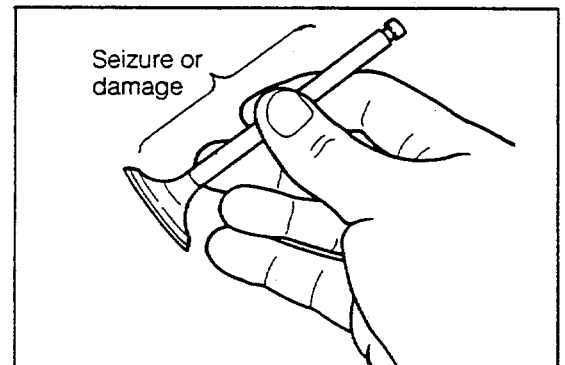

Fig. 5-142

WM-05161

(2) Checking valve stem end

① Check the valve stem end for abnormal wear.

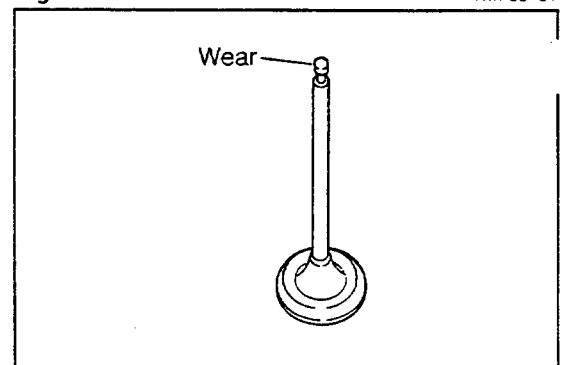

Fig. 5-143

WM-05162

② If the valve stem exhibits abnormal wear, correct the stem end with a valve refacer. However, make sure that the valve has the minimum valve overall length of 100.85 mm (3.97 inches).

Minimum Valve Overall Length:

100.85 mm (3.97 inches)

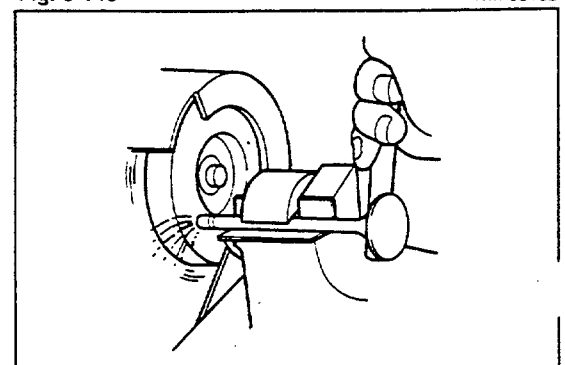

Fig. 5-144

WM-05163

(3) Checking of valve heads

① Check the valve-to-valve seat contact surface for roughness or damage. Remove any carbon deposit from the valve head.

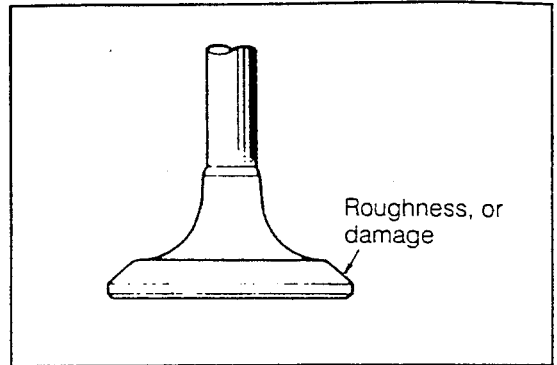

Fig. 5-145

WM-05164

② If the valve-to-valve seat contact surface exhibits any damage, grind the surface with a valve refacer.

Valve Face Angle: 45.5°

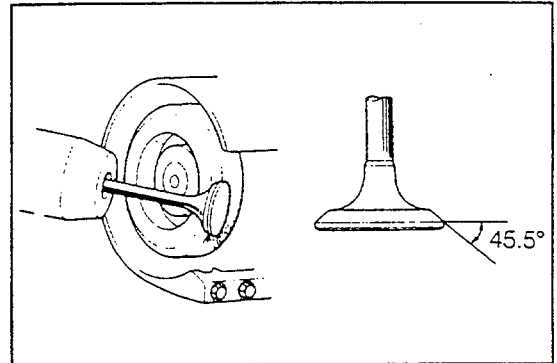

Fig. 5-146

WM-05165

③ After the valve head has been ground, measure the stock thickness of the valve head.

Minimum Limit

Intake valve	0.8 mm (0.031 inch)
Exhaust valve	1.0 mm (0.039 inch)

NOTE:

If the stock thickness of the valve head is less than the limit, replace it with a new one.

When replacing the valve with new one be sure to check the oil clearance with the valve guide bush.

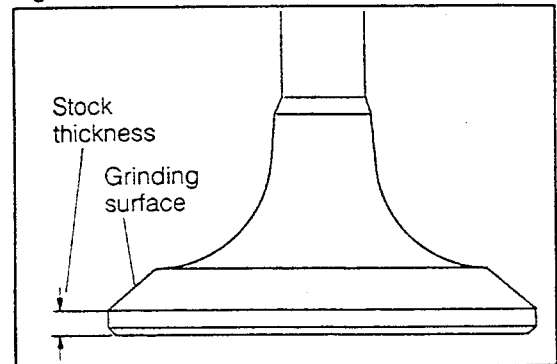

Fig. 5-147

WM-05166

3. Checking of valve guide bush-to-valve stem oil clearance

(1) Measuring oil clearance

Measure the valve guide bush-to-valve stem oil clearance.

Oil clearance = Inner diameter of valve guide bush – Outer diameter of valve stem

Specified Value: Intake valve: 0.040 - 0.090 mm (0.0016 - 0.0035 inch)

Exhaust valve: 0.045 - 0.100 mm (0.0018 - 0.0039 inch)

NOTE:

If the measured oil clearance exceeds the specified value, replace the valve guide bush together with the valve as a set.

WM-05167

ENGINE MECHANICALS

- ① Measurement of inner diameter of valve guide bush
Perform the measurement at six points.

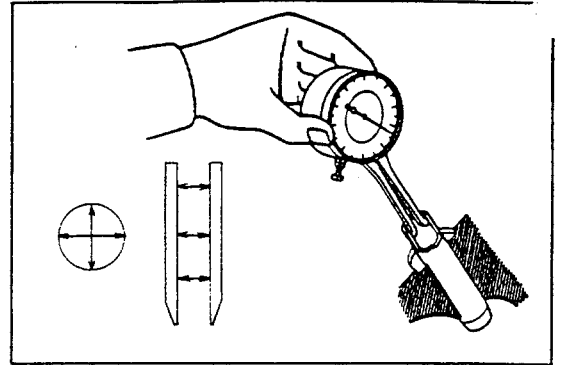

Fig. 5-148

WM-05168

- ② Measurement of outer diameter of valve stem
Perform the measurement at six points.

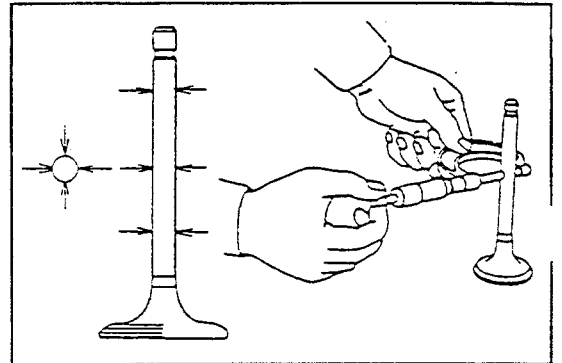

Fig. 5-149

WM-05169

(2) Replacing valve guide bush

NOTE:

When replacing the valve guide bush, replace also the valve as a set. However, if the bushes with rings (replacement part) have been already installed as valve guide bushes, replace the cylinder head.

WM-05170

• Exhaust side

- ① Break the valve guide bush, using a brass bar.

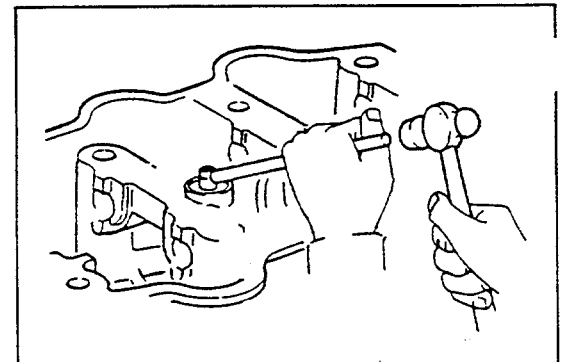

Fig. 5-150

WM-05171

- ② Drive out the valve guide bush toward the combustion chamber side, using the following SST.

SST: 09201-87201-000

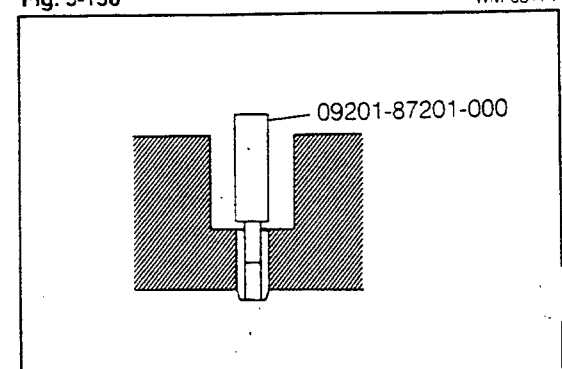

Fig. 5-151

WM-05172

- ③ Drive a new valve guide bush into position, until the snap ring contacts the cylinder head, using the following SST.

SST: 09201-87201-000

NOTE:

After the valve guide bush has been driven into position, remove any burr or the like, using an adjustable reamer. At this time, make sure that the specified oil clearance is assured between the valve guide bush and the valve stem.

• **Intake side**

- ① Drive out the valve guide bush from the combustion chamber side, using the following SST.

SST: 09201-87201-000

- ② Drive a new valve guide bush into position, until the snap ring contacts the cylinder head, using the following SST.

SST: 09201-87201-000

NOTE:

After the valve guide bush has been driven into position, remove any burr or the like, using an adjustable reamer. At this time, make sure that the specified oil clearance is assured between the valve guide bush and the valve stem.

4. Checking of valve springs

- (1) Check the valve spring for squareness, using a square.

Maximum limit: 1.5 mm (0.059 inch)

- (2) Using a spring tester, measure the free length. Also, measure the spring tension with the spring compressed to the specified installed length.

Minimum free length: 42.0 mm (1.654 inch)

Spring tension:

Minimum limit/installation height

22.7 kg/34.9 mm (56.7 lb/1.374 inch)

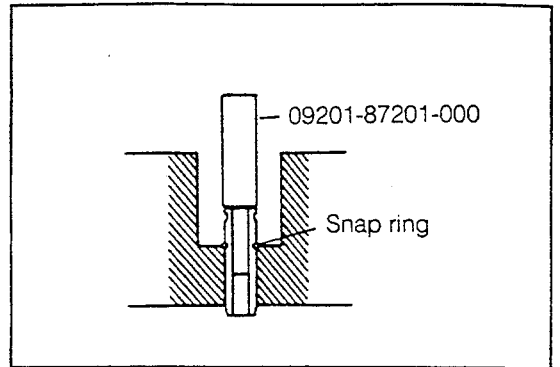

Fig. 5-152

WM-05173

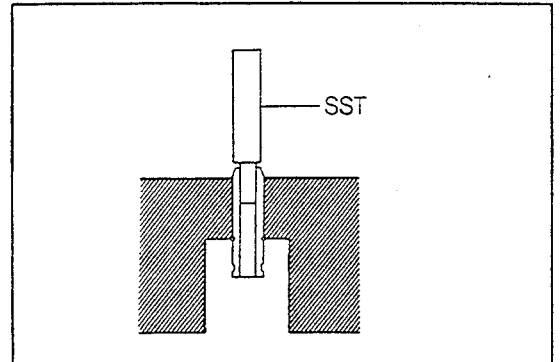

Fig. 5-153

WM-05174

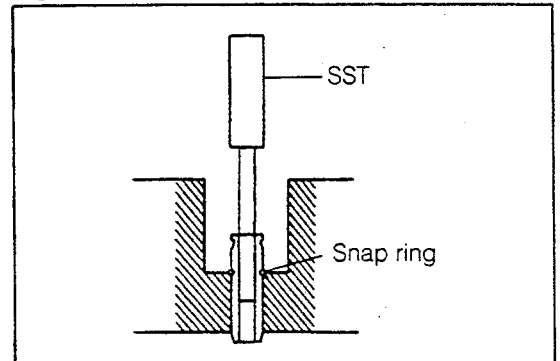

Fig. 5-154

WM-05175

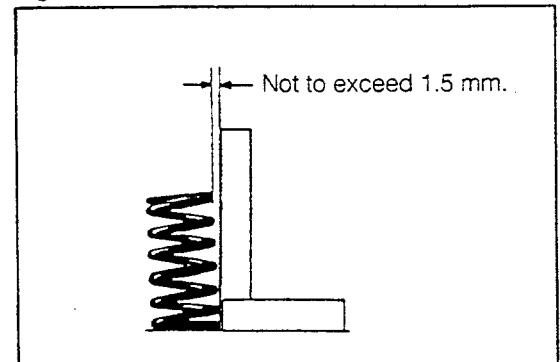

Fig. 5-155

WM-05176

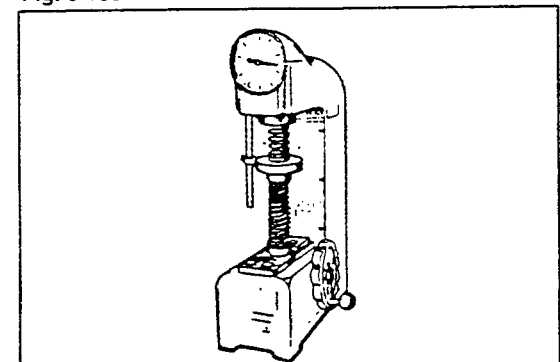

Fig. 5-156

WM-05177

ENGINE MECHANICALS

5. Checking of valve rocker arms and valve rocker shafts
(1) Check the rocker arms and rocker shafts for cracks and damage.

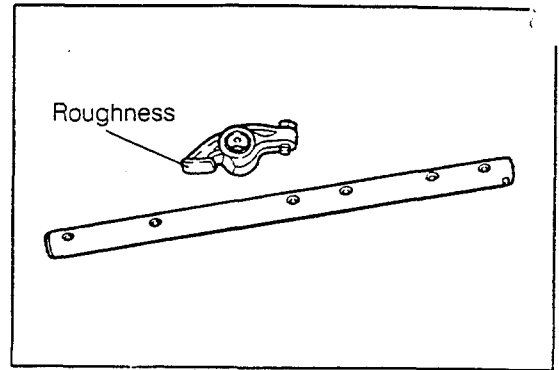

Fig. 5-157

WM-05178

- (2) Measure the oil clearance.

Oil clearance = Inner diameter of valve rocker arm –
Outer diameter of valve rocker shaft
Specified Value: Oil clearance 0.016 - 0.09 mm
(0.00063 - 0.00350 inch)

NOTE:

The oil clearance should be established by measuring the following two values: The inner diameter of each valve rocker arm and the outer diameter of the valve rocker arm installation section of the valve rocker shaft.

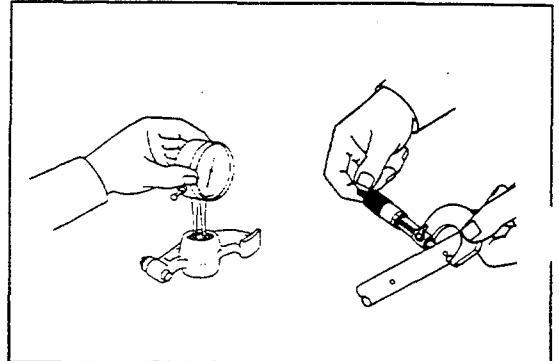

Fig. 5-158

WM-05179

If the oil clearance does not meet the specifications, replace the parts with new ones, as required, referring to the specified values of the inner diameter of the valve rocker arm and the outer diameter of the valve rocker shaft.

Inner diameter of valve rocker arm (new one)
16.000 - 16.018 mm (0.6300 - 0.6306 inch)
Outer diameter of valve rocker shaft (new one)
15.958 - 15.984 mm (0.6283 - 0.6293 inch)

[Reference]

Oil clearance at the time when the valve rocker shaft and valve rocker arm have been replaced by new ones:
0.016 - 0.060 mm (0.0006 - 0.0024 inch)

WM-05

Checking of camshaft

(1) Checking distributor drive gear

Check the distributor drive gear for cracks and abnormal wear.

NOTE:

If the distributor drive gear exhibits any abnormal wear, check the distributor driven gear, too.

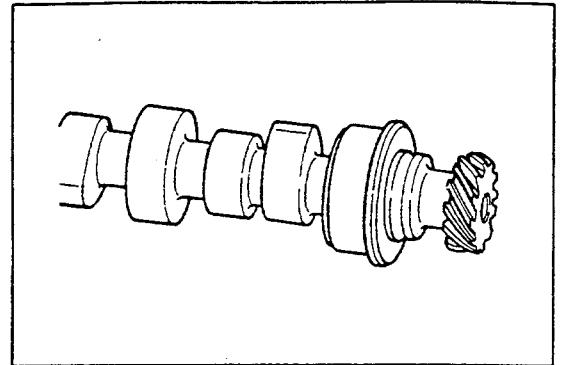

Fig. 5-159

WM-05181

(2) Checking camshaft for runout

Support the camshaft at its both ends with V-shaped blocks. Set a dial gauge to the mid-point of the center journal section of the camshaft. Turn the camshaft one turn, making sure that the camshaft will not move in the axial direction. Take a reading on the dial gauge during the turning. Calculate the maximum runout, i.e. the difference between the maximum and minimum readings.

Maximum runout: 0.03 mm (0.0012 inch)

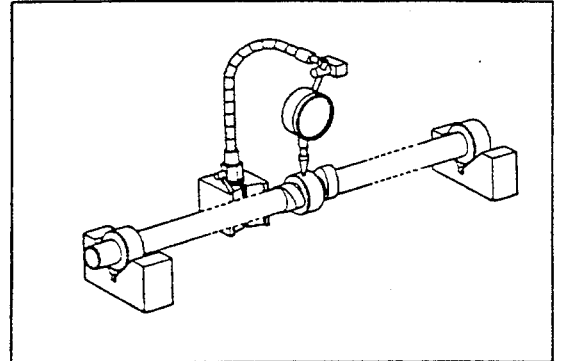

Fig. 5-160

WM-05182

(3) Checking cam lobe height

Minimum limit mm (inches)

CB-23	39.8 (1.567)
CB-61	39.8 (1.567)

If the measured height is less than the minimum limit, replace the camshaft.

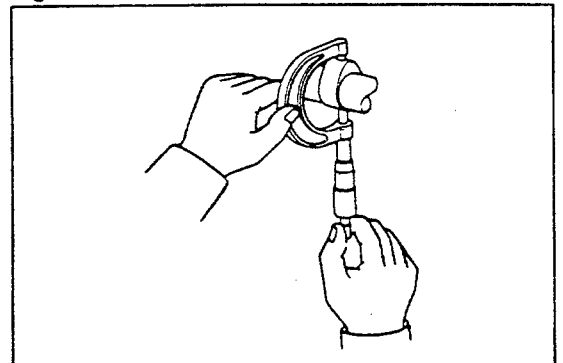

Fig. 5-161

WM-05183

ENGINE MECHANICALS

(4) Checking oil clearance

- ① Measure the outer diameters of the journal sections of the camshaft.
- ② Measure the inner diameters of the bearing bores of the cylinder head at three points of front, center and rear sections. This bore measurement for each section should be conducted in two directions, 90 degrees apart from each other.

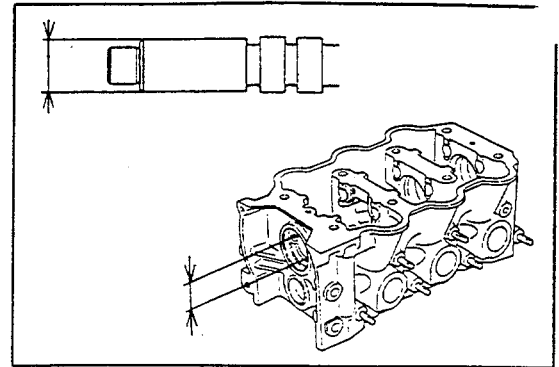

Fig. 5-162

WM-05184

Oil clearance

Front	0.04 - 0.14 mm (0.0016 - 0.0055 inch)
Center	0.09 - 0.19 mm (0.0035 - 0.0075 inch)
Rear	0.06 - 0.16 mm (0.0024 - 0.0063 inch)

If the oil clearance exceeds the specified value, replace the parts, as required, so that the oil clearance may meet the specifications, referring to the following specified dimensions of the camshaft journal sections and the camshaft bearing bores of the cylinder head.

WM-05185

Specified Dimensions

	Front	Center	Rear
Outer diameter of camshaft journal section	31.960 - 31.980 mm (1.2583 - 1.2591 inches)	47.385 - 47.410 mm (1.8655 - 1.8665 inches)	48.415 - 48.440 mm (1.9061 - 1.9071 inches)
Inner diameter of camshaft bearing bore of cylinder head	32.020 - 32.045 mm (1.2606 - 1.2616 inches)	47.500 - 47.525 mm (1.8701 - 1.8711 inches)	48.500 - 48.525 mm (1.9094 - 1.9104 inches)

WM-05186

7. Checking of wave washer

Check the wave washer for flattened condition or damage.

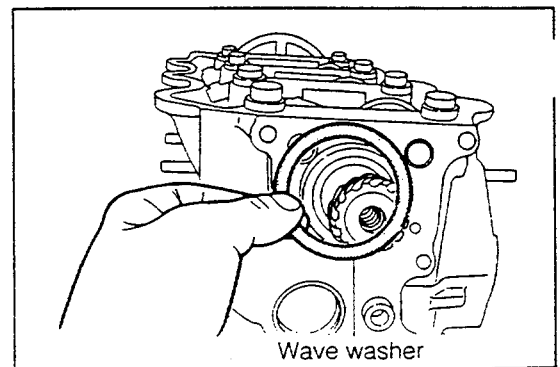

Fig. 5-163

WM-05187

8. Hand lapping of valves

- (1) After all checks have been completed, carry out hand lapping of the valves before assembling them.
- (2) Apply a thin film of abrasive compound to the valve and valve seat. Perform the lapping with a valve lapper.
- (3) After completion of the lapping, wash the valves and cylinder head, using a cleaning solvent. Blow them with compressed air.

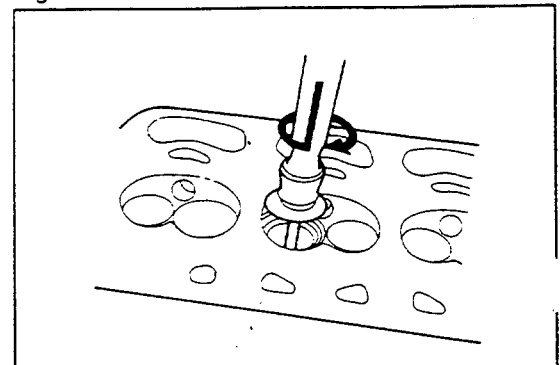

Fig. 5-164

WM-05188

STALLATION

Install the cylinder head to the SST (09219-87703-000).

1. Install the valve spring seats.
2. Installation of valve stem oil seals
Apply engine oil to a new valve stem oil seal. Then, insert it into the valve guide bush, using the following SST.
SST: 09201-87703-000

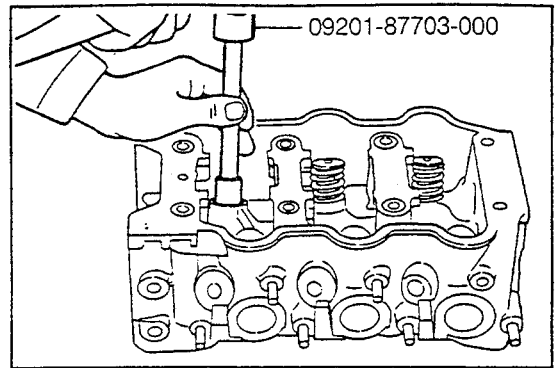

Fig. 5-165

WM-05189

3. Installation of valves
Apply engine oil to the valve stem. Insert it into the valve guide bush from the combustion chamber side, being very careful not to damage the valve stem oil seal.

NOTE:

Once the valve has been inserted, never pull it out from position. If the valve should be pulled out, replace the valve stem oil seal with a new one.

WM-05190

4. Install the compression springs (for the valves).
5. Install the valve spring retainers.
6. Installation of valve spring retainer locks
Insert the valve rocker shaft into position. Install the valve spring retainer lock, using the following SST.
SST: 09201-87702-000

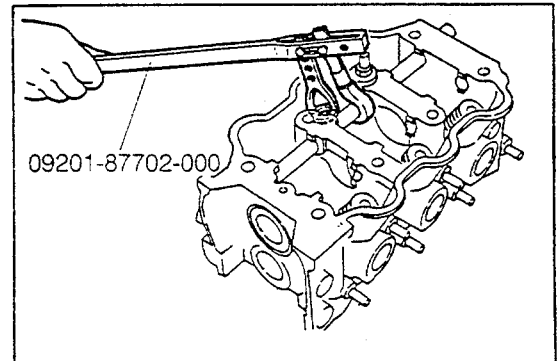

Fig. 5-166

WM-05191

After the valve spring retainer lock has been installed, lightly tap the valve retainer, using a plastic hammer. In this way, ensure that the valve spring retainer lock is installed securely.

NOTE:

During this check, care must be exercised to ensure that the valve spring retainer or lock retainer may not be jumped out.

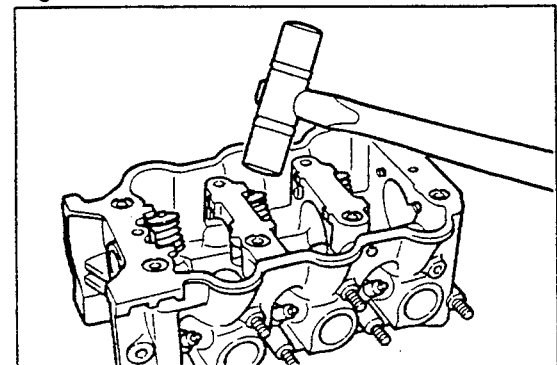

Fig. 5-167

WM-05192

7. Installation of oil seals
Install a new oil seal to the cylinder head, using the following SST.
SST: 09515-87202-000

After the oil seal has been installed, apply engine oil to the oil seal lip section.

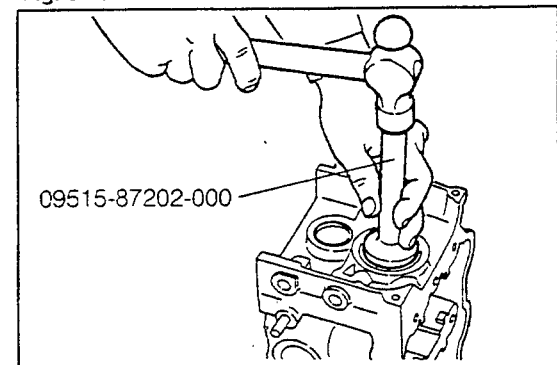

Fig. 5-168

WM-05193

ENGINE MECHANICALS

8. Installation of camshaft

- (1) Apply engine oil to the camshaft bearing bores of the cylinder head.
- (2) Apply engine oil to the camshaft journal sections.
- (3) Assemble the camshaft to the cylinder head, being very careful not to damage the camshaft bearing bores of the cylinder head.

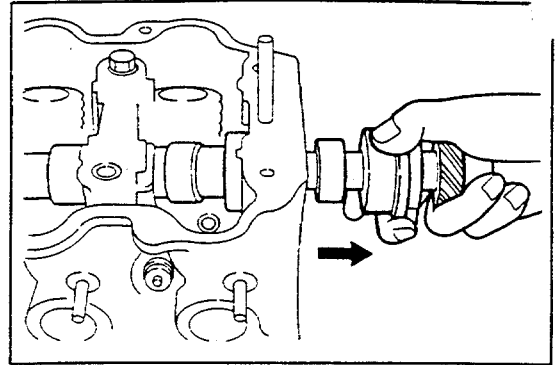

Fig. 5-169

WM-05194

9. Installation of valve rocker shafts, valve rocker arms and compression springs (for valve rocker shafts)

Apply oil to the valve rocker shafts, valve rocker arms, compression springs and valve rocker shaft attaching holes of the cylinder head. Then, install these parts.

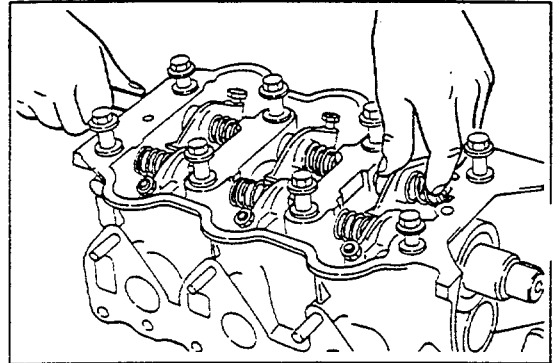

Fig. 5-170

WM-05195

NOTE:

The length of the valve rocker shaft differs between the exhaust side and the intake side.

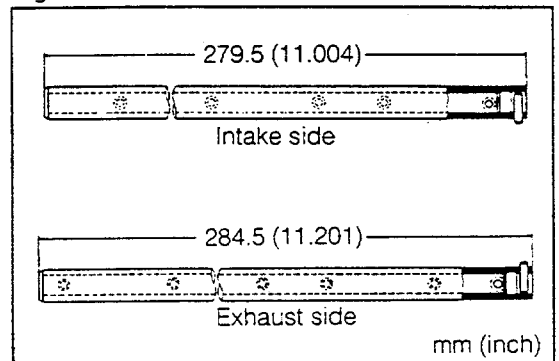

Fig. 5-171

WM-05196

10. Installation of wave washer

Apply engine oil to the wave washer. Assemble it to the cylinder head.

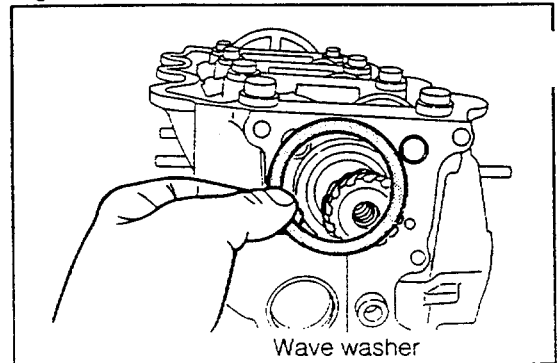

Fig. 5-172

WM-05197

11. Installation of distributor housing

Tighten the distributor housing to the specified torque.

Tightening Torque: 0.4 - 0.7 kg-m (2.9 - 5.1 ft-lb)

NOTE:

Be sure to use a new O-ring.

WM-05198

Adjustment of valve clearances

After the distributor housing has been installed, adjust the valve clearances.

Exhaust valve — 0.15 mm (0.006 inch)

Intake valve — 0.15 mm (0.006 inch)

- (1) Turn the camshaft, until the camshaft woodruff key comes at the exact top position. Then, adjust the clearances of the intake and exhaust valves of the cylinder No.1, the exhaust valve of the cylinder No.2 and the intake valve of the cylinder No.3.
- (2) Turn the camshaft, until the camshaft woodruff key comes at the exact bottom position. Then, adjust the clearances of the intake valve of the cylinder No.2 and the exhaust valve of the cylinder No.3.
- (3) After the valve clearances have been adjusted, turn the camshaft, until the camshaft woodruff key comes at the top position.

NOTE:

After the engine assembly has been mounted on the vehicle, warm up the engine fully. Readjust the valve clearances to the specifications for hot operation.

Reference

Camshaft position		No. of cylinder		
		1	2	3
Camshaft woodruff key position: exact top	Intake valve	○		○
	Exhaust valve	○	○	
Camshaft woodruff key position: exact bottom	Intake valve		○	
	Exhaust valve			○

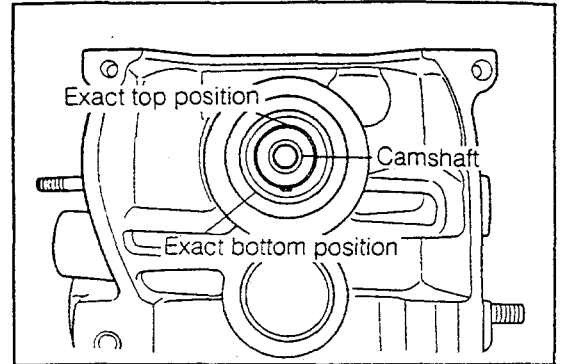

Fig. 5-173

WM-05199

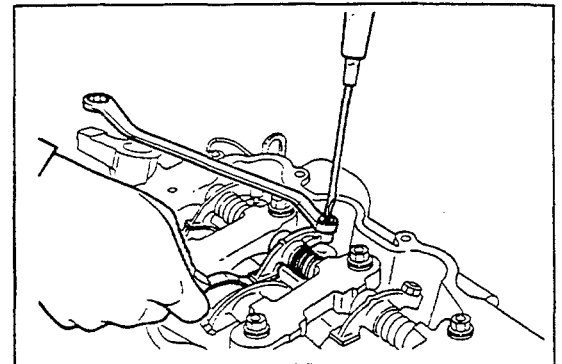

Fig. 5-174

WM-05200

13. Installation of cylinder head assembly

- (1) Remove the cylinder head from the SST.
- (2) Install a new cylinder head gasket on the cylinders.
- (3) Check to see if oil or water, etc. is present in the attaching holes of the cylinder head bolts at the cylinder block side. Remove any oil or water which is present by blowing compressed air.
- (4) Turn the camshaft key, until the camshaft woodruff key comes at the exact top position.

NOTE:

At this time, make sure that the crankshaft comes at the top dead center under the compression stroke of the cylinder No.1.

- (5) Install the cylinder head onto the cylinder head gasket surface, being very careful not to scratch the gasket.

WM-05201

ENGINE MECHANICALS

- (6) Insert the cylinder head bolts into position. Tighten the bolts to the specified torque in the sequence indicated in the right figure.

Tightening Torque: 5.5 - 6.5 kg-m (40 - 47 ft-lb)

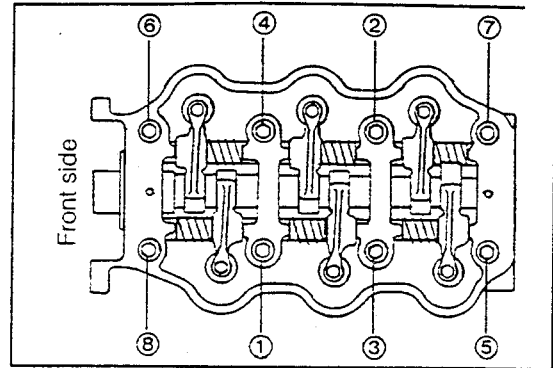

Fig. 5-175

WM-05202

14. Installation of distributor

- (1) Ensure that the cylinder No.1 is at the top dead center under the compression stroke or that the camshaft woodruff key comes at the exact top position.

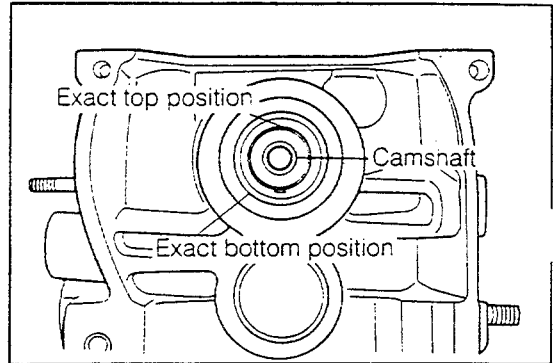

Fig. 5-176

WM-05204

- (2) Determine the position of the distributor shaft by aligning the punch mark at the end of the distributor with the recessed mark, as shown in the right figure.

NOTE:

Fill about 30 cc of engine oil in the distributor housing.

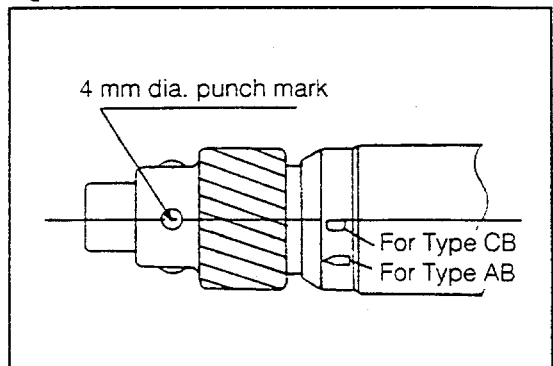

Fig. 5-177

WM-05205

- (3) Insert the distributor proper into the distributor housing in such a way that the split line of the distributor proper may be aligned with the embossed line of the distributor housing.

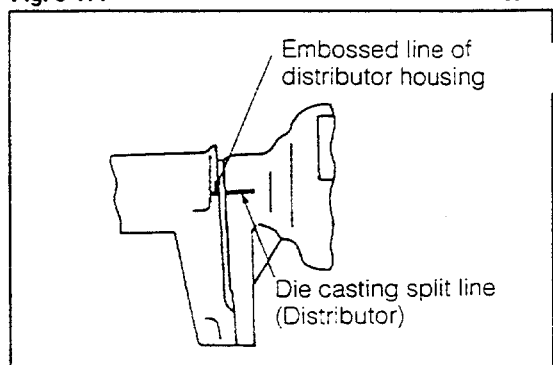

Fig. 5-178

WM-05206

- (4) Tighten the attaching bolts of the distributor temporarily.

NOTE:

Tighten the attaching bolts securely after the engine assembly has been mounted on the vehicle and the engine tune-up has been performed.

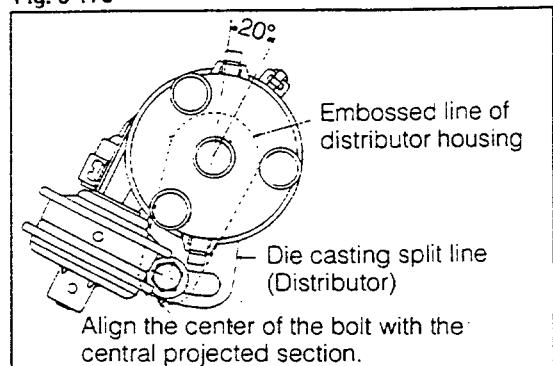
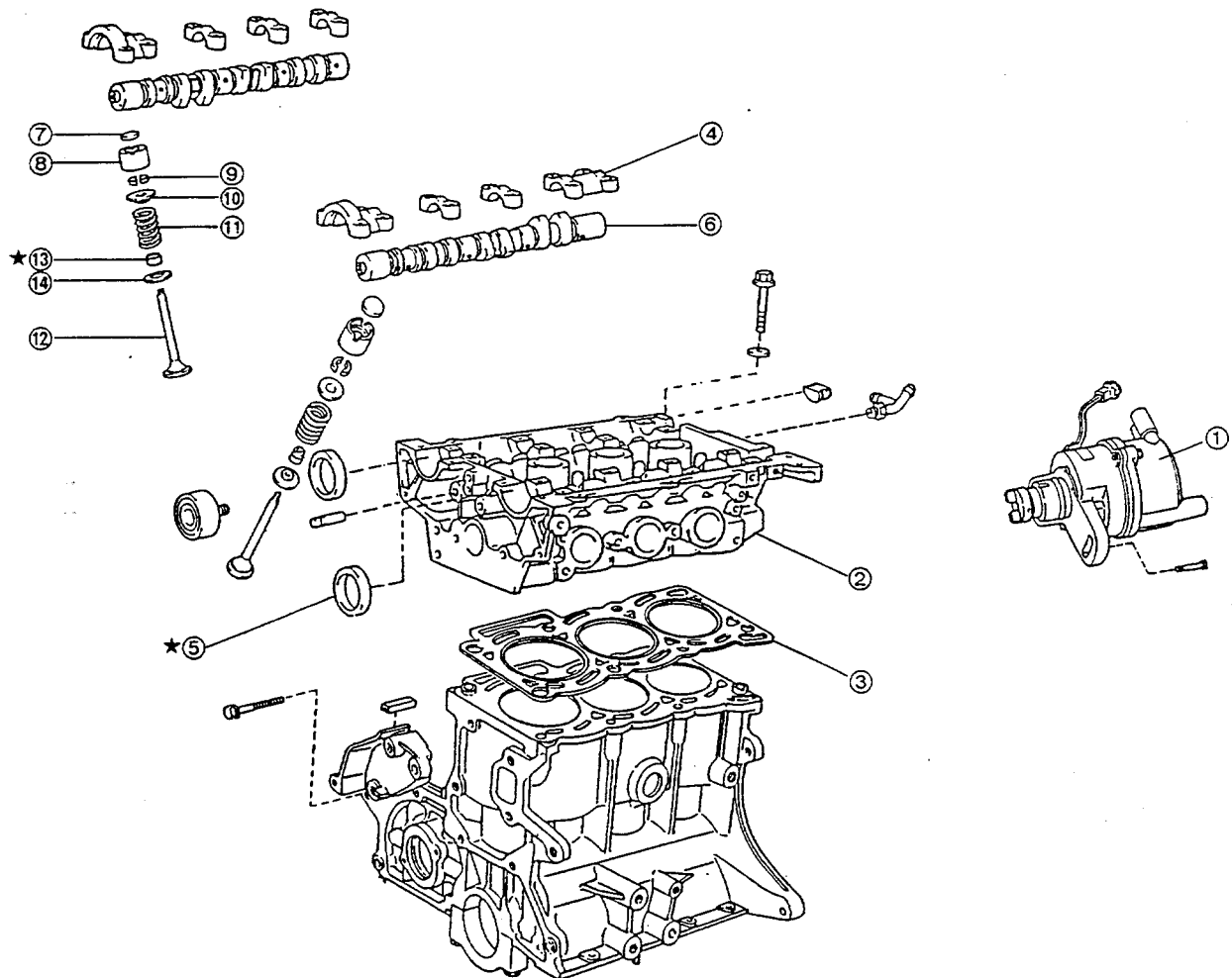

Fig. 5-179

WM-05207

**B-80 ENGINE
COMPONENTS OF CYLINDER HEAD**



★ : Non-reusable parts

- | | |
|------------------------|------------------------------|
| ① Distributor Ay | ⑧ Valve lifter |
| ② Cylinder head Ay | ⑨ Valve spring retainer lock |
| ③ Cylinder head gasket | ⑩ Valve spring retainer |
| ④ Camshaft bearing cap | ⑪ Compression spring |
| ⑤ Oil seal | ⑫ Valve |
| ⑥ Camshaft | ⑬ Valve stem oil seal |
| ⑦ Shim | ⑭ Valve spring seat |

Fig. 5-180

WM-05208

ENGINE MECHANICALS

REMOVAL

1. Remove the distributor assembly.
2. Remove the cylinder head assembly.
 - (1) Loosen the cylinder head bolts gradually over two or three stages, following the sequence indicated in the right figure. Then, pull out the cylinder head bolts.

- (2) Remove the cylinder head. Attach the cylinder head to the SST. Fit the SST in a vise securely.

SST: 09219-87703-000

NOTE:

Be very careful not to scratch the gasket surface of the cylinder head.

3. Remove the cylinder head gasket.
4. Remove the camshaft bearing caps.
 - (1) Turn the camshaft about 30 degrees counterclockwise so that the tappet may be brought under a non-compressed state.
 - (2) Pull out the camshaft bearing cap bolts.

NOTE:

Be sure to alternately slacken the camshaft bearing cap bolts over two or three stages.

5. Remove the oil seal.
6. Remove the camshaft.
7. Remove the shims.

NOTE:

Arrange the removed shims in order so that their installation positions may be known readily.

8. Remove the valve lifters.

NOTE:

Arrange the removed valve lifters in order so that their installation positions may be known readily.

9. Removal of valve spring retainer locks
Remove the valve spring retainer lock, using the following SSTs.

SST: 09202-87002-0A0
09202-87002-000

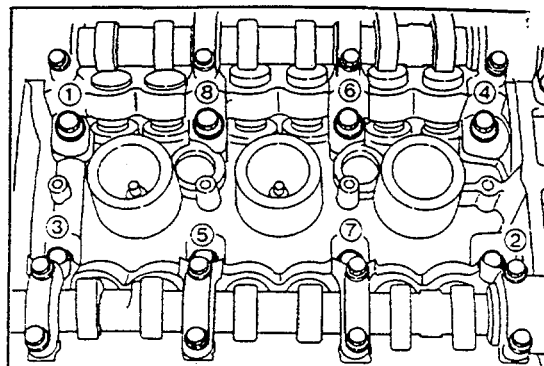

Fig. 5-181

WM-05209

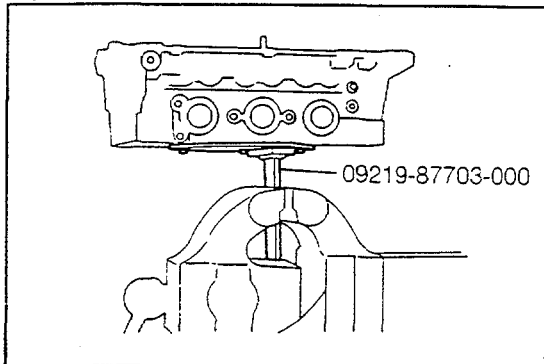

Fig. 5-182

WM-05210

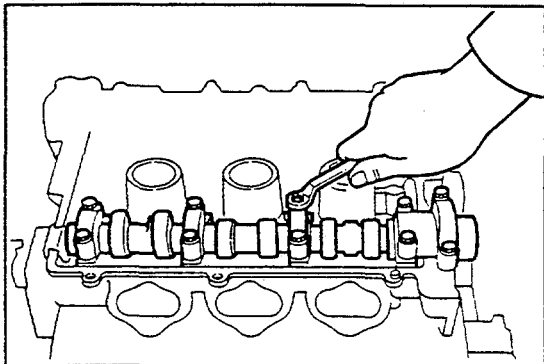

Fig. 5-183

WM-05211

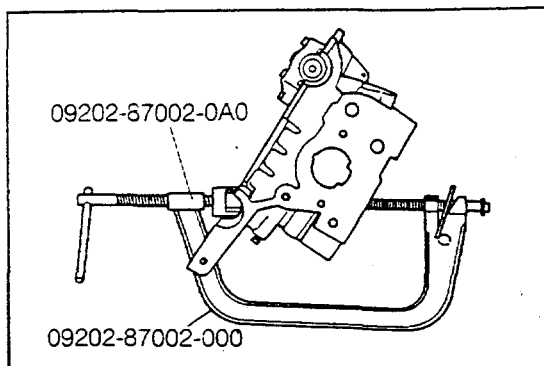

Fig. 5-184

WM-05213

- . Remove the valve spring retainers.
- 11. Remove the compression springs.
- 12. Remove the valves.
- 13. Remove the valve stem oil seals.
- 14. Remove the valve spring seats.
- 15. Remove the cylinder head from the SST.

NOTE:

Wash the removed parts with a cleaning solvent and blow them by compressed air.
(Do not use a cloth or the like to wipe the parts.)

WM-05214

INSPECTION

1. Checking of cylinder head
 - (1) Check the cylinder head for cracks, damage and distortion.
If the cylinder head exhibits cracks or damage, replace it, as required.
Check the cylinder head for distortion on the following three surfaces.
 - ① Distortion of cylinder block gasket surface
Maximum Limit: 0.10 mm (0.039 inch)
 - ② Distortion of intake manifold attaching surface
Maximum Limit: 0.10 mm (0.039 inch)
 - ③ Distortion of exhaust manifold attaching surface
Maximum Limit: 0.10 mm (0.039 inch)

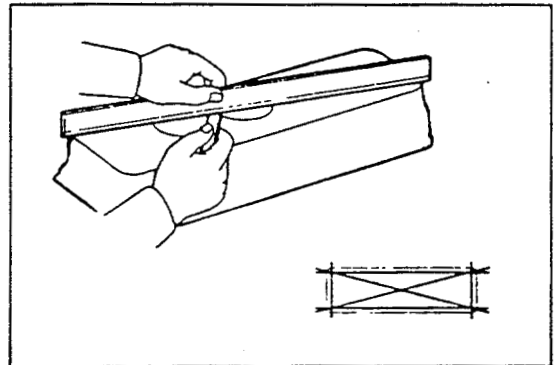

Fig. 5-185

WM-05215

NOTE:

If the distortion exceeds the maximum limit, replace the cylinder head.

- (2) Checking valve seats

Apply a thin film of red lead to the valve seat. Let the valve drop by its own weight onto the valve seat two or three times. Take out the valve. Measure the width of the contact surface of the valve seat.

Specified Value: 1.2 - 1.6 mm (0.047 - 0.063 inch)

NOTE:

If the valve-to-valve seat contact surface does not conform to the specifications or the contact surface exhibits roughness, correct the cylinder head or replace it, as required.

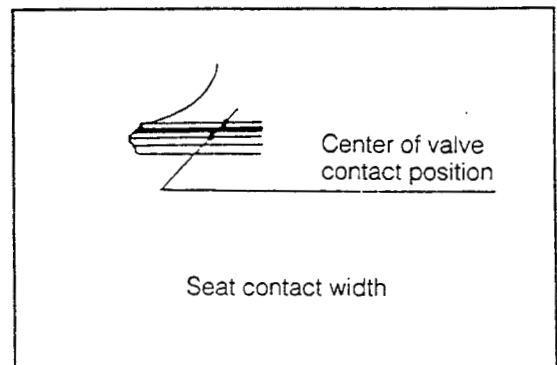

Fig. 5-186

WM-05216

(3) Refacing valve seats

Reface the valves, using a valve seat cutter.

NOTE:

If the valve guide bush is worn, first replace it. Then, proceed to the valve seat refacing.

WM-05217

• Refacing procedure for intake valve seats

- ① Recondition the roughness on the valve-to-valve seat contact surface, using a 45-degree cutter.

- ② Using a 30-degree cutter, cut the valve seat in such a way that the circumference of the surface refaced by the 45-degree cutter may become 29 ± 0.1 mm (1.14 ± 0.004 inches).

- ③ Using a 70-degree cutter, cut the valve seat in such a way that the width of the surface refaced by the 45-degree cutter may become 1.4 ± 0.2 mm (0.055 ± 0.008 inches).

- ④ Using the 45-degree cutter, remove burrs produced during the refacing by the 30-degree and 70-degree cutters.

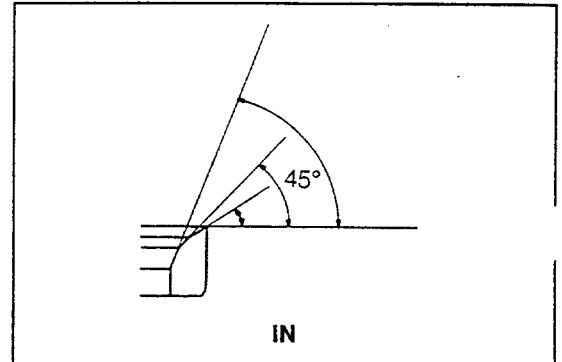

Fig. 5-187

WM-05218

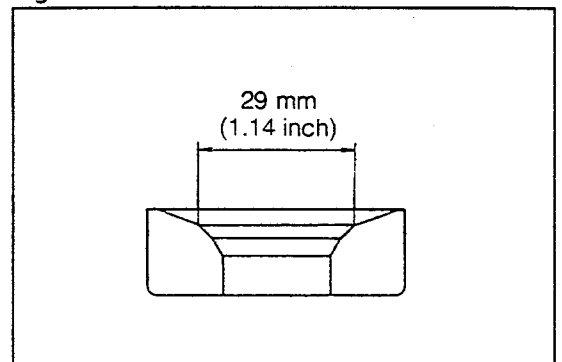

Fig. 5-188

WM-05219

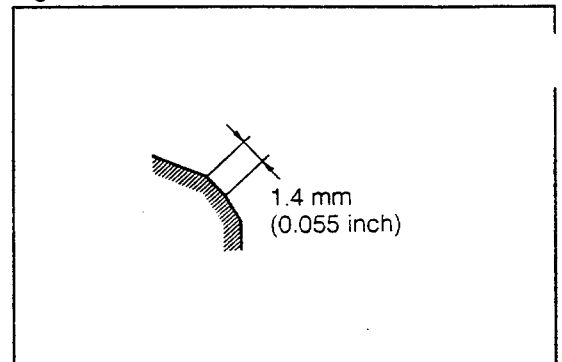

Fig. 5-189

WM-05220

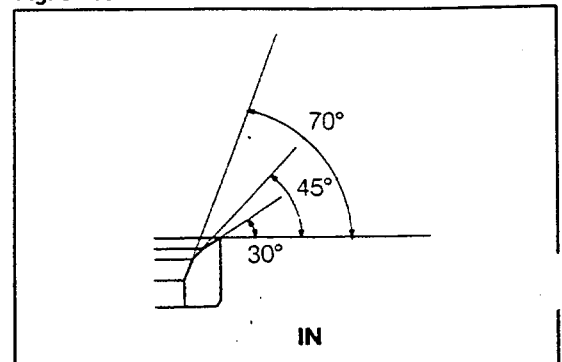

Fig. 5-190

WM-05221

● Refacing procedure for exhaust valve seats

① Recondition the roughness on the valve-to-valve seat contact surface, using a 45-degree cutter.

② Using a 20-degree cutter, cut the valve seat in such a way that the circumference of the surface refaced by the 45-degree cutter may become 25.0 ± 0.1 mm (0.98 ± 0.004 inches).

③ Using a 70-degree cutter, cut the valve seat in such a way that the width of the surface refaced by the 45-degree cutter may become 1.4 ± 0.2 mm (0.055 ± 0.008 inches).

④ Using the 45-degree cutter, remove burrs produced during the refacing by the 20-degree and 70-degree cutters.

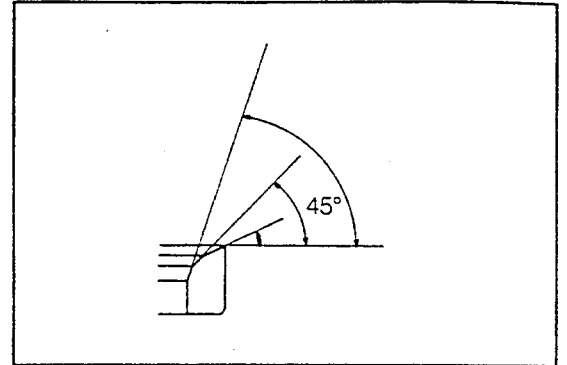

Fig. 5-191

WM-05222

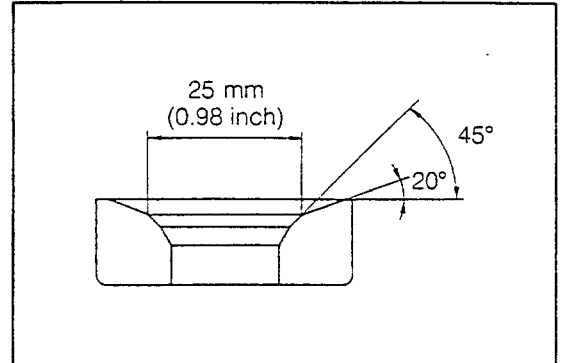

Fig. 5-192

WM-05223

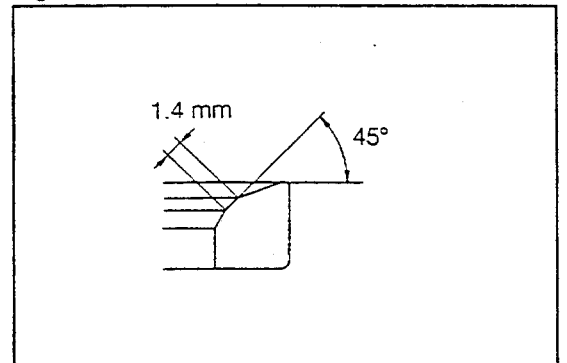

Fig. 5-193

WM-05224

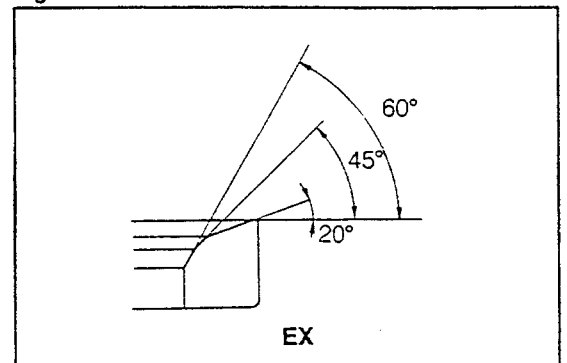

Fig. 5-194

WM-05225

ENGINE MECHANICALS

(4) Checking of valve seat recession

After completion of the valve seat refacing, using a micrometer, measure the clearance between the upper end of the valve seat surface refaced by the 45-degree cutter and the cylinder head gasket surface.

Maximum Limit

Intake valve: 4.23 mm (0.1665 inch)

Exhaust valve: 5.30 mm (0.2087 inch)

NOTE:

If the recession exceeds the maximum limit, replace the cylinder head.

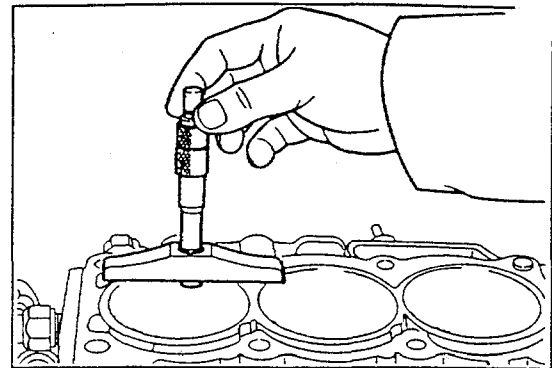

Fig. 5-195

WM-05226

2. Checking of valves

(1) Checking valve stems

Visually inspect the valve stem for seizure or damage. If the valve exhibits damage, replace it together with the valve guide bush as a set.

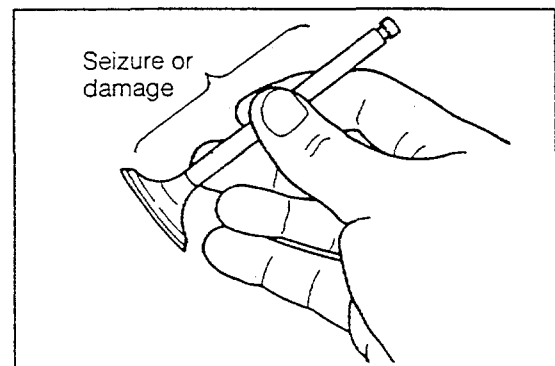

Fig. 5-196

WM-05227

(2) Checking valve stem end

① Check the valve stem end for abnormal wear or damage.

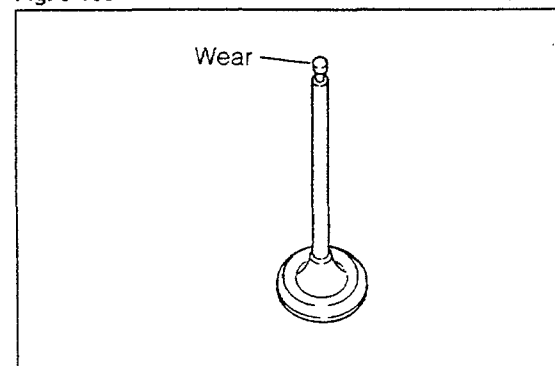

Fig. 5-197

WM-05228

② If the valve stem exhibits abnormal wear, correct the stem end with a valve refacer. However, make sure that the valve has the following minimum valve overall length given below.

Minimum Valve Overall Length:

Intake valve: 106.4 mm (4.189 inches)

Exhaust valve: 106.6 mm (4.197 inches)

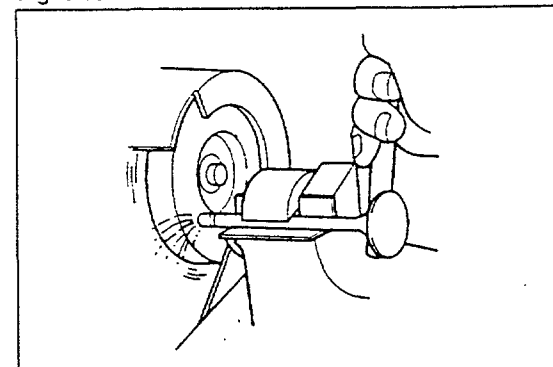

Fig. 5-198

WM-05229

- (3) Checking of valve heads
- ① Check the valve-to-valve seat contact surface for roughness or damage.

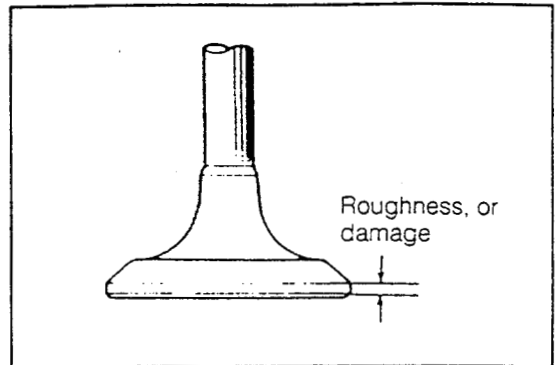

Fig. 5-199

WM-05230

- ② If the valve-to-valve seat contact surface exhibits any damage, grind the surface with a valve refacer.
Valve Face Angle: 45.5

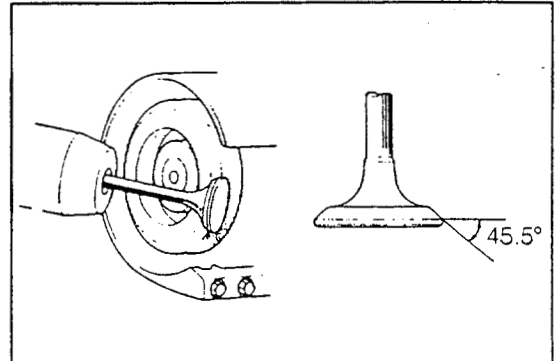

Fig. 5-200

WM-05231

- ③ After the valve head has been ground, measure the stock thickness of the valve head.
Minimum Limit Intake valve 0.7 mm (0.028 inch)
Exhaust valve 0.8 mm (0.031 inch)

NOTE:

If the stock thickness of the valve head is less than the limit, replace it with a new one.
When replacing the valve head, be sure to check the oil clearance with the valve guide bush.

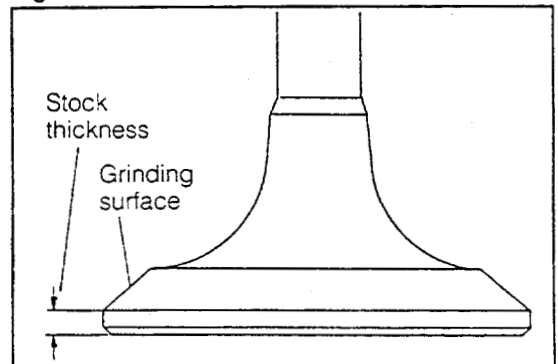

Fig. 5-201

WM-05232

3. Checking of valve guide bush-to-valve stem oil clearance
- (1) Measuring oil clearance

Measure the valve guide bush-to-valve stem oil clearance.
Oil clearance = Inner diameter of valve guide bush – Outer diameter of valve stem
Specified Value: Intake valve: 0.025 - 0.08 mm (0.0009 - 0.0031 inch)
Exhaust valve: 0.030 - 0.09 mm (0.0012 - 0.0035 inch)

WM-05233

- ① Measurement of inner diameter of valve guide bush
Perform the measurement at six points.

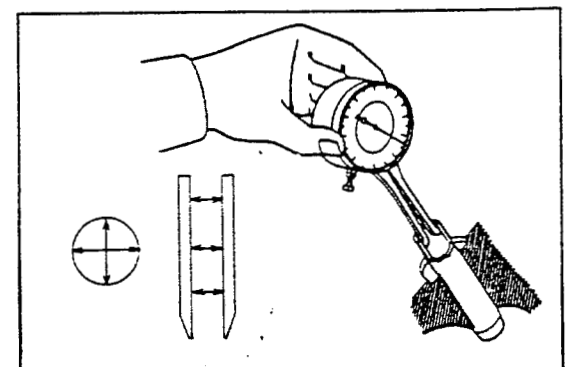

Fig. 5-202

WM-05234

ENGINE MECHANICALS

- ② Measurement of outer diameter of valve stem
Perform the measurement at six points.

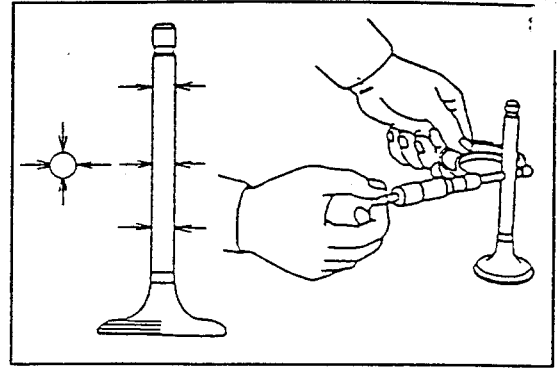

Fig. 5-203

WM-05235

- (2) Replacing valve guide bush if necessary

NOTE:

When replacing the valve guide bush, replace also the valve as a set. However, if the intake valve guide bushes with rings (replacement part) have been already installed as valve guide bushes, replace the cylinder head.

WM-05236

• Exhaust side

- ① Drive out valve guide bush from the combustion chamber side, using the SST.

SST: 09201-87201-000

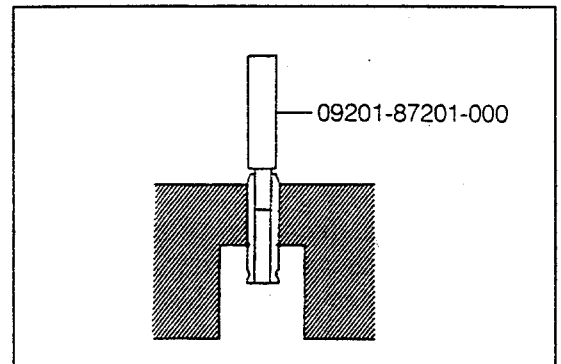

Fig. 5-204

WM-05237

- ② Measure the inner diameter of the installation hole of the valve guide bush of the cylinder head.

Specified Inner Diameter:

11.05 mm dia. (0.45 inch dia.)

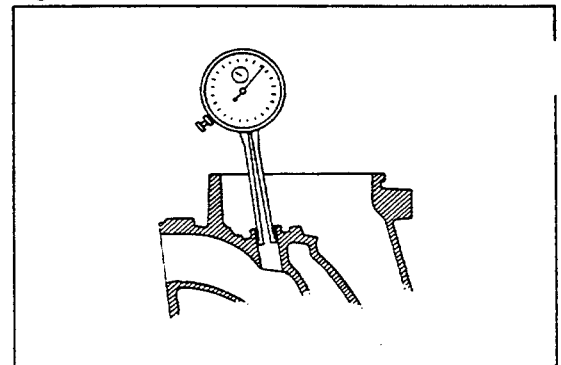

Fig. 5-205

WM-05239

NOTE:

If the measured value exceeds the specified value, replace the cylinder head.

- ⑤ Drive a new valve guide bush into position, until the snap ring contacts the cylinder head, using the following SST.

SST: 09201-87201-000

NOTE:

After the valve guide bush has been driven into position, remove any burr or the like, using an adjustable reamer. At this time, make sure that the specified oil clearance is assured between the valve guide bush and the valve stem.

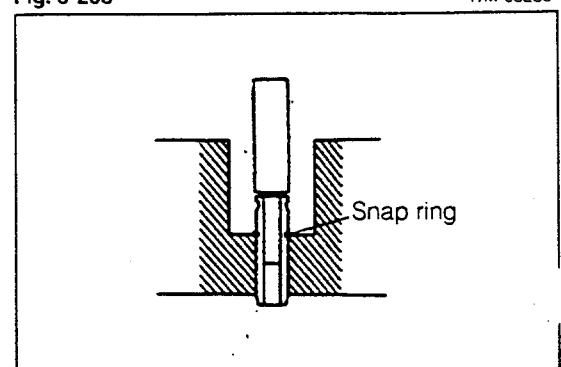

Fig. 5-206

WM-05240

• Intake side

- ① Drive out the valve guide bush from the combustion chamber side, using the following SST.

SST: 09201-87201-000

- ② Drive a new valve guide bush into position, until the snap ring contacts the cylinder head, using the following SST.

SST: 09201-87201-000

NOTE:

After the valve guide bush has been driven into position, remove any burr or the like, using an adjustable reamer. At this time, make sure that the specified oil clearance is assured between the valve guide bush and the valve stem.

4. Checking of valve springs

- (1) Check the valve spring for squareness, using a square.

Maximum limit: 1.6 mm (0.063 inch)

- (2) Using a spring tester, measure the free length. Also, measure the spring tension with the spring compressed to the specified installed length.

Minimum free length: 44.5 mm (1.75 inches)

Spring tension:

Minimum limit/installation height

34.4 kg/27.67 mm (75.9 lb/1.09 inches)

5. Checking of valve lifters and shims

- (1) Check the valve lifter shim surfaces for wear or damage.

NOTE:

If the valve lifter exhibits wear or damage, replace it with a shim of the same size as the original valve lifter shim. (The shim size is stamped on the valve lifter shim.)

- (2) Checking valve lifters

Check the valve lifters for seizure or damage.

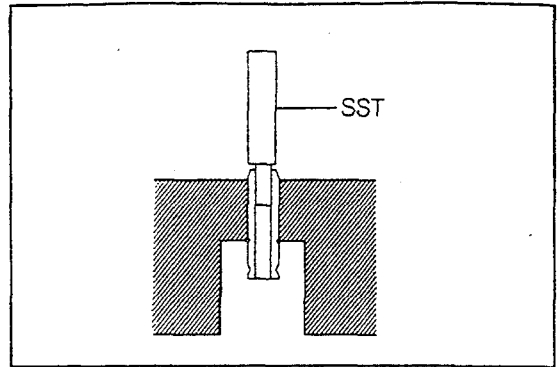

Fig. 5-207

WM-05241

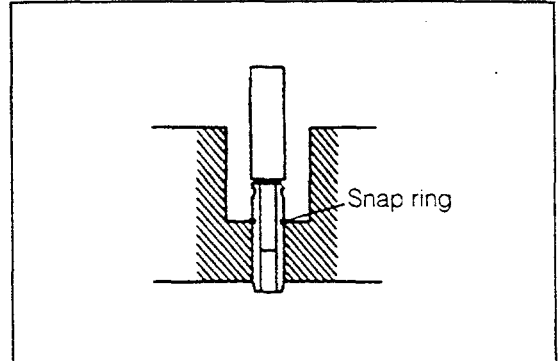

Fig. 5-208

WM-05242

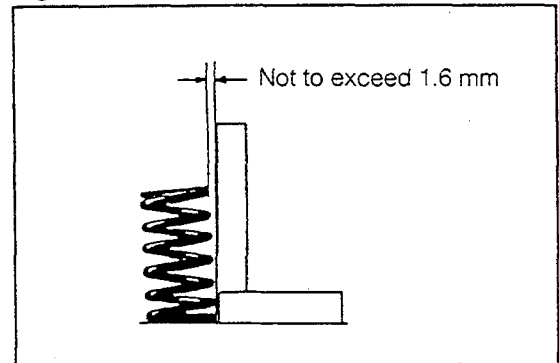

Fig. 5-209

WM-05243

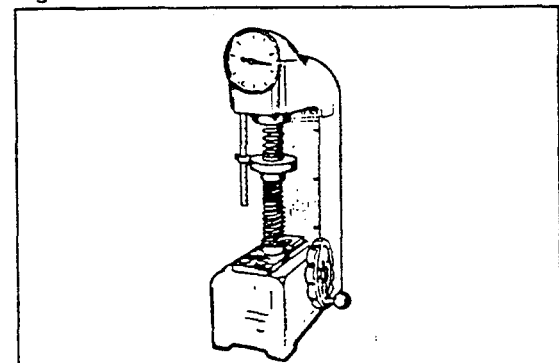

Fig. 5-210

WM-05244

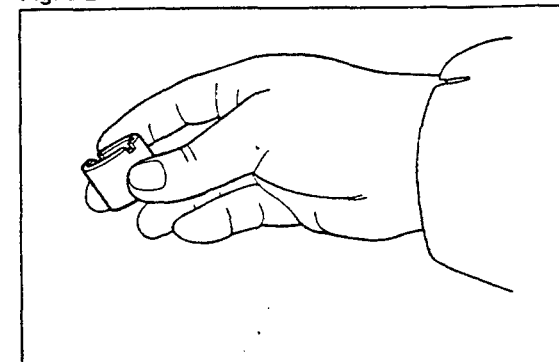

Fig. 5-211

WM-05245

ENGINE MECHANICALS

6. Checking of valve lifter-to-cylinder head oil clearance

WM-05246

- (1) Measure the inner diameter of the valve lifter hole of the cylinder head.

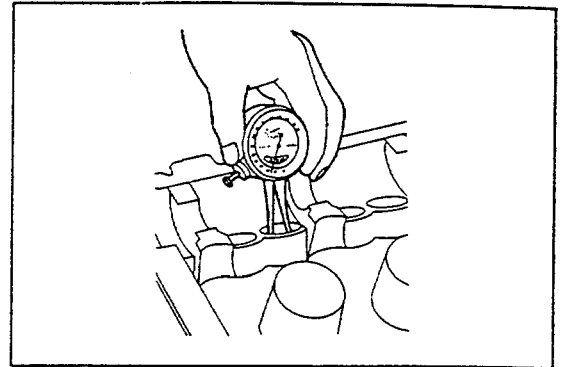

Fig. 5-212

WM-05247

- (2) Measure the outer diameter of the valve lifter.
This measurement should be conducted in two directions, 90 degrees apart from each other.

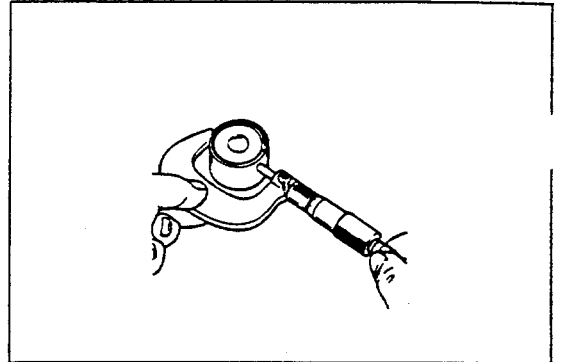

Fig. 5-213

WM-05248

Oil clearance 0.015 - 0.07 mm (0.0006 - 0.0028 inch)

If the oil clearance exceeds the specified value, replace the valve lifter with a new one and/or cylinder head, as required, referring to the following specified dimensions of new valve lifters.

Outer diameter of valve lifter (New part)

29.975 - 29.985 mm (1.1801 - 1.1805 inches)

WM-05249

7. Checking of camshaft

- (1) Checking camshaft for runout

Support the camshaft at its both ends with V-shaped blocks. Set a dial gauge to each of the camshaft journal sections No.2, No.3, No.6 and No.7. Turn the camshaft one turn, making sure that the camshaft will not move in the axial direction. Take a reading on the dial gauge during the turning. Calculate the maximum runout, i.e. the difference between the maximum and minimum readings.

Maximum runout: 0.03 mm (0.0012 inch)

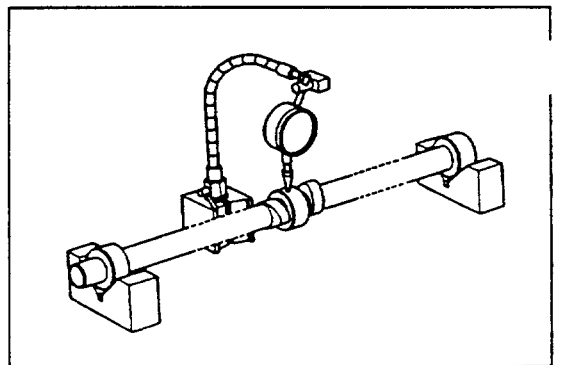

Fig. 5-214

WM-05250

- (2) Checking cam lobe height

Measure the cam lobe height.

Minimum limit Intake valve 39.4 mm (1.55 inches)

Exhaust valve 39.0 mm (1.53 inches)

If the measured height is less than the minimum limit, replace the camshaft.

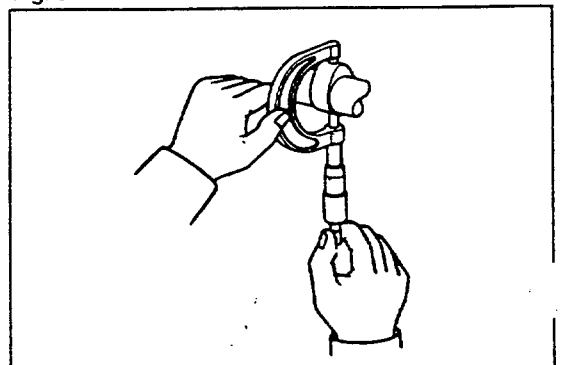

Fig. 5-215

WM-05251

- (3) Checking oil clearance
 With the bearing cap tightened to the specified torque, measure the oil clearance, using the plastigage.
Tightening Torque: 1.3 ± 0.15 kg-m (9.4 ± 1.1 ft-lb)
Oil Clearance:
 0.025 - 0.16 mm (0.0010 - 0.0063 inch)

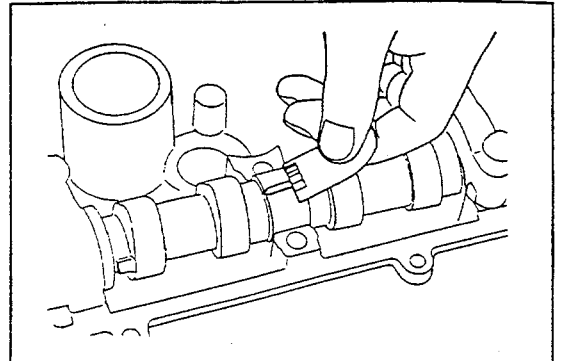

Fig. 5-216

WM-05252

- (4) Checking thrust clearance
 After the bearing caps have been tightened to the specified torque, check the thrust clearance.
Maximum limit: 0.20 mm (0.0078 inch)

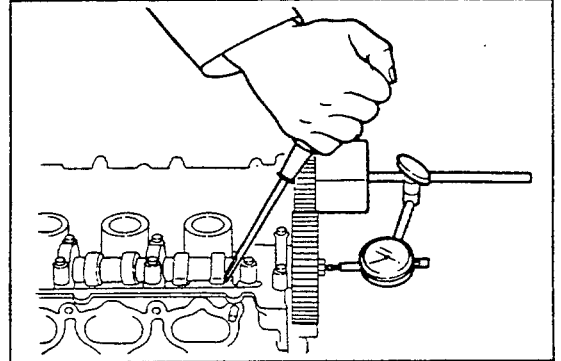

Fig. 5-217

WM-05253

8. Hand lapping of valves
 After all checks have been completed, carry out hand lapping of the valves before assembling them.
 Apply a thin film of abrasive compound to the valve and valve seat. Perform the lapping with a valve lapper.
 After completion of the lapping, wash the valves and cylinder head, using a cleaning solvent. Blow them with compressed air.

WM-05254

INSTALLATION

- Install the cylinder head to the SST (09219-87703-000).
 Install the valve spring seats.
 -- Installation of valve stem oil seals
 Apply engine oil to a new valve stem oil seal. Then, insert it into the valve guide bush by your hands.

3. Installation of valves
 Apply engine oil to the valve stem. Insert it into the valve guide bush from the combustion chamber side, being very careful not to damage the valve stem oil seal.

NOTE:

- (1) Be sure to install the valves, valve springs and valve retainers into the original position to which they were installed before the disassembly. (This does not apply to the replaced parts.)
- (2) Once the valve has been inserted, never pull it out from position. If the valve should be pulled out, replace the valve stem oil seal with a new one.

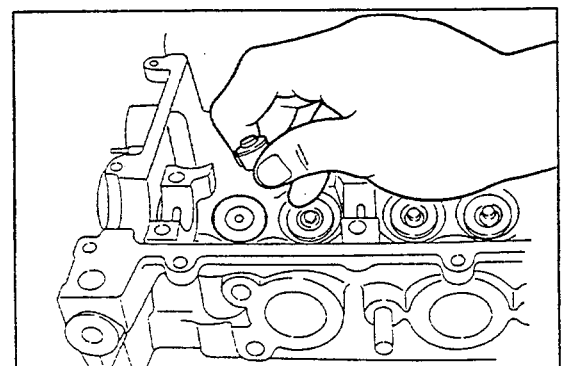

Fig. 5-218

WM-05255

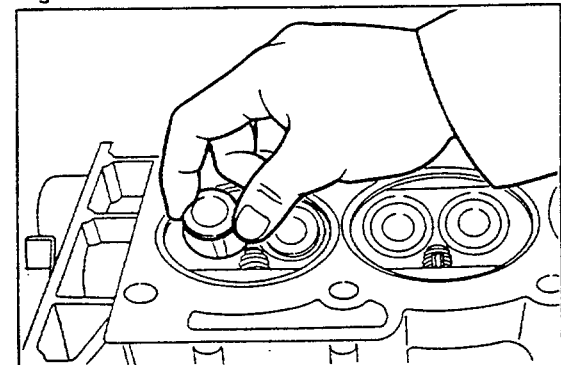

Fig. 5-219

WM-05256

ENGINE MECHANICALS

4. Installation of compression springs
Assemble the compression spring with the white-painted side facing the cylinder head.

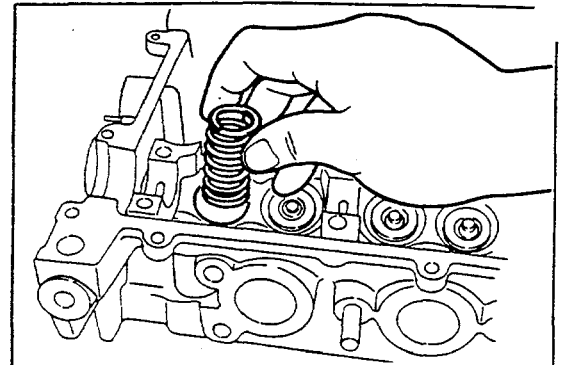

Fig. 5-220

WM-05257

5. Install the valve spring retainers.
6. Installation of valve spring retainer locks
Install the valve spring retainer lock, using the following SSTs.

SST: 09202-87002-0A0
09202-87002-000

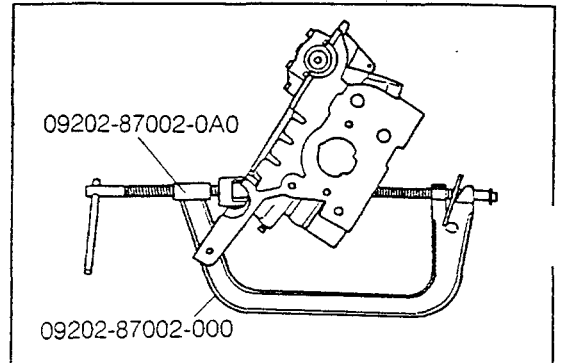

Fig. 5-221

WM-05258

After the valve spring retainer lock has been installed, lightly tap the valve retainer, using a plastic hammer. In this way, ensure that the valve spring retainer lock is installed securely.

NOTE:

During this check, care must be exercised to ensure that the valve spring retainer or lock retainer may not be jumped out.

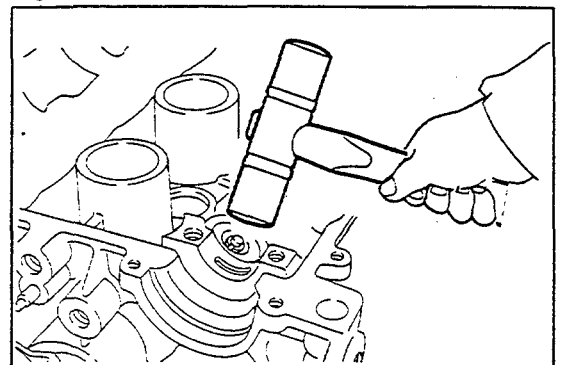

Fig. 5-222

WM-05259

7. Installation of valve lifters
Apply engine oil to the cylinder head valve lifter hole and valve lifter. Then, insert the valve lifter into position.

NOTE:

Make sure that the valve lifter can be rotated lightly.

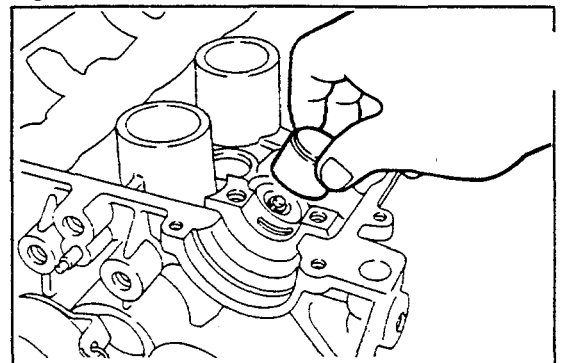

Fig. 5-223

WM-05260

8. Installation of shims
Install the shims in the same number as installed before the disassembly. The shim should be installed with the size-indicated side facing toward the lifter.

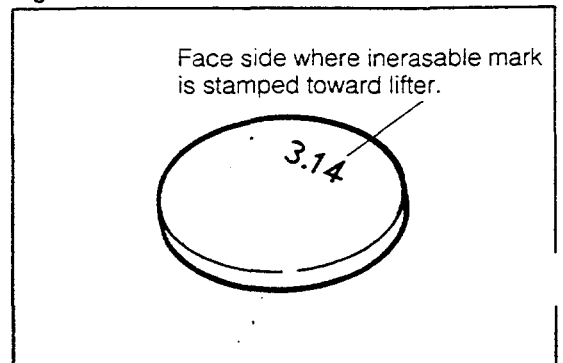

Fig. 5-224

WM-05261

Installation of camshafts

- (1) Apply engine oil to the camshaft bearing bores of the cylinder head.
- (2) Apply engine oil to the camshaft journal sections where the oil seals have been assembled. Then, install the camshaft to the cylinder head.
- (3) For identification purpose, the camshaft for exhaust valve use has a groove for driving the distributor, as indicated in the right figure.

NOTE:

Set each camshaft to the initial position. Namely, set each of the camshafts to a state where the camshaft pushes no valve lifter.

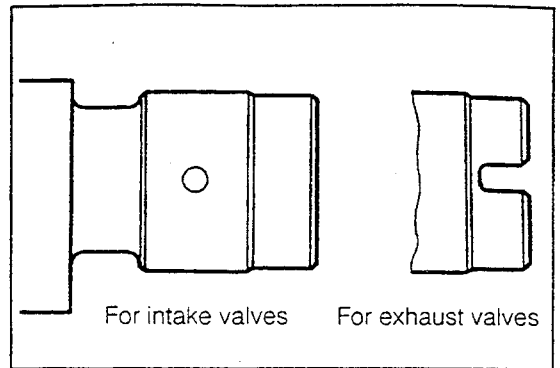

Fig. 5-225

WM-05263

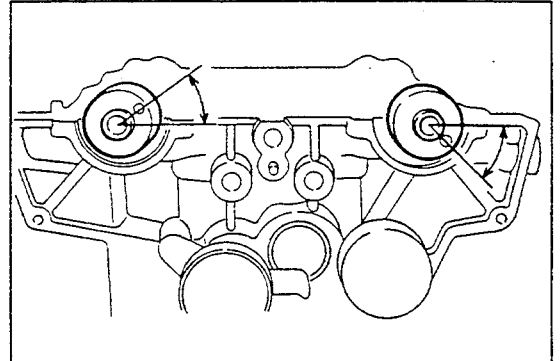

Fig. 5-226

WM-05264

10. Installation of camshaft bearing caps

Apply engine oil to the inside of each camshaft bearing cap. Then, evenly tighten the camshaft bearing caps to the specified torque.

Tightening Torque: 1.15 - 1.45 kg-m (8.3 - 10.5 ft-lb)

NOTE:

- ① Make sure that the oil seal may not tilt during the bearing cap installation.
- ② Be sure to install each camshaft bearing cap correctly, according to the embossed number and arrow at the back side of the cap.

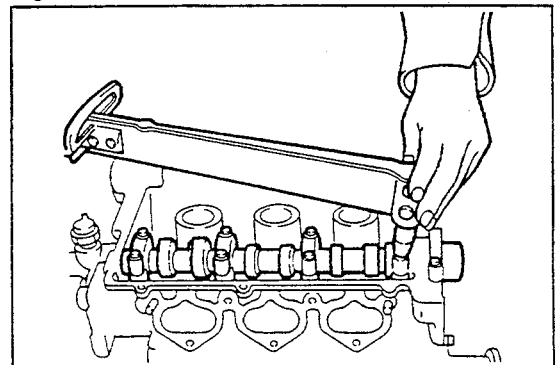

Fig. 5-227

WM-05265

Installation of oil seals

Apply engine oil to each new oil seal. Then, press it into position, using the following SST.

SST: 09618-87301-000

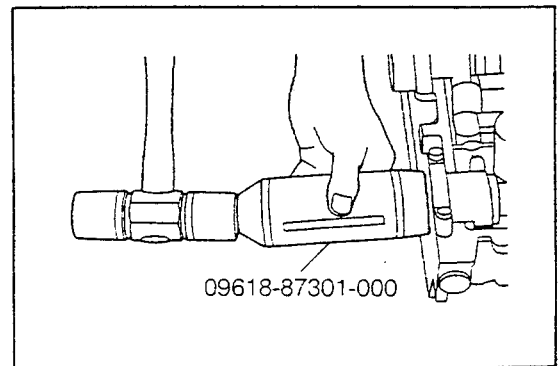

Fig. 5-228

WM-05262

12. Installation of cylinder head gasket

Install a new cylinder head gasket.

WM-05266

ENGINE MECHANICALS

13. Installation of cylinder head assembly

Tighten the bolts over two stages, following the sequence indicated in the right figure.

Tightening Torque:

First tightening 4.0 - 4.5 kg-m (29 - 33 ft-lb)

Second tightening 6.0 - 7.0 kg-m (43 - 51 ft-lb)

NOTE:

- ① Be very careful not to scratch the cylinder head and gasket during the installation.
- ② Make sure that no water or oil remains in the attaching holes of the cylinder head bolts.

14. Installation of distributor assembly

- (1) Remove the distributor cap. Tilt the rotor, as indicated in the right figure.
- (2) While turning the rotor, push and install the distributor assembly into the groove for driving the distributor.

NOTE:

Apply about 40 cc of engine oil between the camshaft journal sections. Also, apply about 10 cc of engine oil to the distributor dog chamber (at the rear end of the camshaft for exhaust valves).

15. Remove the cylinder head from the SST.

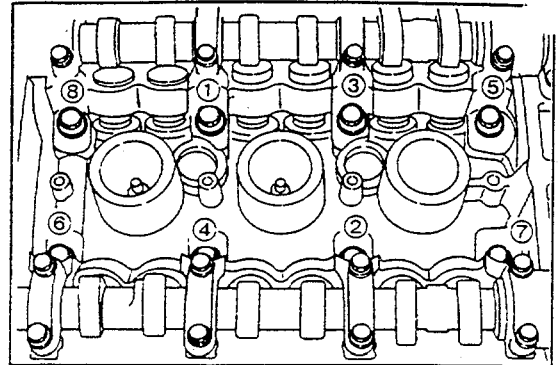

Fig. 5-229

WM-05267

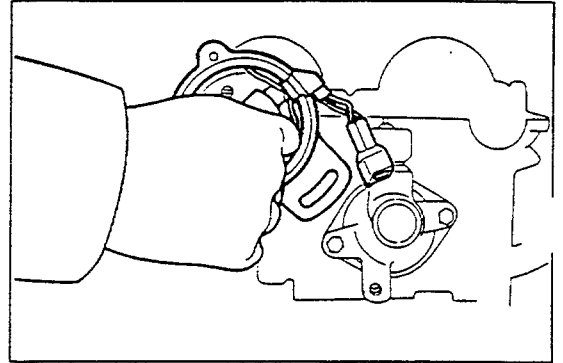

Fig. 5-230

WM-05268

WM-05269

1/ CYLINDER BLOCK

**(CB-23, CB-61 & CB-80 ENGINES)
COMPONENTS OF CYLINDER BLOCK**

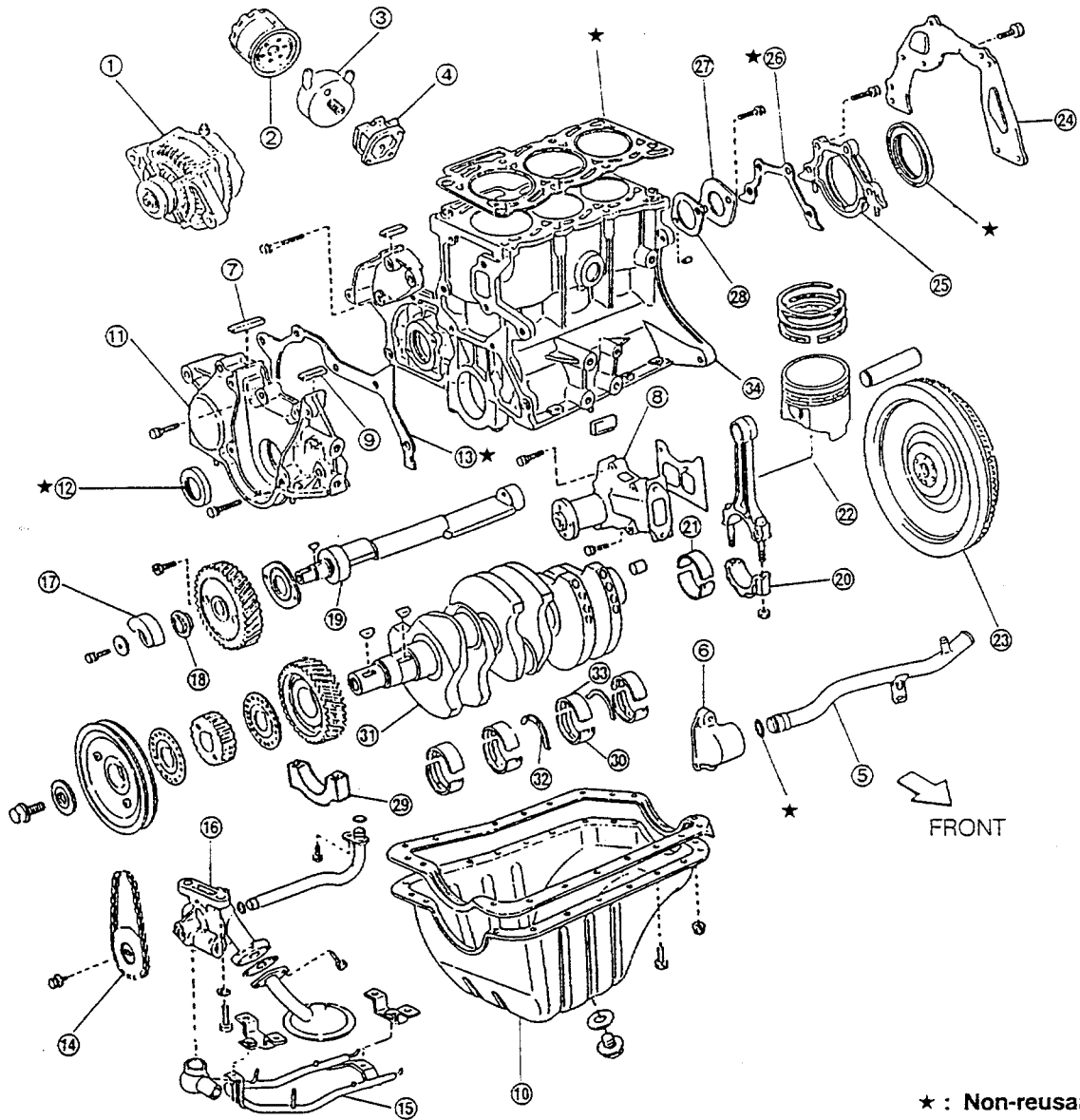

★ : Non-reusable parts

- | | |
|--|---|
| <ul style="list-style-type: none"> ① Alternator Ay ② Oil cleaner element ③ Oil cooler Ay (CB-61 & CB-80 engines only) ④ Oil filter bracket ⑤ Water inlet pipe ⑥ Water inlet ⑦ Dust seal ⑧ Water pump Ay ⑨ Dust seal ⑩ Oil pan ⑪ Balance shaft gear cover ⑫ Oil seal ⑬ Gasket ⑭ Oil pump drive sprocket & drive chain ⑮ Oil nozzle (CB-80 engine only) ⑯ Oil pump outlet pipe with oil pump ⌋ Balance weight | <ul style="list-style-type: none"> ⑰ Oil pump sprocket ⑱ Balance shaft ⑲ Connecting rod cap ⑳ Connecting rod bearing ㉑ Connecting rod with piston ㉒ Flywheel ㉓ Rear end plate ㉔ Oil seal retainer with oil seal ㉕ Gasket ㉖ Balance shaft rear cover ㉗ Balance shaft rear cover gasket ㉘ Crankshaft bearing cap ㉙ Crankshaft bearing (lower) ㉚ Crankshaft ㉛ Thrust washer ㉜ Crankshaft bearing (upper) ㉝ Cylinder block |
|--|---|

Fig. 5-231

ENGINE MECHANICALS

REMOVAL

1. Remove the alternator assembly.
2. Remove the oil cleaner element.
3. Remove the oil cooler assembly. (CB-61 & CB-80 engines only)
4. Remove the oil filter bracket.
5. Remove the water inlet pipe.
6. Remove the dust seal.
7. Remove the water pump assembly.
8. Remove the dust seal.
9. Remove the oil pan and oil pan gasket.
10. Remove the balance shaft gear cover.
11. Remove the crankshaft oil seal.
12. Remove the gasket.
13. Remove the balance weight.
14. Remove the oil pump drive sprocket and drive chain.
15. Remove the oil nozzle. (CB-80 engine only)
16. Remove the oil pump and oil pump outlet pipe.
17. Removal of balance shaft

WM-0521

- (1) Align the stamped mark on the crank shaft gear with the stamped mark on the balance shaft drive gear.

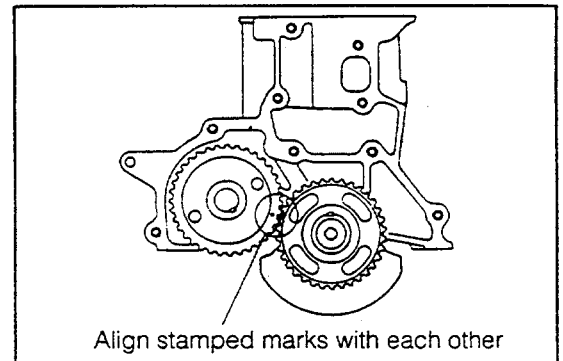

Fig. 5-232

WM-05272

- (2) Remove the hexagon socket head cap bolt, using a (5 mm) hexagon wrench key.
Pull out the balance shaft toward the front side of the cylinder block.

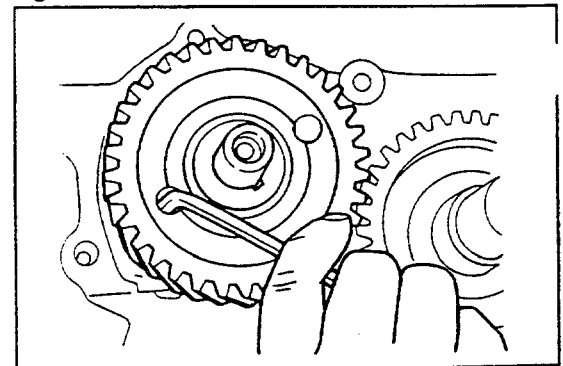

Fig. 5-233

WM-05273

18. Removal of connecting rod bearing cap

- (1) Turn the crankshaft, until the connecting rod bearing cap to be removed comes at the oil pan side.
- (2) Slacken the connecting rod bearing cap nuts evenly over two or three stages. Then, remove the connecting rod bearing cap nuts.

NOTE:

Use the following SST to prevent the crankshaft from turning.

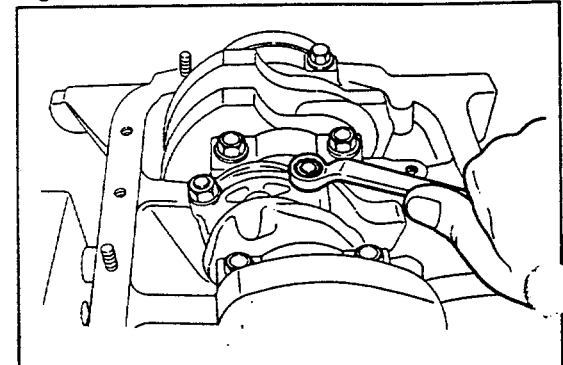

Fig. 5-234

WM-05274

SST: 09210-87701-000

(3) Remove the connecting rod bearing cap.

NOTE:

- ① Arrange the removed connecting rod bearing caps in order so that their installation positions may be known readily.
- ② Never touch the surface of the bearing by hands.
- ③ Be very careful not to scratch the crankshaft by the connecting rod bolts.

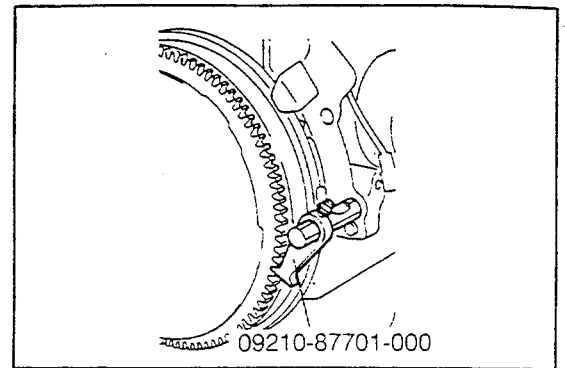

Fig. 5-235

WM-05275

19. Removal of connecting rod bearings

Remove the connecting rod bearing, as follows: Push the connecting rod bearing at the side without the turning-preventive tang by your finger so that the opposite end may float. Thus, take out the bearing. Do not touch the front surface and the back surface of the bearing by your finger during the removal.

NOTE:

- ① Arrange the removed connecting rod bearings in order so that their installation positions may be known readily.
- ② Be very careful not to scratch the front surface or back surface of the bearings.
- ③ Never touch the front surface or back surface of the bearings by hands.

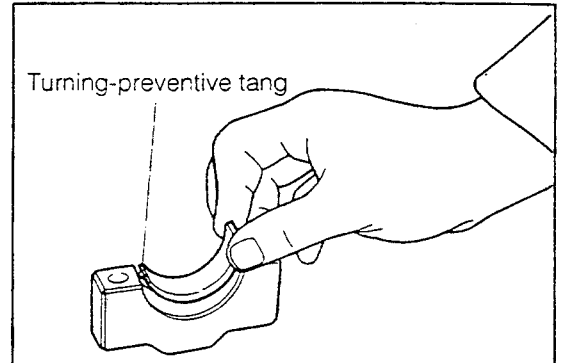

Fig. 5-236

WM-05276

20. Removal of connecting rod with piston

- (1) If the upper part of the cylinder block exhibits carbon deposits, forming ridges, remove them with a ridge reamer or the like.
- (2) Draw the connecting rod with the piston to the cylinder head side.

NOTE:

- ① Be very careful not to scratch the cylinder wall surfaces, crankshaft journals and connecting rod.
- ② Arrange the removed connecting rods with the pistons in order so that their installation positions may be known readily.

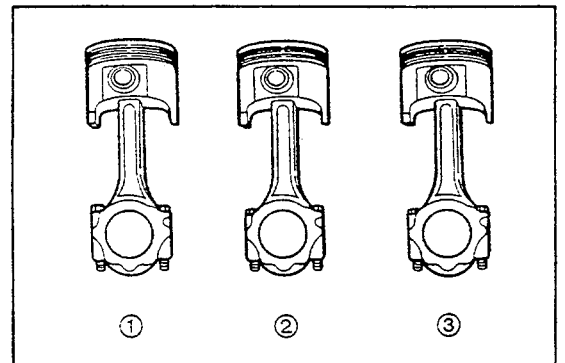

Fig. 5-237

WM-05277

21. Removal of flywheel

- (1) Slacken the attaching bolts of the flywheel evenly over two or three stages. Then, remove the bolts.
- (2) Remove the flywheel.

NOTE:

Care must be exercised as to its handling because the flywheel is heavy.

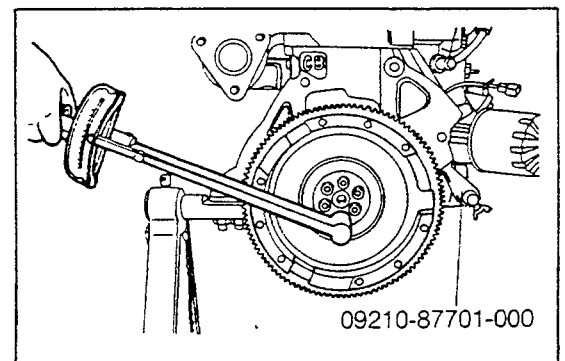

Fig. 5-238

WM-05278

ENGINE MECHANICALS

22. Remove the rear end plate.
23. Remove the oil seal retainer with the oil seal.
24. Remove the gasket.
25. Remove the balance shaft rear cover.
26. Remove the balance shaft rear cover gasket.
27. Removal of crankshaft bearing caps
 - (1) Slacken the crankshaft bearing cap bolts evenly over two or three stages. Then, remove the bolts.
 - (2) Remove the crankshaft bearing caps.

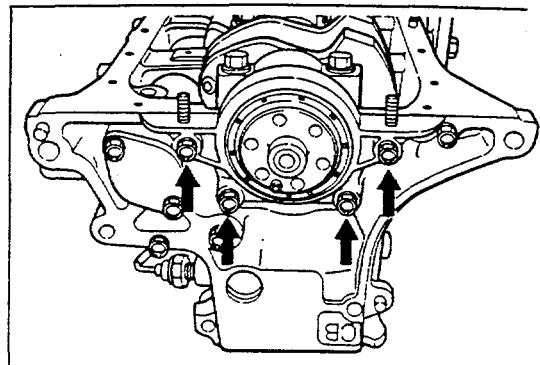

Fig. 5-239

WM-05279

28. Removal of crankshaft bearing (lower)

Remove the connecting rod bearing, as follows: Push the connecting rod bearing at the side without the turning-preventive tang by your finger so that the opposite end may float. Thus, take out the bearing. Do not touch the front surface or the back surface of the bearing by your finger during the removal.

NOTE:

Arrange the removed bearings in order so that their installation positions may be known readily.

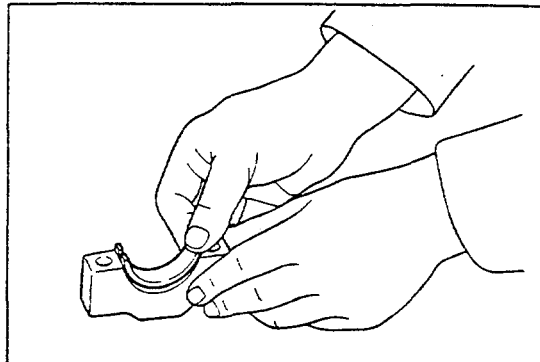

Fig. 5-240

WM-05280

29. Removal of crankshaft

Remove the crankshaft by lifting it vertically so that no scratch may be made to the crankshaft journals and the crankshaft may not interfere with the cylinder block.

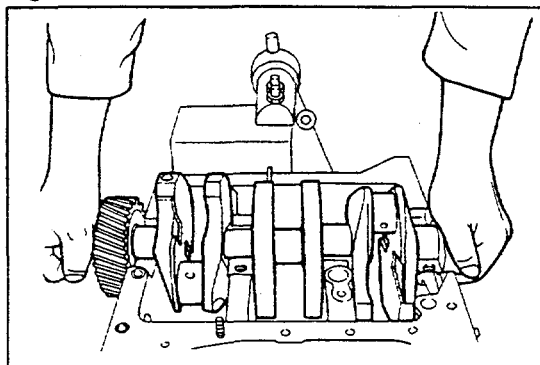

Fig. 5-241

WM-05281

30. Remove the thrust washers.

The thrust washers are provided at both sides of the bearing No.3.

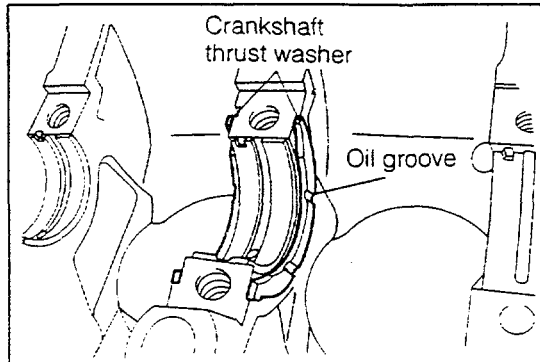

Fig. 5-242

WM-05282

31. Removal of crankshaft bearing (lower)

Remove the connecting rod bearing, as follows: Push the connecting rod bearing at the side without the turning-preventive tang by your finger so that the opposite end may float. Thus, take out the bearing. Do not touch the front surface or the back surface of the bearing by your finger during the removal.

NOTE:

- ① Arrange the removed bearings in order so that their installation positions may be known readily.
- ② Clean the disassembled parts with a cleaning solvent. Blow them by compressed air. This note does not apply to the rubber parts.

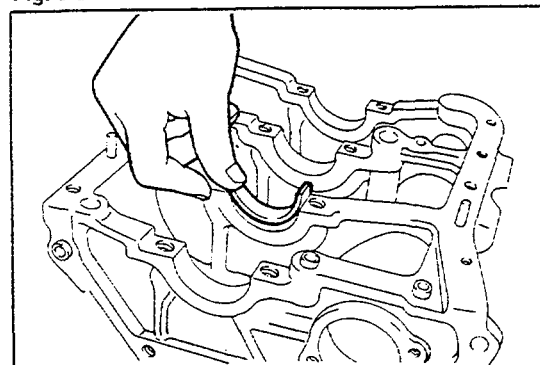

Fig. 5-243

WM-05283

Remove the cylinder block from the SST.

WM-05284

INSPECTION

1. Checking of cylinder block
 - (1) Check the cylinder block for damage or cracks.
 - (2) Check the cylinder head gasket surface for distortion.

NOTE:

Perform the measurement in six directions.

Maximum distortion limit: 0.1 mm (0.0039 inch)

[CB-23 engine only]

If the distortion exceeds the maximum distortion limit, recondition the surface. However, this reconditioning should not be performed beyond the grinding limit of 0.3 mm (0.012 inch).

Furthermore, make sure that the width between the cylinder head gasket contact surface and the oil pan attaching surface is at least 200.55 mm (7.896 inches).

- (3) Measure the cylinder bore diameters.

Measure the bore diameter of each cylinder. The measurement should be made at six points.

 - ① Ensure that the difference between the maximum and minimum bore diameters of each cylinder is within 0.1 mm (0.039 inch).

NOTE:

The measurement results should be recorded.

- ② If the difference between the maximum and minimum values exceeds the specified value (0.1 mm or 0.039 inch), perform boring and honing for the cylinder.

Specified cylinder bore diameter after honing

When repaired standard piston is used:	76.00 - 76.03 mm (2.992 - 2.993 inch)
When O/S 0.25 piston is used:	76.25 - 76.28 mm (3.002 - 3.003 inches)
When O/S 0.50 piston is used:	76.50 - 76.53 mm (3.012 - 3.013 inches)

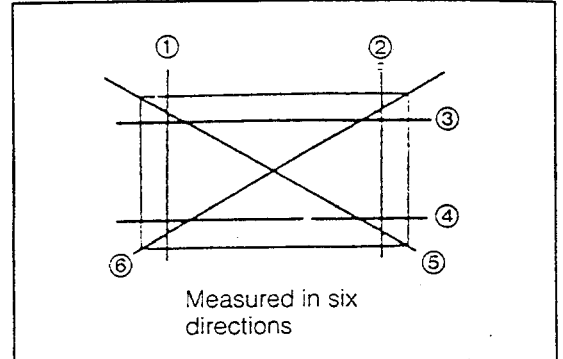

Fig. 5-244

WM-05285

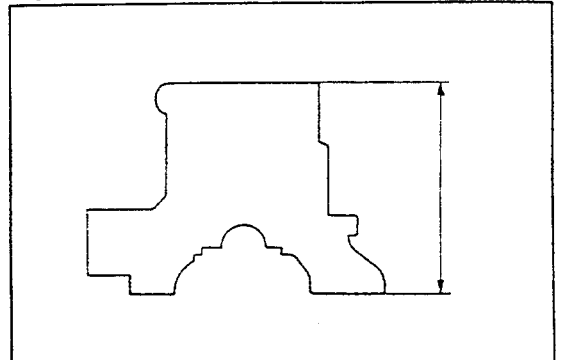

Fig. 5-245

WM-05286

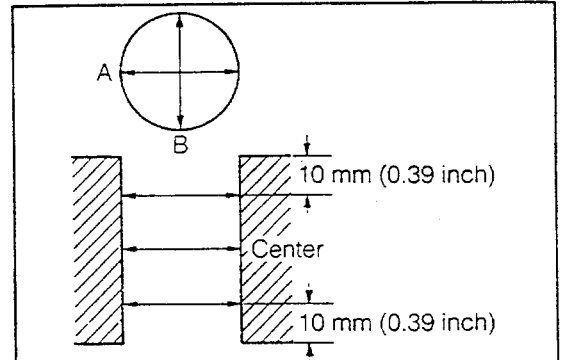

Fig. 5-246

WM-05287

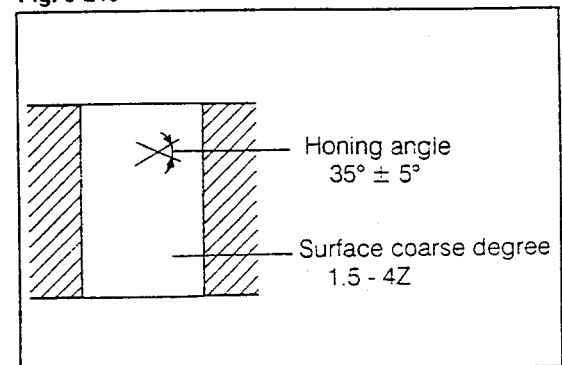

Fig. 5-247

WM-05288

ENGINE MECHANICALS

- ③ After the cylinder block has been cleaned and checked, calculate the cylinder-to-piston clearance: At this calculation, use the minimum measurement value as the cylinder bore diameter of each cylinder.

Cylinder-to-piston clearance:

0.03 - 0.12 mm (0.0012 - 0.0047 inch)

NOTE:

If the calculated clearance exceeds the specified value, perform boring and honing, referring to the specifications in ②. However, if the oversize pistons have been installed and the cylinder-to-piston clearance has exceeded the specified value, replace the cylinder block and pistons.

2. Checking of piston and piston rings

- (1) Remove the piston rings No.1 and No.2, using a commercially-available piston ring expander or the like.

NOTE:

- ① Arrange the removed piston rings in order so that their installation positions may be known readily.
② Do not expand the piston ring unnecessarily beyond the required extent.

- (2) Remove the oil ring by hand.

NOTE:

- ① Arrange the removed oil rings in order so that their installation positions may be known readily.
② Do not expand the oil ring unnecessarily beyond the required extent.
③ Disassemble the piston pin from the piston, using the following SST.

SST: 09221-25018-000

- ① Assemble the spring to the main body of the SST.
② Attach the smaller bar on the spring. While pushing the lever into the body, install the fitting piece to the main body, with the surface having a cut-out section facing upward. Then, secure it with the attaching screw.
③ Place the piston on the fitting piece, aligning the cut-out sections.
④ Install the longer lever into the piston hole.
⑤ Press off the piston pin, using a press.

NOTE:

Arrange the disassembled pistons and piston pins in order so that their installation positions may be known readily.

WM-05289

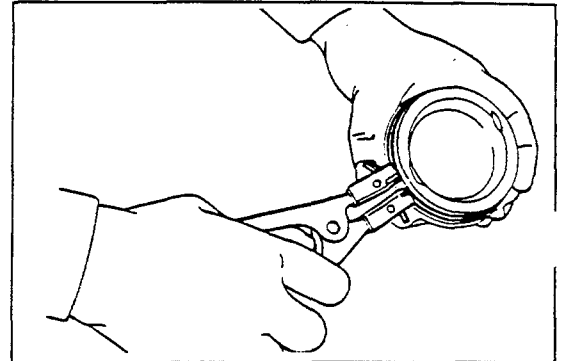

Fig. 5-248

WM-05290

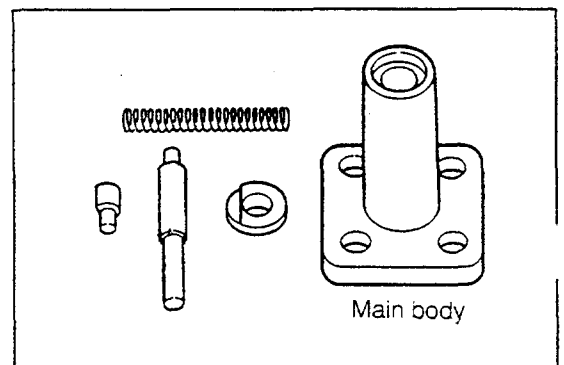

Fig. 5-249

WM-05291

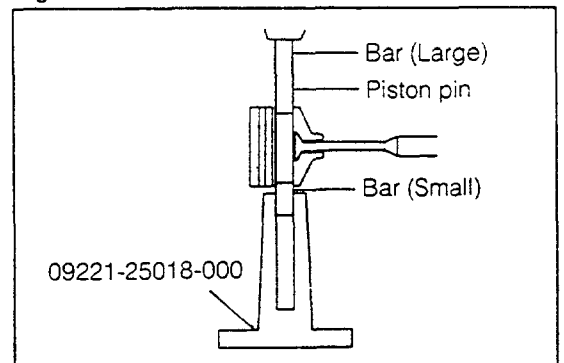

Fig. 5-250

WM-05292

- (4) Cleaning of pistons
- ① Remove the carbon deposits from the piston top, using a gasket scraper or the like.
 - ② Clean the piston ring groove with a broken piston ring or a groove cleaning tool.
 - ③ Clean the piston with a soft brush and a cleaning solvent.

NOTE:

Be very careful not to scratch the piston.

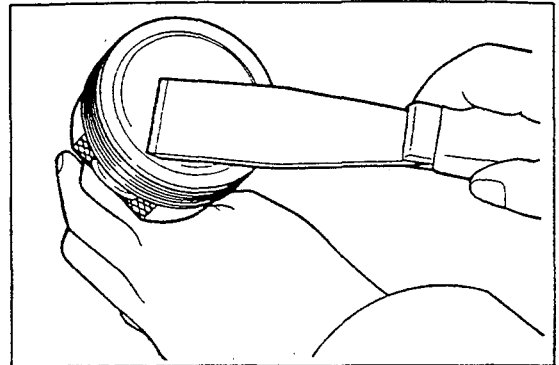

Fig. 5-251

WM-05293

- (5) Check the pistons for cracks, damage or seizure.
- (6) Checking piston ring side clearance
Check the piston ring side clearance over the entire periphery of each groove, using a filler gauge or a thickness gauge.
The maximum value in the measurement is regarded as the side clearance.

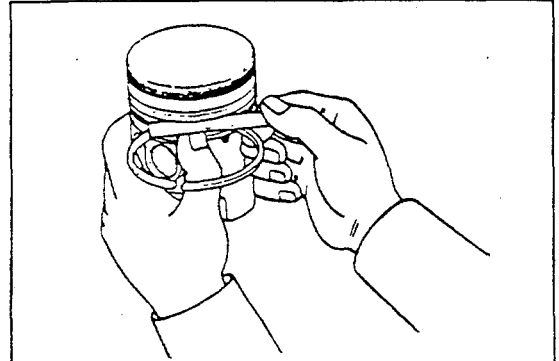

Fig. 5-252

WM-05294

Side clearance mm (inch)

	CB-23 & CB-61 engines	CB-80 engine
Compression ring No.1	0.03 - 0.12 (0.0012 - 0.0047)	0.05 - 0.12 (0.0002 - 0.0047)
Compression ring No.2	0.02 - 0.12 (0.0008 - 0.0047)	0.02 - 0.12 (0.0008 - 0.0047)

If the measured side clearance exceeds the specified value, measure the piston ring thickness with a micrometer. To make the side clearance meet the specifications, replace the piston ring or the piston, or both of them, referring to the piston ring standard thicknesses given below.

Piston ring standard thickness mm (inch)

	CB-23 & CB-61 engines	CB-80 engine
Compression ring No.1	1.47 (0.058)	1.47 (0.058)
Compression ring No.2		

WM-05295

- (7) Check the oil ring for damage.

NOTE:

If any of the ring No.1, ring No.2 and oil ring is defective, replace all of them as a set for one cylinder.

WM-05296

ENGINE MECHANICALS

(8) Measuring outer diameter of piston

Measure the outer diameter of the piston at the specified measuring point from the lower end of the piston.

Measuring points of piston outer diameter mm (inch)

	Measuring point
CB-23 & CB-61 engines	15 (0.6) from lower end
CB-80 engine	10 (0.4) from lower end

NOTE:

The measurement results should be recorded.

(The measurement results become necessary when the cylinder-to-piston clearance is calculated.)

(9) Checking piston pin oil clearance

- ① Measure the diameter of the piston pin hole.
- ② Measure the outer diameter of the piston pin.
- ③ Measure the piston-to-piston pin oil clearance.

Allowable limit: 0.03 mm (0.0018 inch)

NOTE:

If the oil clearance exceeds the specified value, replace the piston and piston pin as a set.

(10) Checking piston ring end gap

After the cylinder has been checked or reconditioned, insert the piston ring into the cylinder bore down to a point about 110 mm (4.3 inches) measured from the cylinder head gasket attaching surface. Then, measure the piston ring end gap.

NOTE:

Apply engine oil to the piston ring before inserting it.

End gap

[CB-23 & CB-61 engines]

Compression ring No.1

0.20 - 0.70 mm (0.079 - 0.028 inch)

Compression ring No.2

0.20 - 0.70 mm (0.079 - 0.028 inch)

Oil ring 0.20 - 1.10 mm (0.079 - 0.043 inch)

[CB-80 engine]

Compression ring No.1

0.35 - 0.70 mm (0.014 - 0.028 inch)

Compression ring No.2

0.28 - 0.70 mm (0.011 - 0.028 inch)

Oil ring 0.20 - 1.10 mm (0.008 - 0.043 inch)

If the end gap exceeds the specified limit, replace piston ring as a set.

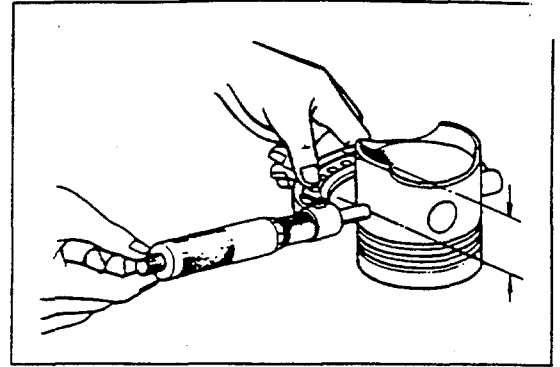

Fig. 5-253

WM-05297

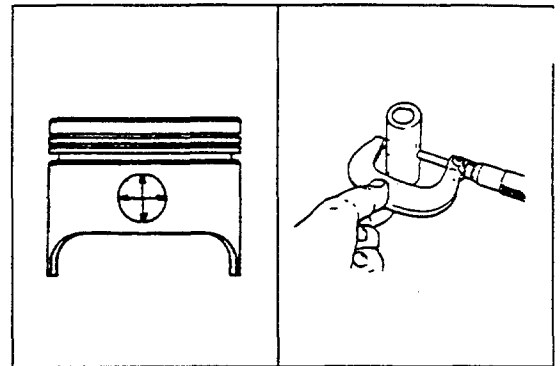

Fig. 5-254

WM-05298

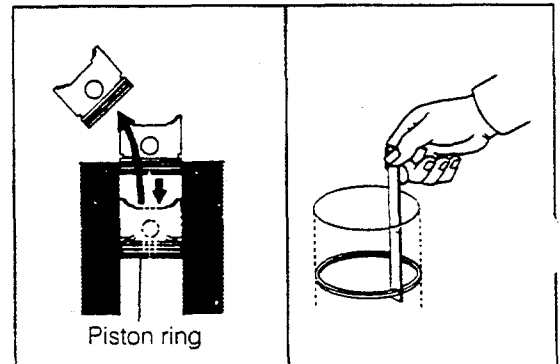

Fig. 5-255

WM-05299

Checking connecting rod

- (1) Check the connecting rod for damage or cracks.
- (2) Check the connecting rod for bend or twist.
 - Maximum bend limit: 0.05 mm (0.0020 inch)
 - Maximum twist limit: 0.05 mm (0.0020 inch)

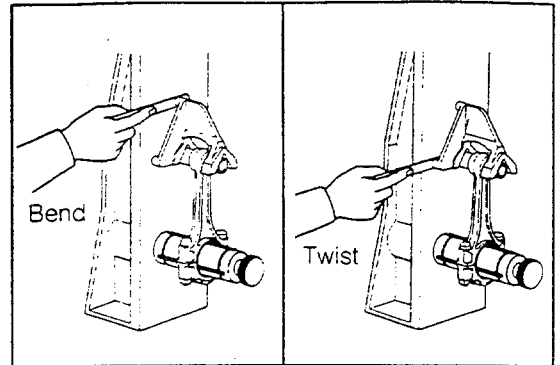

Fig. 5-256

WM-05300

- (3) Measure the oil clearance at the big end.
 - ① Install the bearing to the connecting rod and bearing cap.

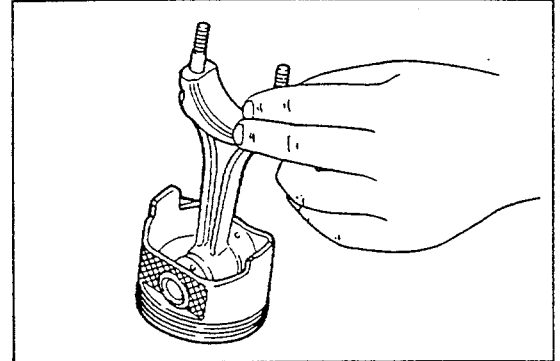

Fig. 5-257

WM-05301

- ② Install the plastigage on the crankpin journal. Tighten the bearing cap to the specified torque.

Tightening Torque:

kg-m (ft-lb)

CB-23 & CB-61 engines	2.5 ± 0.4 (18 ± 3)
CB-80 engine	4.7 ± 0.5 (34 ± 7)

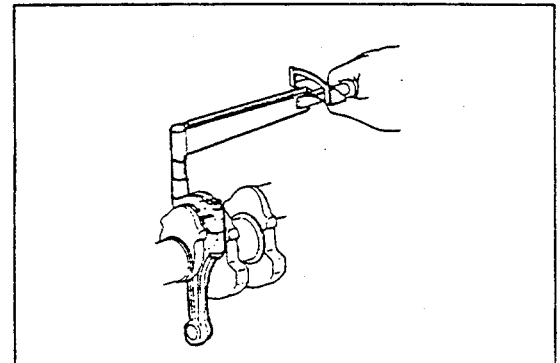

Fig. 5-258

WM-05302

- ③ Remove the bearing cap. Measure the oil clearance.
 - Oil clearance
 - [CB-23 & CB-61 engines]
 - 0.020 - 0.070 mm (0.00079 - 0.00280 inch)
 - [CB-80 engine]
 - 0.024 - 0.070 mm (0.00094 - 0.00280 inch)

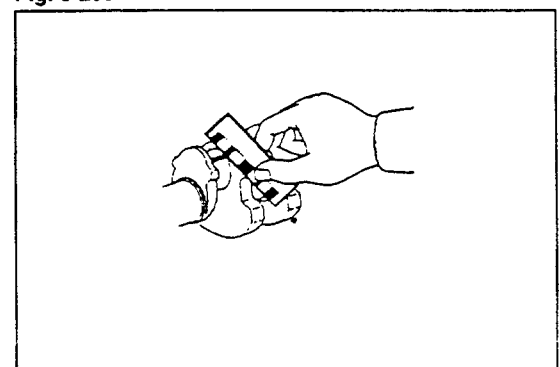

Fig. 5-259

WM-05303

If the oil clearance exceeds the specified value, grind or replace the crankshaft so that the oil clearance may meet the specifications, referring to the dimensions of the crankpin journal given below.

ENGINE MECHANICALS

mm (inch)

Bearing size	Crankpin journal diameter		
	Engine type		
	CB-23	CB-61	CB-80
Repair standard	39.958 - 39.992 (1.573 - 1.574)	39.958 - 39.992 (1.573 - 1.574)	42.962 - 42.992 (1.691 - 1.692)
U/S 0.25	39.734 - 39.742 (1.564 - 1.565)	—	42.738 - 42.742 (1.682 - 1.683)
U/S 0.50	39.484 - 39.492 (1.554 - 1.555)	—	42.488 - 42.492 (1.672 - 1.673)

NOTE:

- ① When grinding the crankpin journal, finish each crankpin journal should be finished so that its radius at the corner becomes 0.25 mm.
- ② On Type CB-61 engine, no undersize bearing is available.

WM-053

- ④ Checking connecting rod thrust clearance
Measure the thrust clearance between the connecting rod and the crankshaft, using a thickness gauge.

Thrust clearance

[CB-23 Engine]

0.15 - 0.38 mm (0.0059 - 0.0150 inch)

[CB-61 Engine]

0.15 - 0.38 mm (0.0059 - 0.0150 inch)

[CB-80 Engine]

0.15 - 0.45 mm (0.0059 - 0.0177 inch)

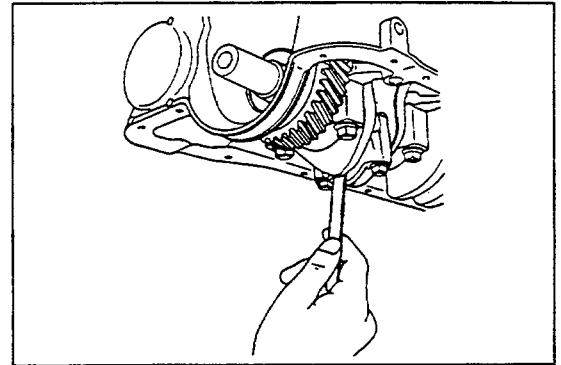

Fig. 5-260

WM-05305

NOTE:

The thrust clearance should be measured while the connecting rod being pushed against either side of the crankshaft in the axial direction. Measure the clearance at the opposite side.

- ⑤ If the clearance exceeds the specified value, replace the connecting rod or the crankshaft, or both of them, referring to the width of the big end of the connecting rod in the thrust direction and the side width of the crankpin journal.

mm (inch)

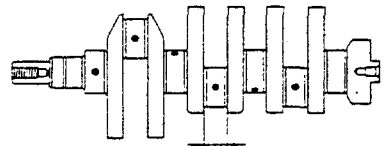
	Width of big end of connecting rod in thrust direction	Side width of crankpin
CB-23	21.80 - 21.85 (0.858 - 0.860)	22.00 - 22.13 (0.866 - 0.871)
CB-61	21.80 - 21.85 (0.858 - 0.860)	22.00 - 22.13 (0.866 - 0.871)
CB-80	24.80 - 24.85 (0.976 - 0.978)	25.0 - 25.2 (0.984 - 0.992)
Reference		

WM-05306

4. Checking of crankshaft

(1) Checking crankshaft for runout

- ① Measure the crankshaft runout at the main bearing journal No.3.

Maximum runout limit: 0.06 mm (0.0024 inch)

NOTE:

Be very careful not to scratch the crankshaft journals.

(2) Checking crankshaft for wear

Check the crankshaft main bearing journals and crankpin journals for evidence of seizure or scratches.

(3) Checking crankshaft main bearing journals and crankpin journals

Measure the outer diameter at four points of each of the main bearing journals and crankpin journals. This measurement should be conducted over the entire periphery of each journal, avoiding the oil holes provided on the journals.

Calculate the difference between the maximum value and minimum value for each measurement of the main bearing journals and crankpin journals.

Out-of-roundness and taper limit:

0.01 mm (0.0004 inch)

NOTE:

- ① The measurement results should be recorded.
- ② Be careful not to scratch the crankshaft.

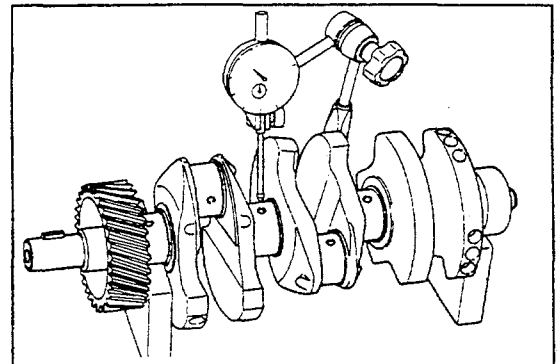

Fig. 5-261

WM-05307

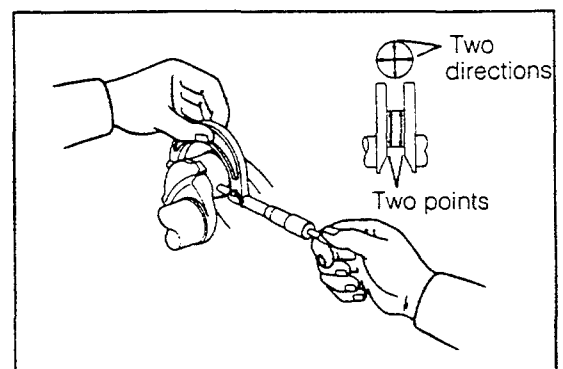

Fig. 5-262

WM-05308

ENGINE MECHANICALS

(4) Checking main bearing journal oil clearance

- ① Install the bearings in the cylinder block and main bearing caps. Do not touch the front surface or the back surface of the bearings and also the bearing installation surfaces of the cylinder block and bearing cap during the check.

NOTE:

Care must be exercised not to mistake the installation position of the upper bearing for that of the lower bearing.

Upper bearing (cylinder block side) A groove is provided.

Lower bearing (bearing cap side) No groove is provided.

WM-05309

② Install the crankshaft in the cylinder block.

NOTE:

- ① Be careful not to scratch the crankshaft and bearing.
- ② Do not apply engine oil to the crankshaft and bearings.

③ Install the plastigage.

④ Tighten the bearing cap to the specified torque.

Tightening Torque:

kg-m (ft-lb)

CB-23 & CB-61 engines	5.4 - 6.6 (40 - 48)
CB-80 engine	6.4 - 7.6 (46 - 55)

⑤ Remove the bearing cap. Take the reading of the oil clearance.

Main bearing journal oil clearance:

0.020 - 0.070 mm (0.0008 - 0.0028 inch)

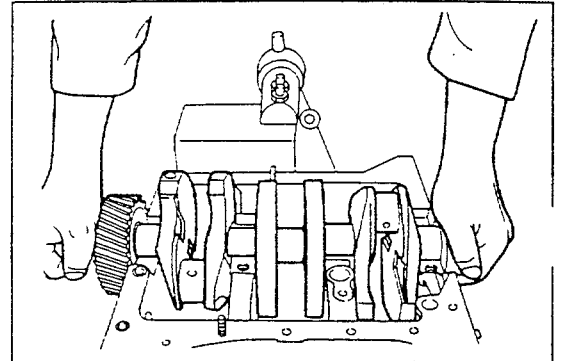

Fig. 5-263

WM-05310

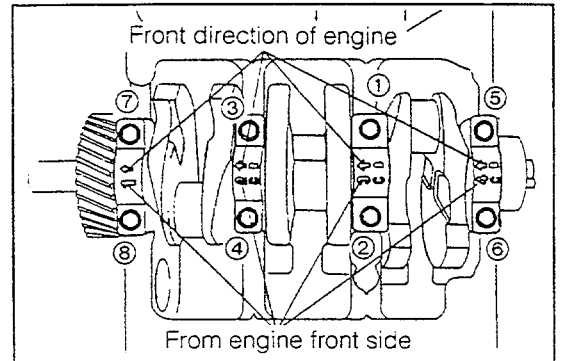

Fig. 5-264

WM-05311

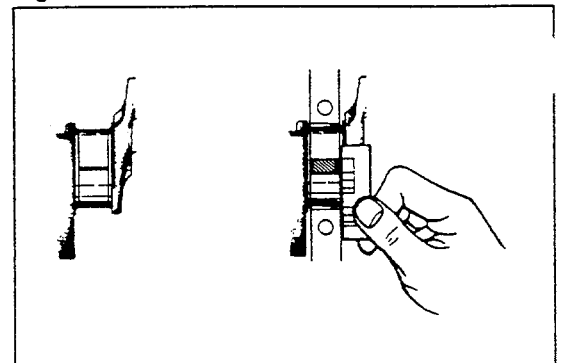

Fig. 5-265

WM-05312

- ⑥ If the oil clearance exceeds the specified value, grind or replace the crankshaft so that the oil clearance may meet the specifications, referring to the diameters of the main bearing journals given below.

mm (inch)

Bearing size	Main bearing journal diameter		
	Engine type		
	CB-23	CB-61	CB-80
Repair standard	41.958 - 41.992 (1.652 - 1.653)	41.958 - 41.992 (1.652 - 1.653)	47.962 - 47.992 (1.888 - 1.889)
U/S 0.25	41.734 - 41.742 (1.6430 - 1.6434)	—	—
U/S 0.50	41.484 - 41.492 (1.633 - 1.634)	—	—

NOTE:

- ① When grinding the main bearing journal, finish each main bearing journal so that its radius at the corner becomes 0.25 mm. (CB-23 engine only)
- ② On Type CB-61 and CB-80 engines, no undersize bearing is available.

WM-05313

(5) Checking crankshaft thrust clearance

- ① Install the bearings in the cylinder block and main bearing caps. Do not touch the front surface or the back surface of the bearings and also the bearing installation surfaces of the cylinder block and bearing cap during the check.

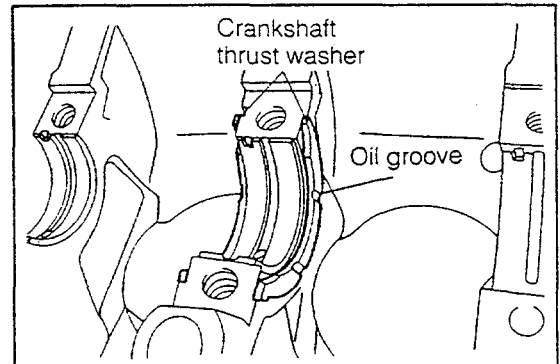

Fig. 5-266

WM-05314

- ② Install the thrust washers in the cylinder block.

NOTE:

Do not apply oil to the thrust washers.

- ③ Place the crank shaft to the cylinder block.

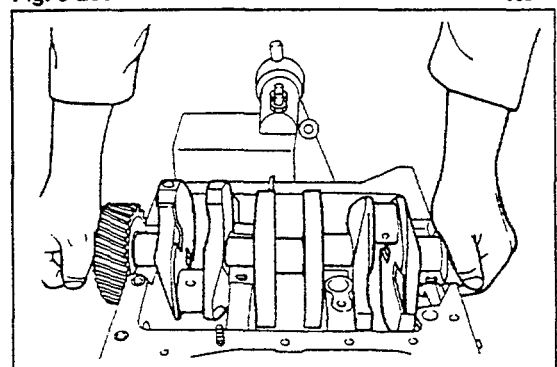

Fig. 5-267

WM-05315

- ④ Measure the thrust clearance, using a dial gauge.

Thrust Clearance:

0.02 - 0.30 mm (0.00079 - 0.01180 inch)

NOTE:

The measurement results should be recorded.

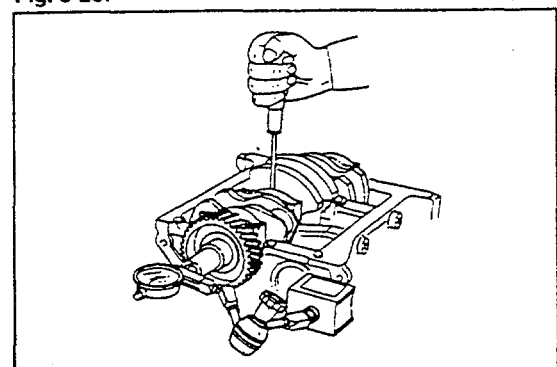

Fig. 5-268

WM-05316

ENGINE MECHANICALS

- ⑤ Remove the parts which have been assembled to the cylinder block.
- ⑥ If the thrust clearance exceeds the specified value, determine which thrust washers should be used or whether the crankshaft should be replaced, based on the following calculation.

Measured thrust clearance: A

Sum of thicknesses of thrust washers at right and left sides: B

Specified thrust clearance: C

Required thrust washer thickness: D

$$\{(A+B)-C\} \pm 2 = D$$

Based on the thus-calculated value D, select a suitable thrust washer from among those in the table below.

		mm (inc)
Thrust washer size	Thrust washer thickness	Remarks
Standard	1.940 - 1.990 (0.0764 - 0.0783)	To be used when the maximum value of D is 1.990 or less.
O/S 0.125	2.065 - 2.115 (0.0813 - 0.0833)	To be used when the maximum value of D exceeds 1.990.
O/S 0.25	2.190 - 2.240 (0.0862 - 0.0882)	To be used when maximum value of D exceeds 2.115.

WM-05318

[Example]

Measured thrust clearance: A = 0.53 mm

Sum of thicknesses of thrust washers at right and left sides: B = 3.80 mm

Specified thrust clearance: C = 0.02 to 0.30

Required thrust washer thickness: D = ?

$$D = \{(0.53+3.80)-C\} \pm 2$$

$$= 2.015 \text{ to } 2.115$$

In this case, use a O/S 0.125 mm thrust washer.

However, if the minimum value of D exceeds 2.240 mm (0.0882 inch), replace the crankshaft and thrust washer in a set.

[Reference]

Such determination can also be made by measuring the width of the thrust bearing contact surface of the crankshaft.

		mm (inch)
	Measurement value (A)	
Standard	23.000 - 23.130 (0.905 - 0.911)	
O/S 0.125	23.125 - 23.255 (0.910 - 0.916)	
O/S 0.25	23.25 - 23.38 (0.915 - 0.920)	
Replace crankshaft.	23.38 (0.920) or more	

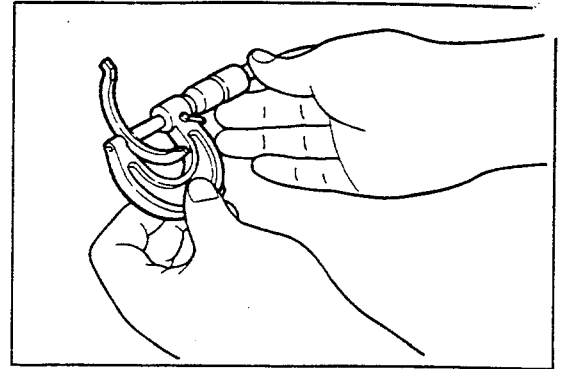

Fig. 5-269

WM-05317

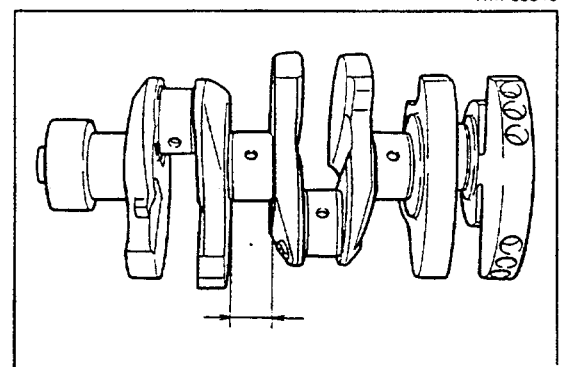

Fig. 5-270

WM-05319

Checking of balance shaft and gear

(1) Check the balance shaft and gear for damage, abnormal wear, cracks or seizure.

NOTE:

As for the disassembling procedure for the balance shaft and gear, see the sections (2) - ⑤ onward.

(2) Checking thrust clearance

① Attach the balance shaft to the cylinder block. Tighten the hexagon socket head cap bolt, using a hexagon wrench key (5 mm).

Tightening Torque: 1.25 ± 0.25 kg-m (9 ± 1.8 ft-lb)

NOTE:

Be sure to apply oil to the balance shaft bearing section.

② With a dial gauge attached at the forward end of the balance shaft at the balance shaft gear side, measure the thrust clearance of the balance shaft.

Thrust clearance:

0.03 - 0.20 mm (0.0012 - 0.0079 inch)

③ If the thrust clearance exceeds the specified value, replace the thrust washer with a new one. Then, measure the thrust clearance again.

Thrust clearance:

0.03 - 0.20 mm (0.0012 - 0.0079 inch)

NOTE:

As for the disassembling procedure for the balance gear and balance shaft, see section ⑤ onward.

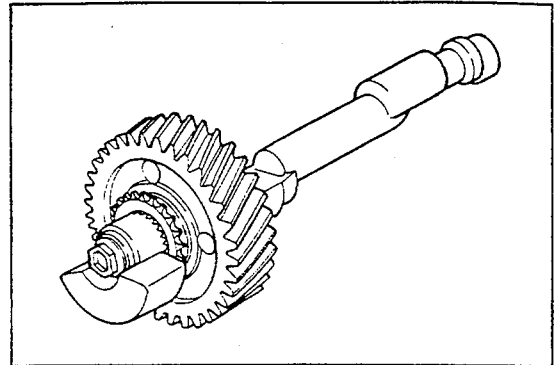

Fig. 5-271

WM-05321

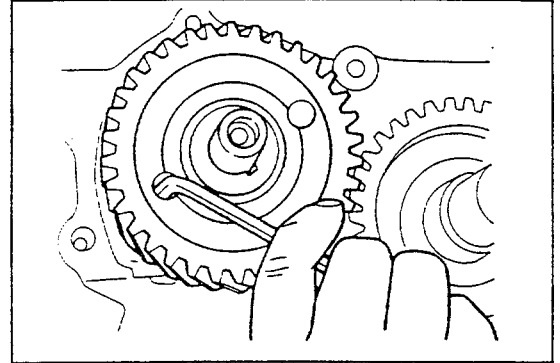

Fig. 5-272

WM-05322

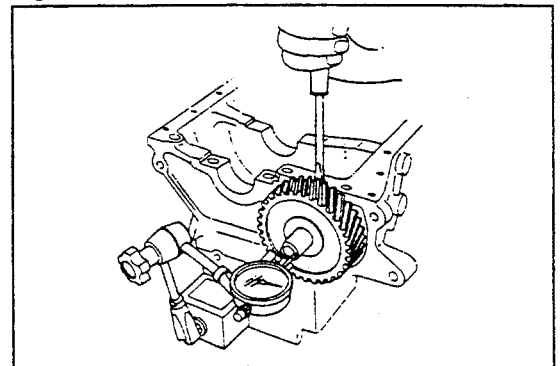

Fig. 5-273

WM-05323

④ If the thrust clearance still exceeds the specified value even after the new thrust washer has been assembled, replace the balance shaft with a new one.

NOTE:

As for the disassembling procedure for the balance gear and balance shaft, see section ⑤ onward.

WM-05324

ENGINE MECHANICALS

- ⑤ Disassembling balance shaft and balance shaft gear
Remove the balance shaft gear from the balance shaft, using the following SSTs.

SST: 09214-87701-000
09253-87202-000

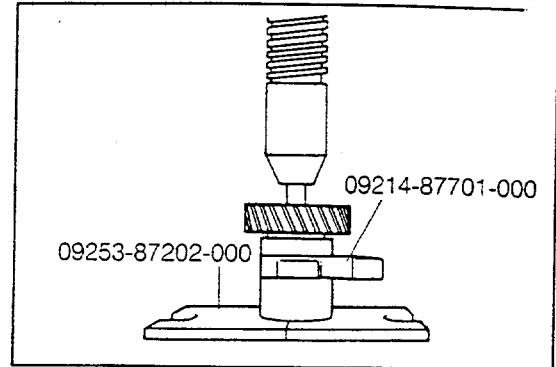

Fig. 5-274

WM-05325

- ⑥ Assembling balance shaft and balance shaft gear
Attach the thrust plate to the balance shaft. Press the balance shaft gear into position, using a press in combination with the following SSTs.

SST: 09214-87701-000
09253-87201-000
09506-87303-000

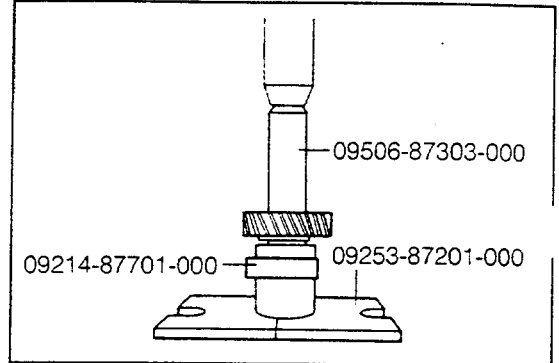

Fig. 5-275

WM-05326

- (3) Checking balance shaft for oil clearance

- ① Measure the outer diameters of the front and rear bearing journals of the balance shaft.

The measurement should be performed at the mid-point of each of the front and rear journals, in the two directions, 90 degrees apart from each other. The maximum value in the measurement is regarded as the outer diameter.

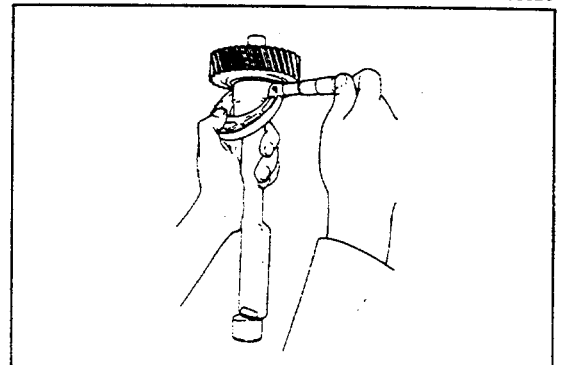

Fig. 5-276

WM-05327

- ② Measure the inner diameters of the bearing bores of the balance shaft.

The measurement should be performed at the mid-point of each of the front and rear bearing bores, in the two directions, 90 degrees apart from each other. The maximum value in the measurement is regarded as the inner diameter.

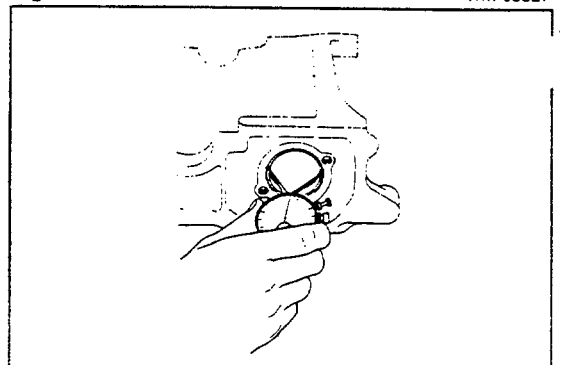

Fig. 5-277

WM-05328

- ③ Calculate the oil clearance.
Oil clearance: 0.25 - 0.1 mm (0.0098 - 0.0039 inch)
- ④ If the oil clearance exceeds the specified value, replace the balance shaft bearing and/or grind or replace the balance shaft so that the oil clearance may meet the specifications, referring to the diameters of the balance shaft bearing given below.

Balance shaft bearing sets

mm (inch)

Balance shaft bearing	Balance shaft bearing inner diameter	
	Front	Rear
Repair standard	44.925 - 44.975 (1.769 - 1.771)	33.925 - 33.975 (1.336 - 1.338)
U/S 0.5	44.425 - 44.475 (1.749 - 1.751)	33.425 - 33.475 (1.316 - 1.318)

WM-05329

- ⑤ Pull out the balance shaft bearing, using the following SST.
SST: 09215-87701-000

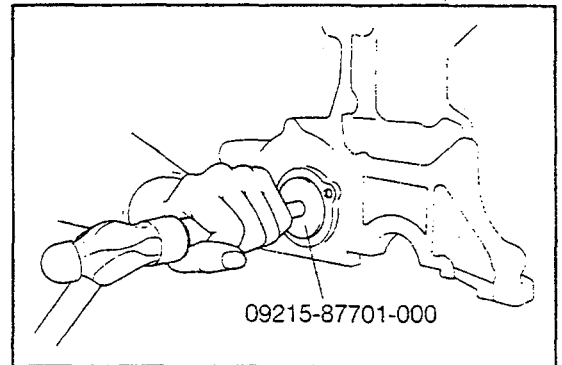

Fig. 5-278

WM-05330

- ⑥ Install the balance shaft bearing, using the following SST.
SST: 09215-87701-000

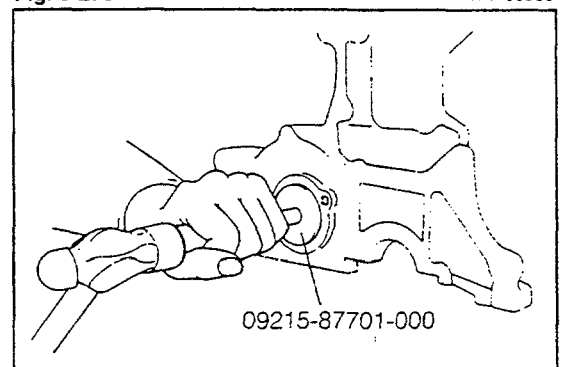

Fig. 5-279

WM-05331

NOTE:

- ① Be sure to install the bearing in the correct direction. Also, align the oil hole of the cylinder block with that of the bearing during the installation.
- ② After the bearing has been pressed into position, make sure that no burr or the like exists at the bearing bore. If the bearing exhibits any burr or the like, remove such harmful burrs, using an adjustable reamer.

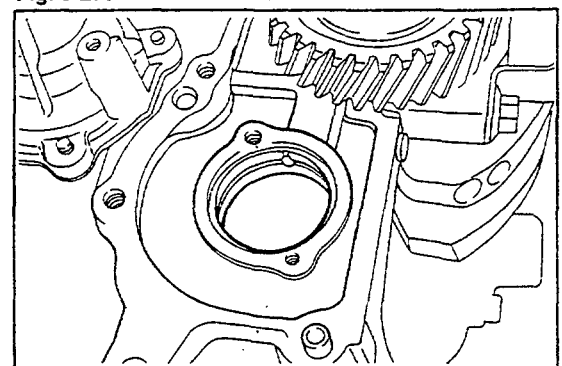

Fig. 5-280

WM-05332

ENGINE MECHANICALS

6. Checking of crankshaft balance shaft drive gear

(1) Check the crankshaft balance shaft drive gear for damage or wear. Replace it, as required.

WM-05333

(2) Remove the crankshaft balance shaft drive gear from the crankshaft, using the following SST.

SST: 09253-87202-000

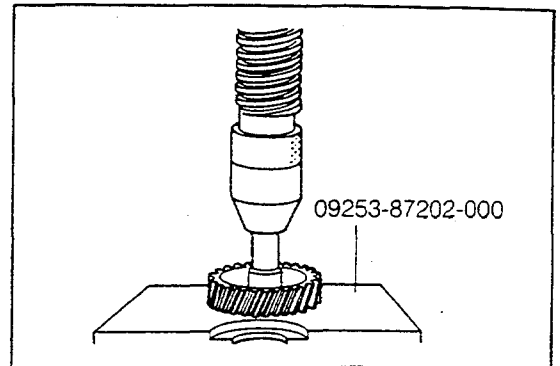

Fig. 5-281

WM-05334

(3) Install the crankshaft balance shaft drive gear to the crankshaft, using the following SSTs.

SST: 09506-87303-000

09253-87202-000

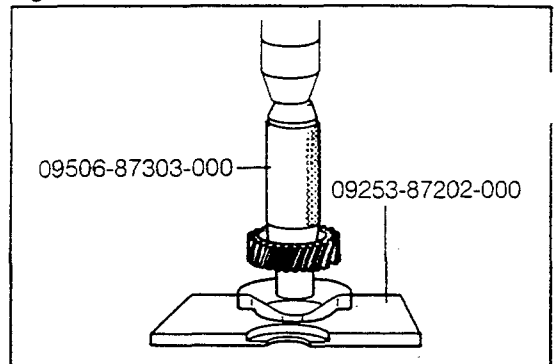

Fig. 5-282

WM-05335

NOTE:

Make sure that the key groove at the crankshaft side and the woodruff key exhibit no damage. The assembling should be made by aligning the woodruff key at the crankshaft with the key groove of the crankshaft balance shaft drive gear.

7. Checking of flywheel

(1) Checking flywheel for runout

① Tighten the flywheel to the specified torque.

Tightening Torque

kg-m (ft-lb)

CB-23 & CB-61 engines	4.0 - 5.0 (29 - 36)
CB-80 engine	6.0 - 7.0 (43 - 51)

NOTE:

Prior to the check, be sure that the crankshaft bearings have been tightened to the specified torque.

② Check the flywheel for runout with a dial gauge.

Runout limit of flywheel: 0.1 mm (0.0039 inch)

If the measured runout exceeds the limit, replace the flywheel.

(2) Ensure that the ring gear and clutch disc contact surface exhibit no wear or damage.

WM-05336

8. Checking of other parts

(1) Check the other parts for damage or cracks, etc. Replace the parts, as required.

(2) As for the oil pump check, see the section under "Unit Inspection" (page 7-3 to 7-5).

(3) As for the water pump check, see the section under "Unit Inspection".

WM-05

STALLATION

CAUTION

1. Clean all parts thoroughly.
2. Apply new engine oil to the sliding and rotating parts before assembling.
3. Replace all gaskets and "O" rings.
4. Use liquid packing as required to prevent water leakage and oil leakage.
5. Use the proper attaching bolts, nuts and washers. Tighten the nuts and bolts to the specified torque. Be very careful not to overtighten the studs installed to aluminum alloy parts.
6. When marks have been put during the disassembly, perform the reassembly in accordance with these marks. Confirm that the pistons and other parts are assembled correctly, meeting the specified clearance.

WM-05338

1. Install the cylinder block to the following SSTs.
 SSTs: 09219-87202-000
 09219-87701-000

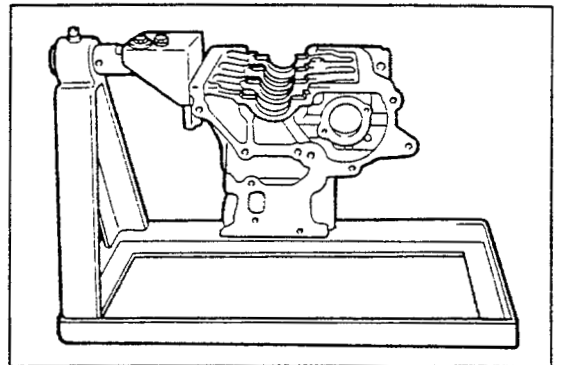

Fig. 5-283

WM-05339

2. Installation of crankshaft upper bearings
 - (1) Install the crankshaft upper bearings to the bearing sections of the cylinder block. Do not touch the front surface or back surface of the bearing and also the bearing installation surfaces of the cylinder block during the installation.
 - (2) Apply engine oil to the surfaces of the installed bearings.

NOTE:

Wipe off any oil on the back surface of each crankshaft bearing.

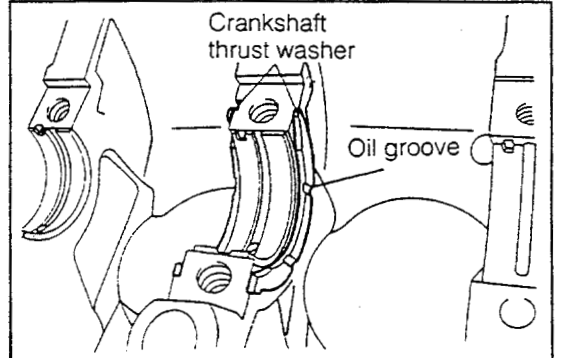

Fig. 5-284

WM-05340

3. Assembly of crankshaft

Apply engine oil to the crankshaft main bearing journals. Then, assemble the crankshaft in the cylinder block.

NOTE:

Be very careful not to scratch each of the crankshaft journals during the assembly.

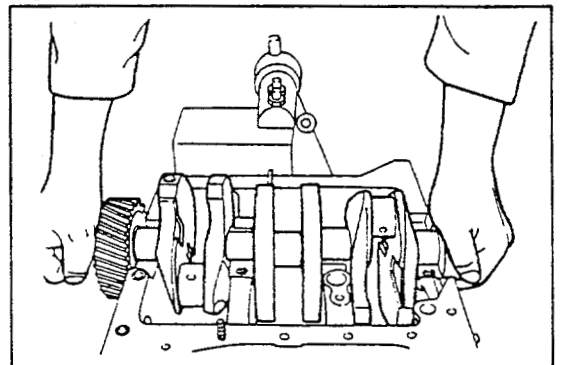

Fig. 5-285

WM-05341

ENGINE MECHANICALS

4. Assembly of thrust washers

Apply engine oil to the thrust washers. With the side having the oil groove facing toward the crankshaft, insert each washer between the cylinder block and the crankshaft.

NOTE:

The insertion position is the crankshaft main bearing journal No.3 at the upper side.

WM-05342

5. Installation of crankshaft lower bearings and crankshaft bearing caps

(1) Assemble the crankshaft lower bearing to each crankshaft bearing cap.

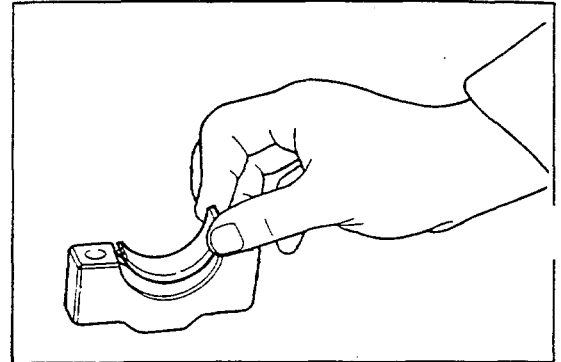

Fig. 5-286

WM-05343

(2) Liberally apply engine oil to each bearing surface. Then, install the bearing caps in the cylinder block.

NOTE:

- ① Be careful not to scratch each journal of the crankshaft.
- ② Install the bearing caps in such a way that the arrow mark provided on each bearing cap faces toward the front side of the engine.

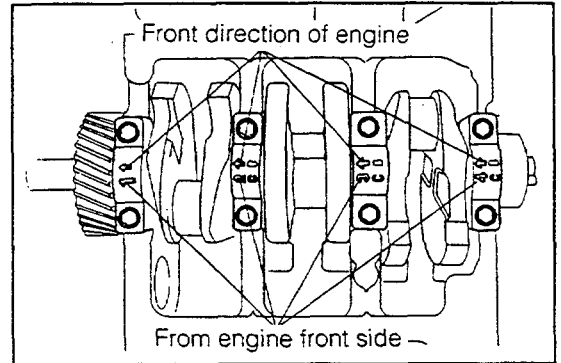

Fig. 5-287

WM-05344

(3) Tighten the crankshaft bearing caps to the specified torque in the sequence indicated in the right figure.

NOTE:

- ① After the bearing caps have been tightened temporarily, make sure that the crankshaft can be turned lightly. Then, each time the bearing cap is further tightened, make sure that the crankshaft still can be turned lightly.
- ② On Type CB-80 engine, the bracket oil nozzle No.1 and No.2 are tightened in common at the bearing caps No.1 and No.3.

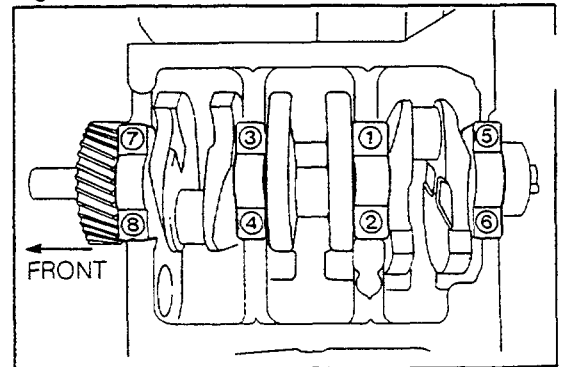

Fig. 5-288

WM-05345

Temporal Tightening Torque

kg-m (ft-lb)

CB-23 & CB-61 engines	2.5 - 3.5 (18 - 25)
CB-80 engine	5.0 - 5.5 (36 - 40)

Final Tightening Torque

kg-m (ft-lb)

CB-23 & CB-61 engines	5.4 - 6.6 (39 - 48)
CB-80 engine	6.4 - 7.6 (46 - 55)

Install the balance shaft rear cover gasket.

NOTE:

The gasket is a nonreusable part.

7. Install the balance shaft rear cover.

WM-05346

8. Install the oil seal retainer gasket.

NOTE:

The gasket is a nonreusable part.

9. Installation of oil seal retainer with oil seal

- (1) Drive a new oil seal into position, using the following SST.

SST: 09515-87301-000

- (2) Apply engine oil to the rear oil seal contact section of the crankshaft and the lip section of the oil seal. Then, install the oil seal retainer in the cylinder block.

10. Install the rear end plate.

Installation of flywheel

- (1) Attach the flywheel to the crankshaft rear end.
- (2) Tighten the bolts evenly over about two stages in the sequence indicated in the right figure.

Tightening Torque

kg-m (ft-lb)

CB-23 & CB-61 engines	4.0 - 5.0 (29 - 36)
CB-80 engine	6.0 - 7.0 (43 - 51)

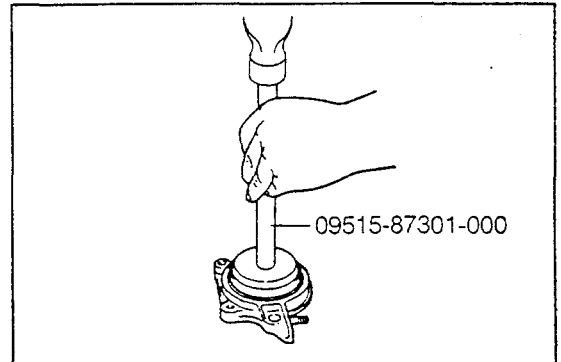

Fig. 5-289

WM-05347

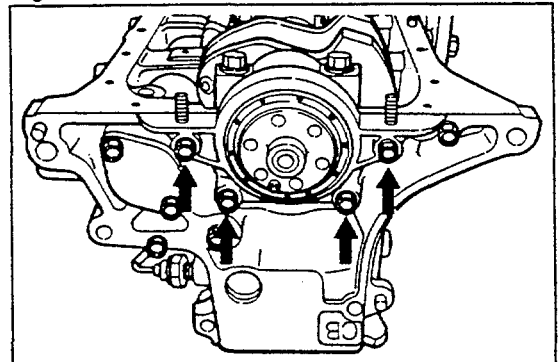

Fig. 5-290

WM-05348

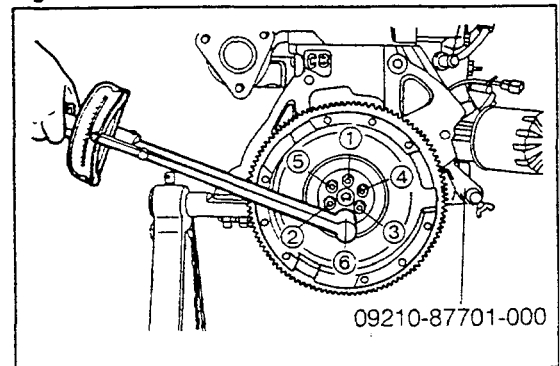

Fig. 5-291

WM-05349

ENGINE MECHANICALS

12. Assembly of connecting rod with lower bearing and piston

(1) Assemble the connecting rod and piston, using the following SST.

SST: 09221-25018-000

WM-05350

- ① Insert the spring into the main body.
- ② Insert the larger bar into the main body.
- ③ Install the fitting piece to the main body, with the side having a cut-out section facing upward.
- ④ Install the piston on the main body, aligning with the cut-out section of the fitting piece.

NOTE:

Apply engine oil to the piston pin hole.

- ⑤ Insert the piston pin into the piston pin hole.

NOTE:

Apply engine oil to the piston pin.

- ⑥ Insert the smaller bar into the piston pin.
- ⑦ Insert the small end of the connecting rod into the piston pin hole.

NOTE:

Align the front mark of the piston with the front mark of the connecting rod.

- ⑧ Press the piston pin by pressing the smaller bar mounted on the piston pin.

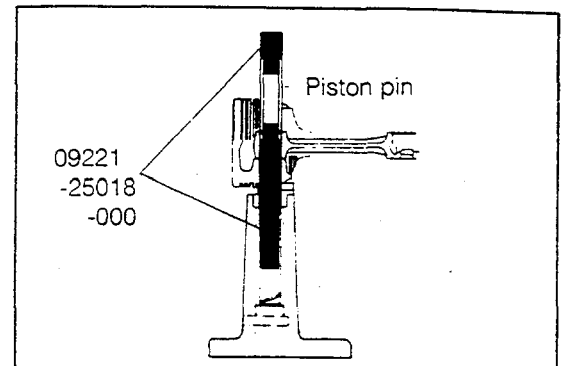

Fig. 5-292

WM-05351

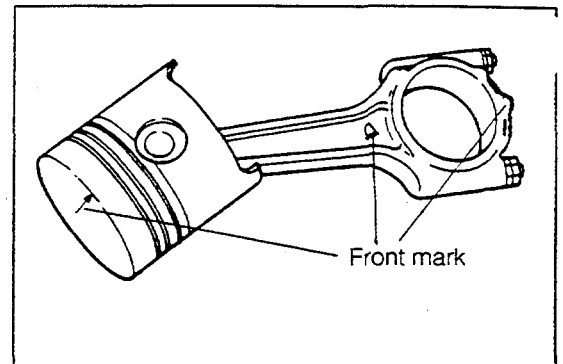

Fig. 5-293

WM-05352

(2) Assembling oil ring in piston

- ① Fit the expander spacer to the oil ring groove.

NOTE:

Install the expander spacer in such a way that spacer ends may not coincide with the front mark.

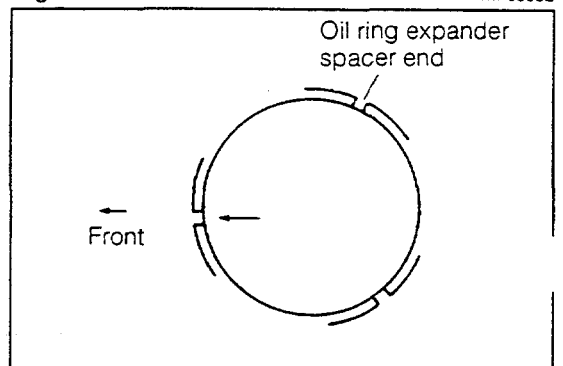

Fig. 5-294

WM-05353

② Assemble the upper rail.

NOTE:

- Be careful not to scratch the piston by the end of the rail.
- Set the rail in such a way that the ends of the rail are deviated to the left 90 degrees from that of the expander spacer.

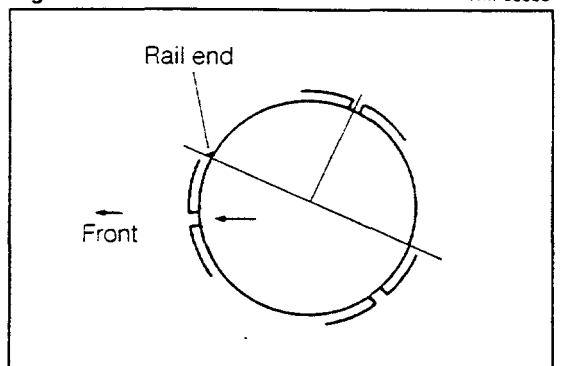

Fig. 5-295

WM-05354

- ③ Assemble the lower rail.

NOTE:

- Utmost care must be exercised not to scratch the piston by the end of the rail.
- Set the rail in such a way that the ends of the rail are deviated to the right 90 degrees from that of the expander spacer.

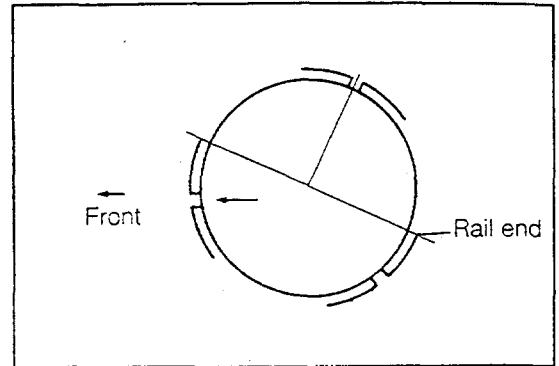

Fig. 5-296

WM-05355

- (3) Assemble the compression rings No.1 and No.2 in such a way that each end of the compression rings is 120 degrees apart from the end of the expander spacer of the oil ring in opposite directions from each other. In this way, make sure that no ends come in the same angle on the circumference of the piston.

NOTE:

Utmost care must be exercised not to scratch the piston by the end of the ring.

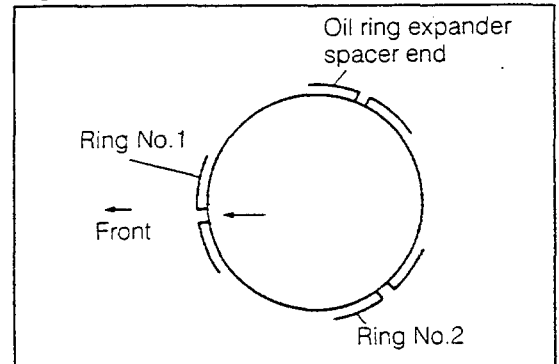

Fig. 5-297

WM-05356

- (4) Install the connecting rod upper bearing. Do not touch the upper bearing installation surface of the connecting rod and also the front surface or the back surface of the upper bearing during the installation.

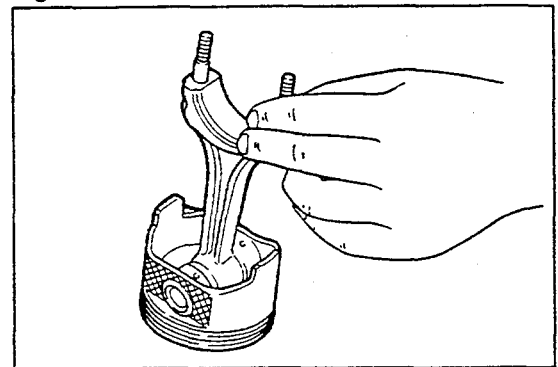

Fig. 5-298

WM-05357

- (5) Apply engine oil to the side wall of the piston, piston rings and piston pin.

NOTE:

Make sure that the ends of each ring does not move during this operation.

- (6) Apply engine oil to the cylinder wall, surface of the connecting rod upper bearing and crankpin journal.

WM-05358

- (7) Compress the piston rings, using a piston ring compressor. Then, assemble the piston into the cylinder bore.

SST: 09217-87701-000

NOTE:

- ① Be sure to install the piston in the correct direction, referring to the position of the front mark.
- ② Make sure that the ends of each ring does not move during the installation.
- ③ Care must be exercised to ensure that the crankshaft journal is not scratched by the connecting rod.

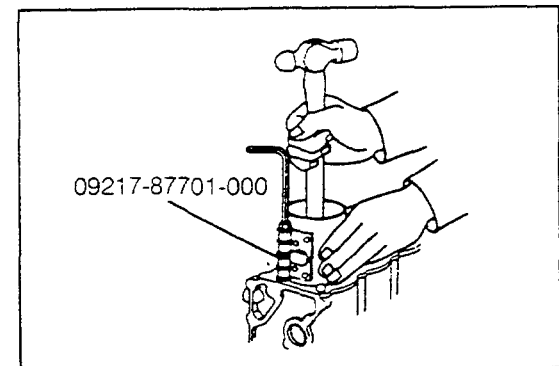

Fig. 5-299

WM-05359

ENGINE MECHANICALS

13. Assembling connecting rod bearing cap with lower bearing

- (1) Install the connecting rod lower bearing to the connecting rod bearing cap. Do not touch the lower bearing installation surface of the connecting rod bearing cap and also the front surface or the back surface of the lower bearing during the assembly.
- (2) Apply engine oil to the bearing surface.
- (3) Install the connecting rod bearing cap, with the front mark facing toward the front side of the engine.

Tightening Torque

kg-m (ft-lb)

CB-23 & CB-61 engines	2.1 - 2.9 (15 - 21)
CB-80 engine	4.2 - 5.2 (30 - 38)

NOTE:

- ① When tightening the connecting rod bearing cap, use the following SST to prevent the crankshaft from turning.
SST: 09210-87701-000

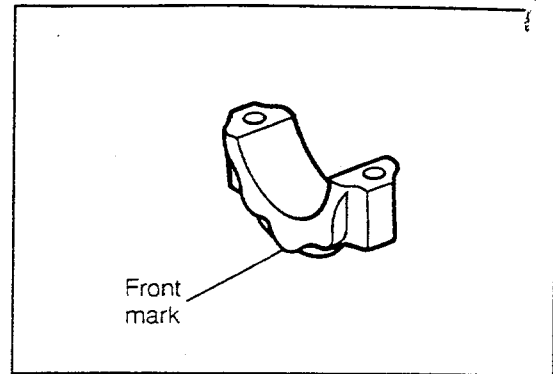

Fig. 5-300

WM-05360

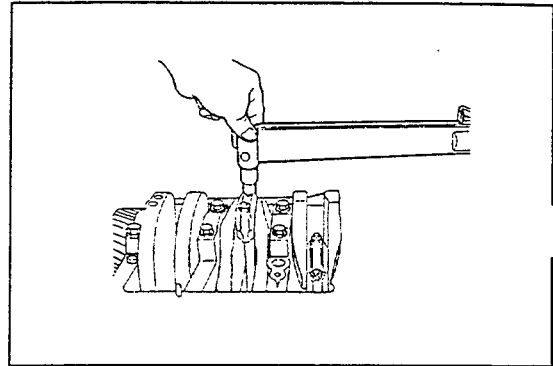

Fig. 5-301

WM-05361

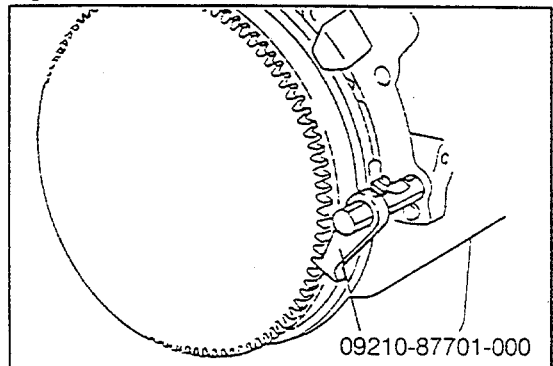

Fig. 5-302

WM-05362

14. Assembling Balance Shaft

- (1) Apply engine oil to the balance shaft bearing of the cylinder block.
- (2) Apply engine oil to the balance shaft bearing journals and thrust washer sections.

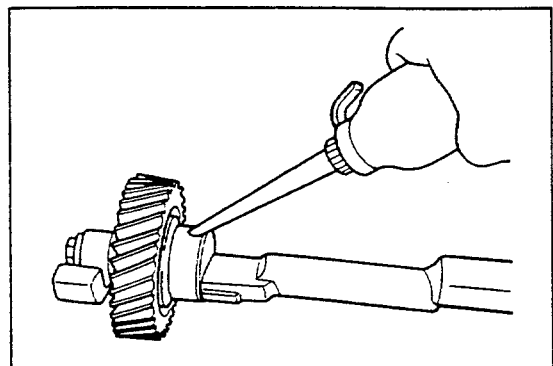

Fig. 5-303

WM-05364

- (3) Turn the crankshaft, until the stamped mark of the balance shaft drive gear of the crankshaft is aligned with the stamped mark of the balance shaft gear. Then, insert the balance shaft into position.

NOTE:

When the balance shaft is inserted, be careful not to damage the balance shaft bearing.

- (4) Install the thrust washer to the cylinder block by tightening the hexagon bolts.

NOTE:

Use a hexagon wrench key whose width across flats is 5 mm.

15. Install the oil pump drive sprocket to the balance shaft.

16. Install the balance weight to the balance shaft. Insert the washer and tighten the bolt.

NOTE:

When tightening the bolt, prevent the crankshaft from turning, using the following SST at the flywheel side.

SST: 09210-87701-000

17. Installation of oil pump with oil pump outlet pipe

- (1) Replace the "O" ring of the oil pump outlet pipe with a new one. Insert the oil pump outlet pipe into the oil pump, being careful not to damage the "O" ring.
- (2) Mount the oil pump with the oil pump outlet pipe on the cylinder block.
- (3) Insert the oil pump outlet pipe into the cylinder block, being careful not to damage the "O" ring.
- (4) Install the bolts to each bolt hole temporarily.

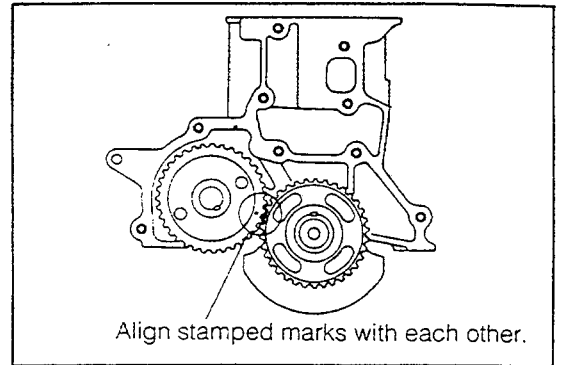

Fig. 5-304

WM-05365

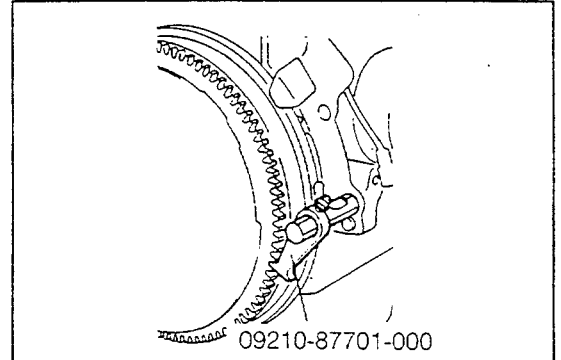

Fig. 5-305

WM-05366

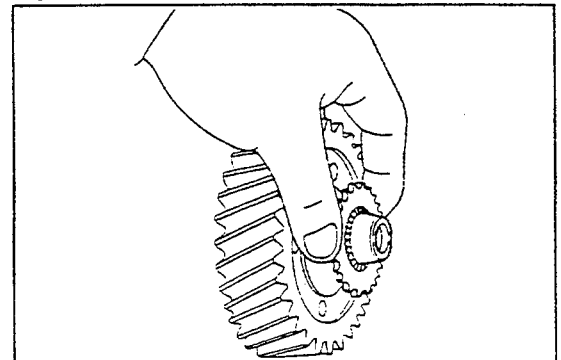

Fig. 5-306

WM-05367

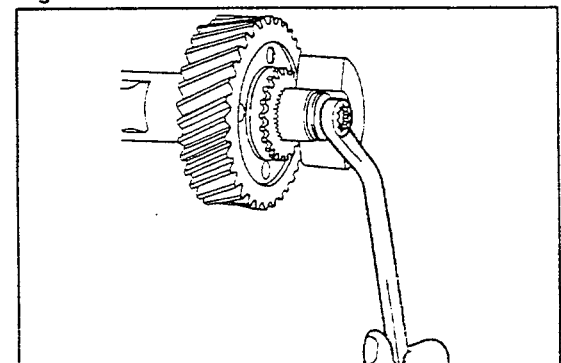

Fig. 5-307

WM-05368

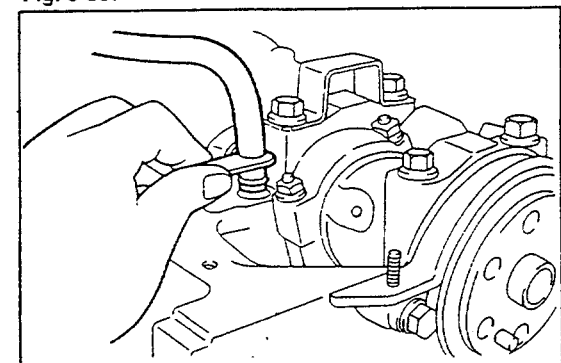

Fig. 5-308

WM-05369

ENGINE MECHANICALS

- (5) Tighten the attaching bolts of the oil pump outlet pipe. Ensure that no excessive force is applied to the connecting section with the oil pump.
- (6) Tighten the attaching bolts of the oil pump.
Tightening Torque: 1.5 - 2.2 kg-m (11 - 16 ft-lb)

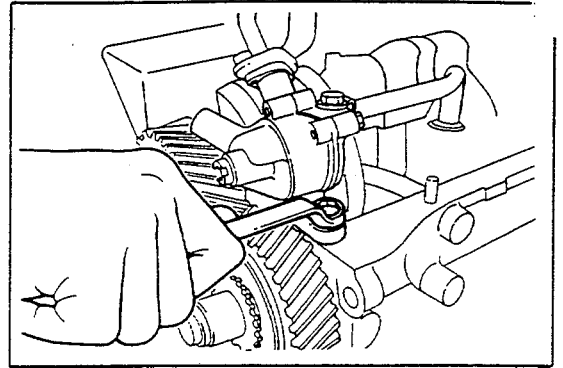

Fig. 5-309

WM-05370

18. Install the oil nozzle. (CB-80 engine only)
Tightening Torque: 3.0 - 3.5 kg-m (22 - 25 ft-lb)

NOTE:

The oil jet can be distorted very easily. Hence, be very careful in handling the oil nozzle assembly so that the assembly may not be damaged.

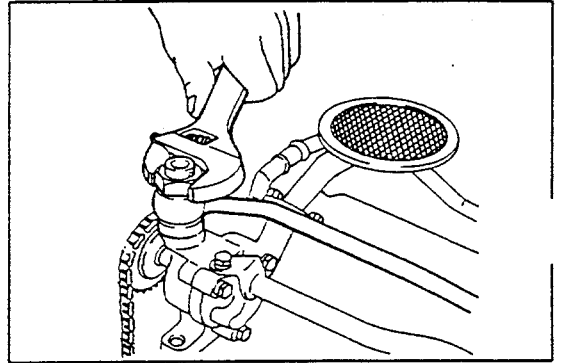

Fig. 5-310

WM-05371

19. Installation of oil pump drive sprocket and oil pump drive chain assembly

- (1) Install the oil pump drive chain to the oil pump sprocket at the balance shaft side.
- (2) With the side having the stamped mark "CB OUTSIDE" facing toward the front side of the engine, install the oil pump drive sprocket to the oil pump with the drive chain installed in place. Then, tighten the attaching nut.

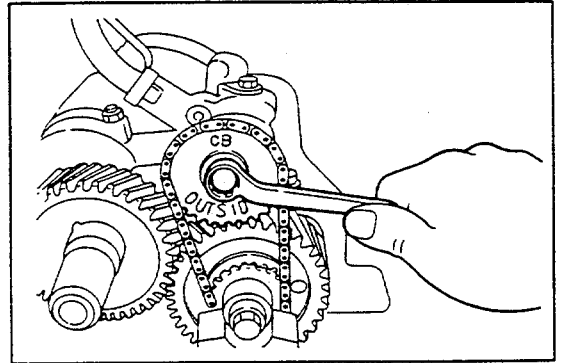

Fig. 5-311

WM-05372

20. Installation of balance shaft gear cover.

- (1) Drive a new oil seal into position, using the following SST.

SST: 09515-87202-000

WM-05

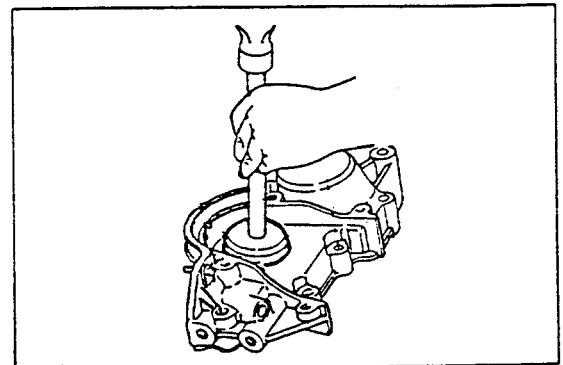

Fig. 5-312

WM-05374

- (2) Install the balance shaft gear cover.
 Tightening Torque: 1.0 - 1.6 kg-m (7.2 - 11.6 ft-lb)

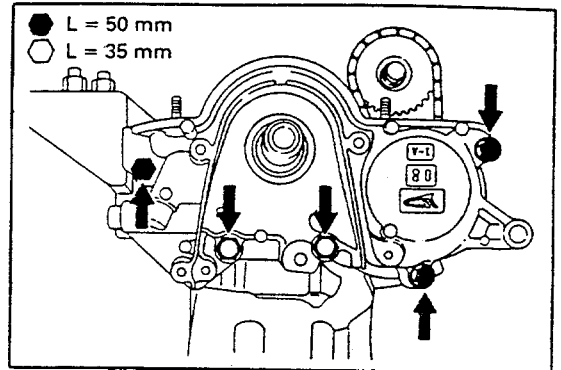

Fig. 5-313

WM-05375

21. Installation of oil pan

- (1) Apply silicon bond to the cylinder block at the points indicated in the right figure.
 Sealer to be Used: Silicon Bond

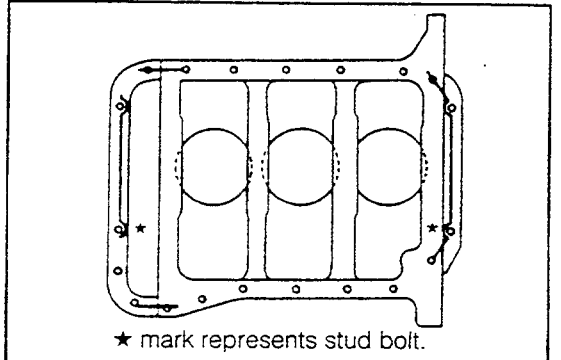

Fig. 5-314

WM-05376

- (2) Apply Silicon Bond to the new oil pan gasket at the points indicated in the right figure.
 Sealer to be Used: Silicon Bond

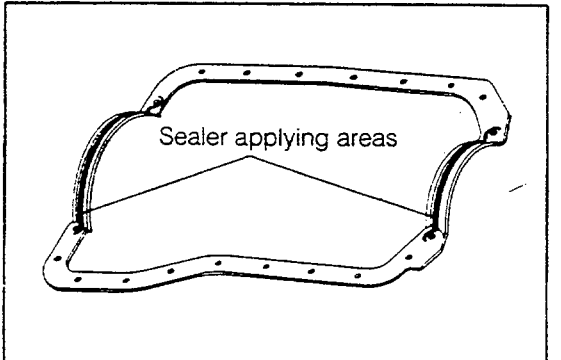

Fig. 5-315

WM-05377

- (3) Install the oil pan gasket applied with silicon bond to the cylinder block, aligning with the stud bolts at the cylinder block.
 (4) Install the oil pan, aligning with the stud bolts at the cylinder block.
 (5) Tighten the oil pan bolts and nuts in the sequence indicated in the right figure.
 Tightening Torque: 0.4 - 0.7 kg-m (2.9 - 5.1 ft-lb)

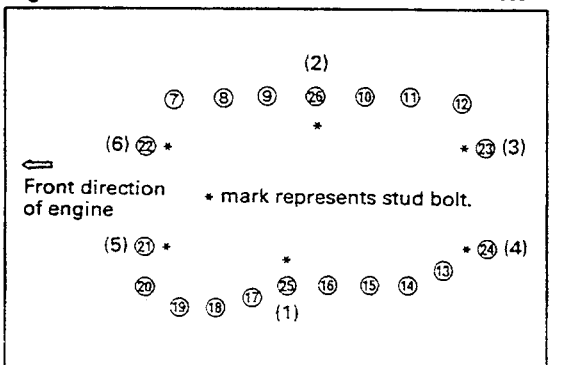

Fig. 5-316

WM-05378

NOTE:

The numerals in () in the right figure denote the sequence of the temporal tightening for the stud bolts.

22. Installation of dust seal (lower)

- (1) Unlock the SST. Turn over the cylinder block.
 (2) Install the dust seal on the balance shaft gear cover.

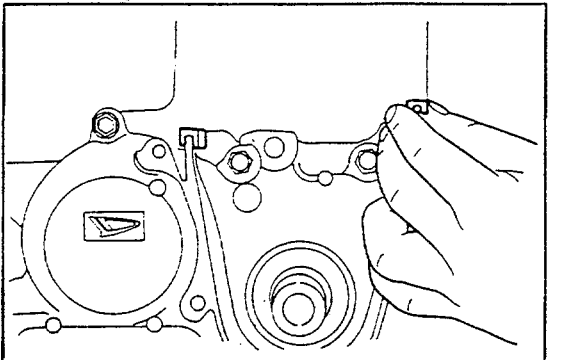

Fig. 5-317

WM-05379

ENGINE MECHANICALS

23. Install the water pump assembly.
24. Install the dust seal (upper).

NOTE:

Be certain that the dust seal is installed in the specified position.

25. Install the water inlet with a new gasket interposed.
26. Installation of water inlet pipe
 - (1) Replace the "O" ring of the water inlet pipe with a new one.
 - (2) Insert the water inlet pipe into the water inlet.
 - (3) Tighten the attaching bolts of the water inlet pipe.

27. Install the oil filter bracket.

28. Install the oil cooler assembly, aligning the mating mark of the oil cooler assembly with the mating mark of the oil filter bracket.

Tightening Torque: 3.0 - 4.0 kg-m (22 - 29 ft-lb)

29. Install the oil cleaner element to the oil cooler.

NOTE:

Prior to the installation, coat the "O" ring of the oil element with a thin film of engine oil. The tightening must be performed by hands. Never use a tool for this purpose.

30. Install the alternator assembly to the cylinder block temporarily.

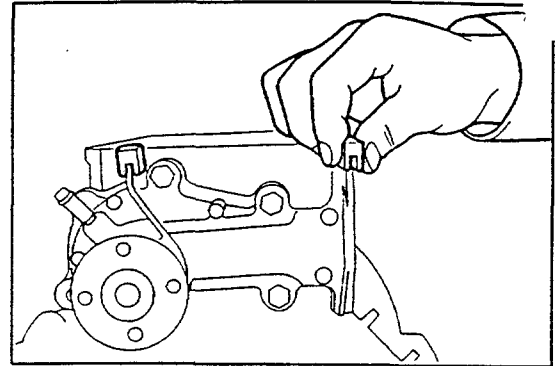

Fig. 5-318

WM-05380

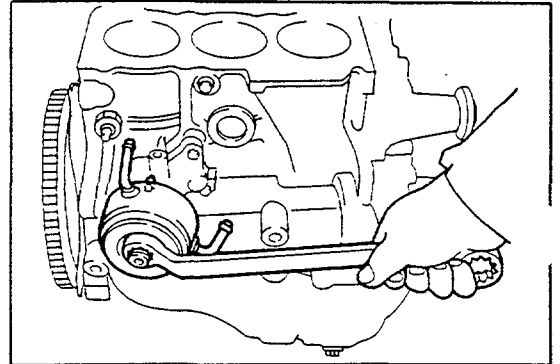

Fig. 5-319

WM-05381

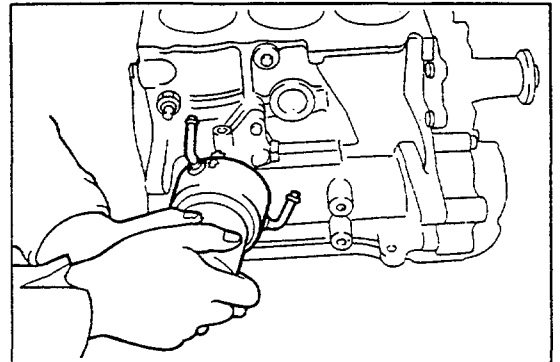

Fig. 5-320

WM-05382

DAIHATSU
TYPE CB
ENGINE

[CB-23, CB-61 & CB-80]

SECTION 6
FUEL SYSTEM

CARBURETOR	6- 2
FUEL LINE [CB-23 Engine]	6- 9
FUEL LINE [CB-61 Engine]	6-11
FUEL PUMP [CB-61 Engine]	6-13
FUEL PUMP [CB-80 Engine]	6-14
FUEL TANK	6-15

WM-06001

FUEL SYSTEM

CARBURETOR

COMPONENTS OF CARBURETOR [CB-23 & CB-61 Engines]

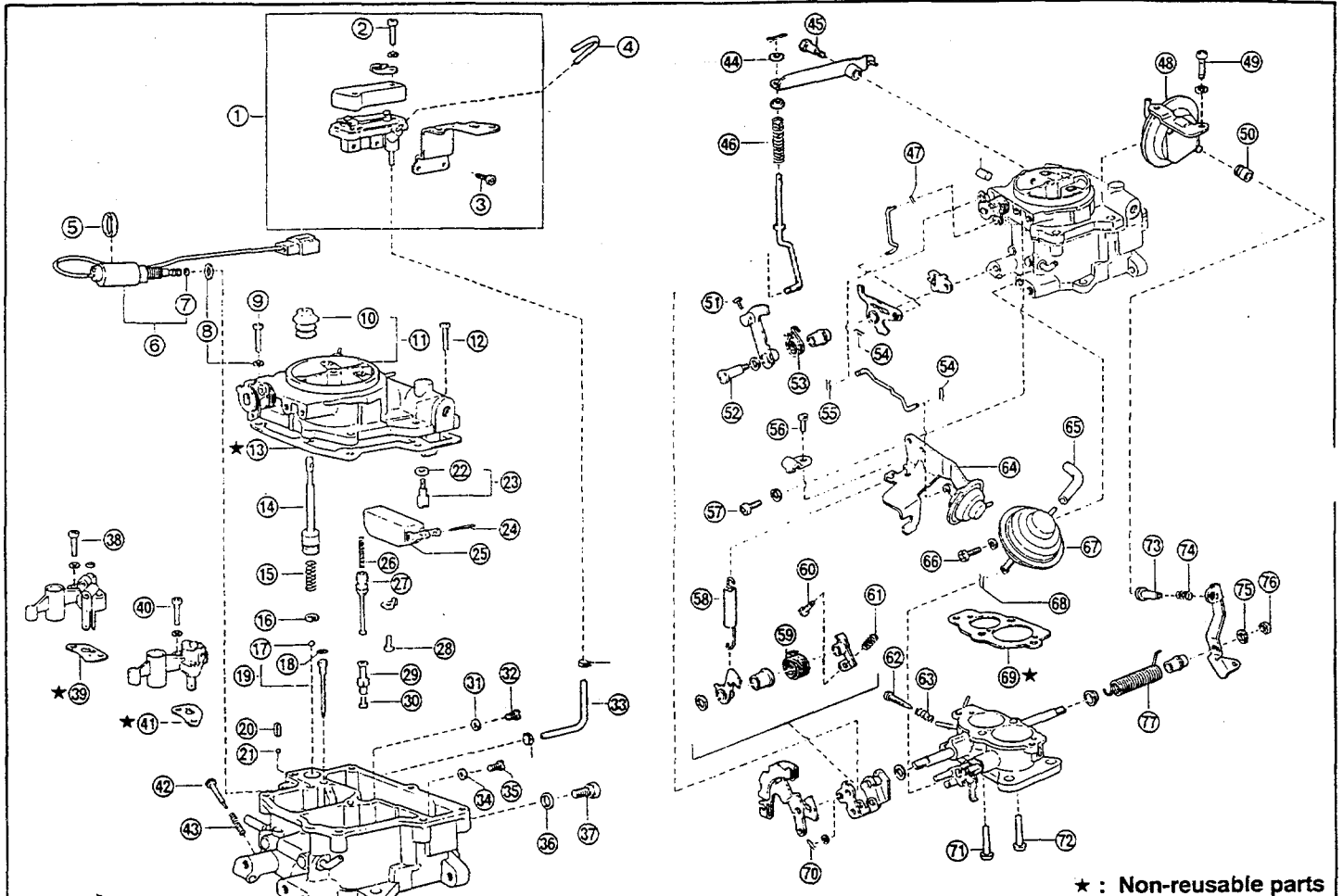

★ : Non-reusable parts

- | | |
|---|---|
| <ul style="list-style-type: none"> ① Thermostatic valve ②, ③, ⑨, ⑫, ⑳, ④① Screw ④, ⑳ Pipe ⑤ Support ⑥ Throttle valve solenoid ⑦, ⑱ "O" ring ⑧ Solenoid valve gasket ⑩ Boot ⑪ Air horn ⑬ Air horn gasket ⑭ Pump plunger ⑮ Pump diaphragm spring ⑯ Check ball retainer ⑰, ㉑ Steel ball ⑲ Slow jet ⑳ Pump discharge weight ㉒ Needle valve seat gasket ㉓ Needle valve ㉔ Float lever pin ㉕ Float ㉖ Power piston spring ㉗ Power piston Power piston stop screw ㉙ Power valve ㉚ Power jet ㉛, ㉜ Main jet gasket ㉝ Primary jet ㉞ Secondary jet ㉟ Main passage plug gasket | <ul style="list-style-type: none"> ㉟ Main passage plug ㊱, ㊲ Venturi gasket ㊳ Throttle adjusting screw ㊴ Throttle adjusting spring ㊵ Plunger inner washer ㊶ Pump arm set screw ㊷ Pump arm spring ㊸, ㊹, ㊺, ㊻, ㊼ Snap ring ㊽ Positioner ㊾, ㊿, ① Screw ② Boot ③ Fast idle cam set screw ④, ⑤, ⑥ Back spring ⑦ Choke wire clamp screw ⑧ Throttle return spring ⑨, ⑩, ⑪ Set screw ⑫ Fast idle cam spring ⑬ Idle adjusting screw ⑭ Idle adjusting spring ⑮ Choke opener ⑯ Vacuum hose ⑰ Diaphragm housing set screw ⑱ Diaphragm ⑲ Body flange gasket ㉒ Adjusting screw ㉓ Adjusting screw spring ㉔ Lock washer ㉕ Throttle lever set nut |
|---|---|

Fig. 6-1

WM-06002

...RBURETOR SCHEMATIC DIAGRAM [CB-23 Engine]

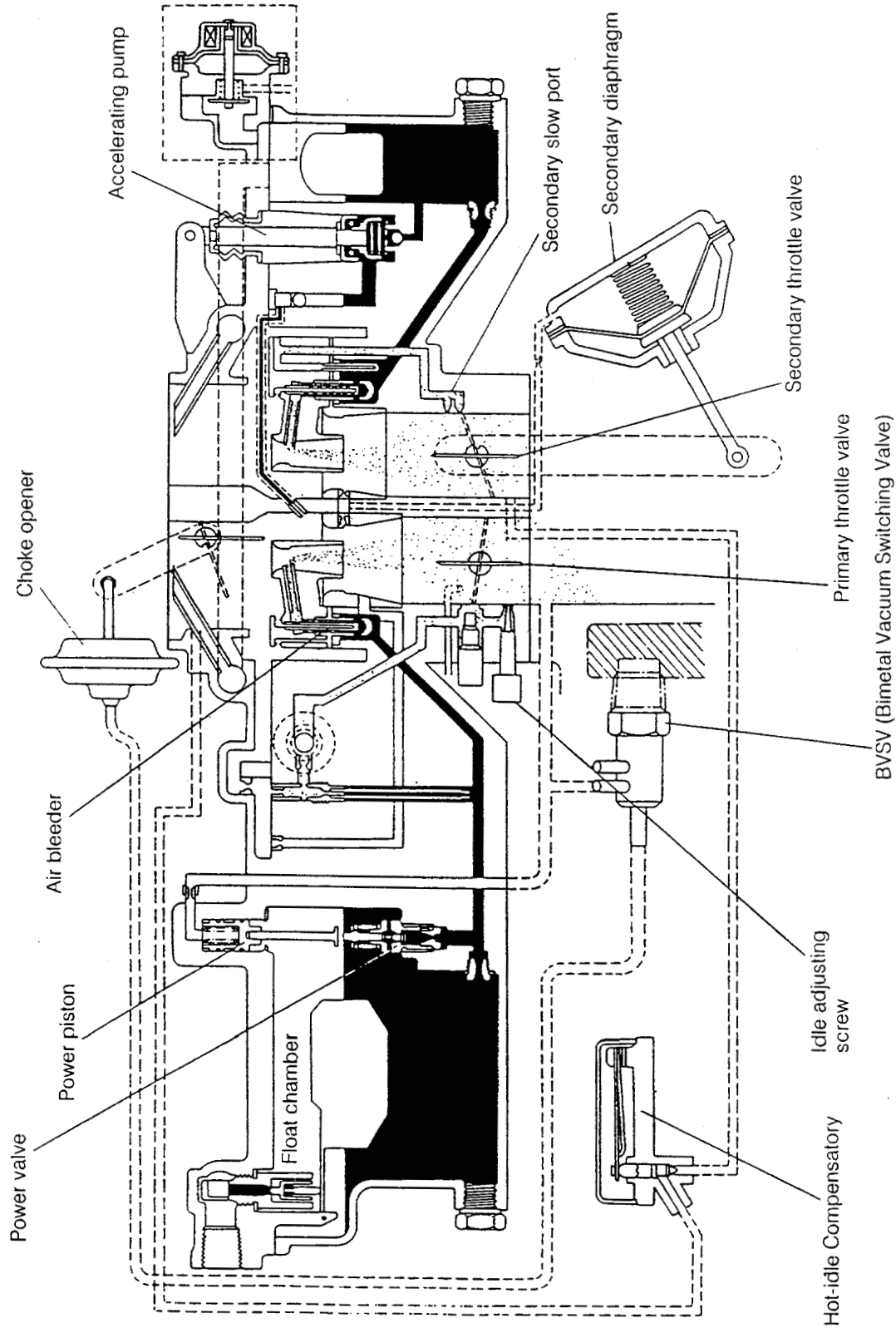

Fig. 6-2

WM-06003

FUEL SYSTEM

CARBURETOR SCHEMATIC DIAGRAM [CB-61 Engine]

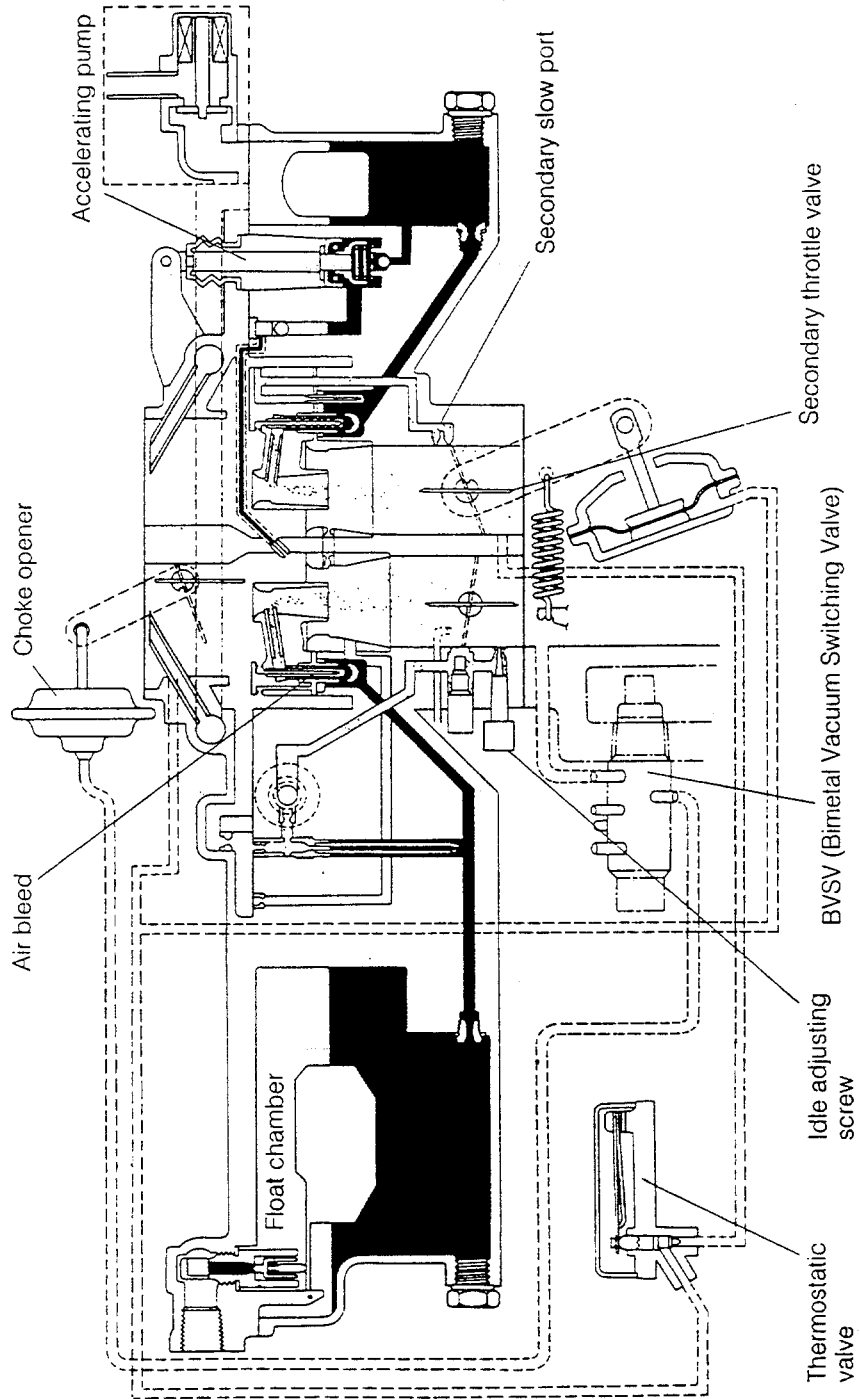

Fig. 6-3

WM-06004

SPECTION

NOTE:

- (1) Before inspecting the parts, wash them thoroughly in gasoline.
Using compressed air, blow all dirt and other foreign matter from the jets and similar parts, and from the fuel passages and apertures in the body.
- (2) Never clean the jets or orifices with wire or drill. This could enlarge the openings and result in excessive fuel consumption.

Body

- (1) Check the body for cracks. Check each hole for distric-tion.
- (2) Check the small venturi for restriction.
- (3) Check the large venturi for looseness or excessive wear.

Air Horn

- (1) Check the air horn for distortion or damage.
- (2) Check each passage of the air horn for restriction.
- (3) Check the choke valve for proper function.

Float

Check to see if any gasoline ingress is present. Also, check the lever pine hole for wear.

Needle Valve and Seat

Check for the contact surfaces.

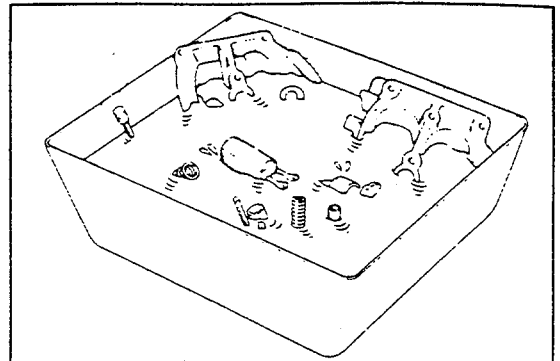

Fig. 6-4

WM-06005

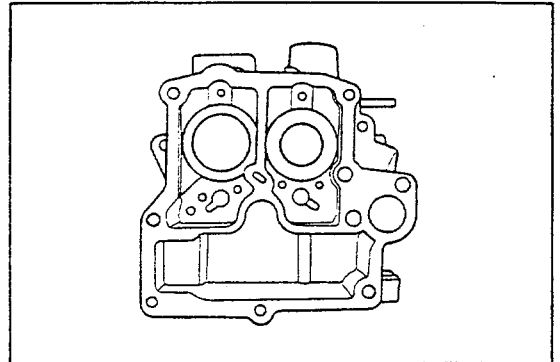

Fig. 6-5

WM-06006

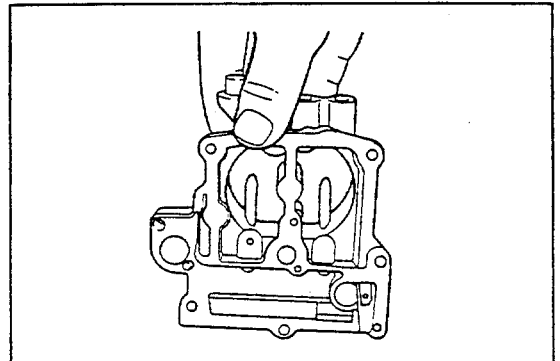

Fig. 6-6

WM-06007

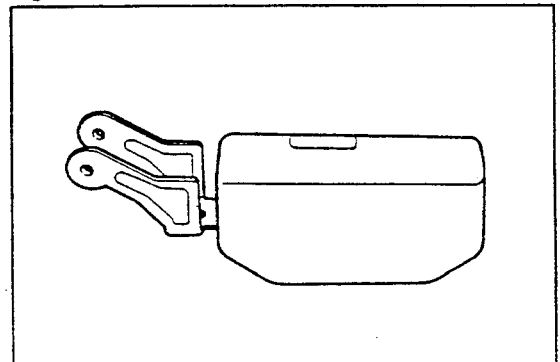

Fig. 6-7

WM-06008

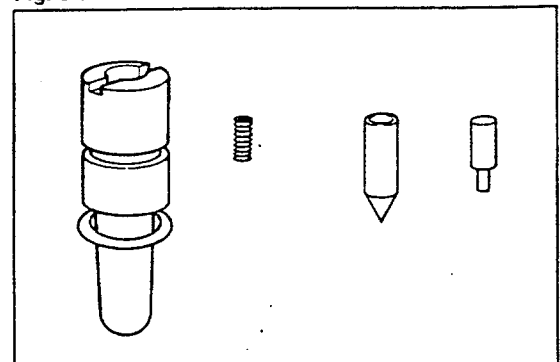

Fig. 6-8

WM-06009

FUEL SYSTEM

Jets

Check the holes, threads and screw driver grooves for signs of damage.

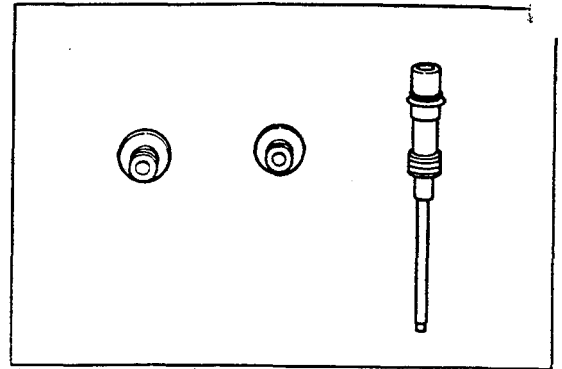

Fig. 6-9

WM-06010

Idle Adjusting Screw

Check the tapered section or threads for damage.

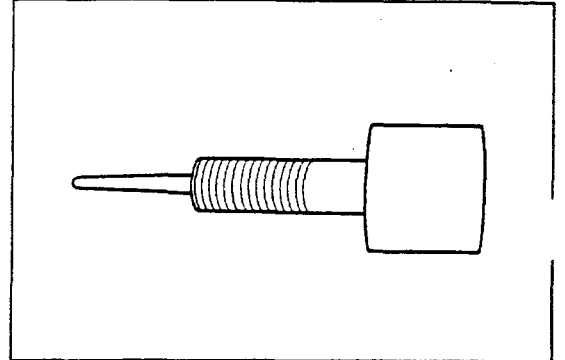

Fig. 6-10

WM-06011

Power Valve

Ensure that no leak is seen when your breath is blown through lower part.
Check for smooth operation.

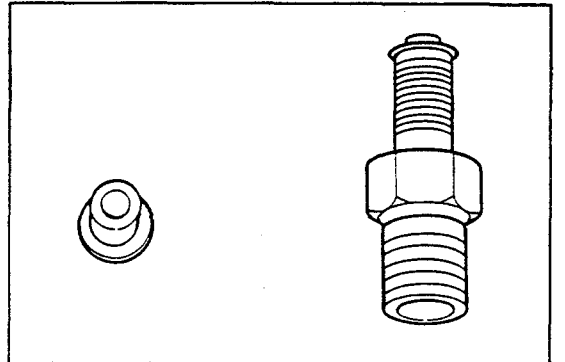

Fig. 6-11

WM-06012

Solenoid Valve

Check the solenoid valve connecting wire to the battery positive \oplus terminal for proper operation by grounding the body. The needle valve should be pulled in.

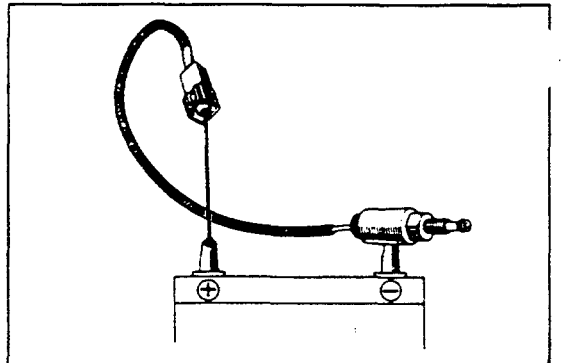

Fig. 6-12

WM-06013

Diaphragm

Connect a hose to the diaphragm and suck the hose. The diaphragm should move. If not, replace the diaphragm.

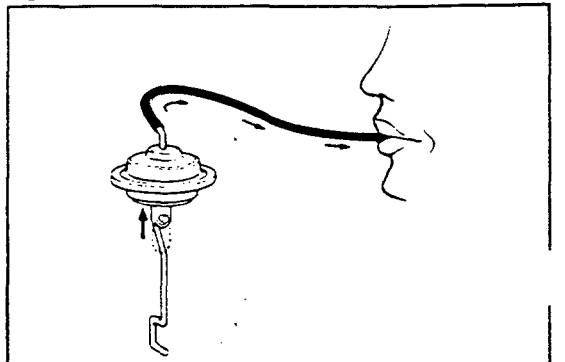

Fig. 6-13

WM-06014

Thermostatic Valve

Lightly blow into the thermostatic valve through the (A) side. If there is no air continuity, it indicates a satisfactory operation.

UNIT CHECK

NOTE:

When the carburetor has been disassembled, be certain to install new seals and gaskets during the reassembly.

1. Float Level Check and Adjustment

(1) Detach the clip that has been attached on the needle valve. Reinstall the needle valve. Carry out the float level check and adjustment.

(2) Float ascent position check and adjustment

① Invert the air horn and allow the float to hang down by its own weight.

Measure the minimum gap between the projected section of the float and the air horn.

Specified Gap: 8.0 mm (0.315 inch)

② If the gap does not conform to the specification, bend the section A in order that the specified gap may be obtained.

When the float is at the ascent position, the minimum gap between the projected section of the float and the air horn should be measured as shown in the right figure.

When the float's right end is higher than the float's left end, the left end of the projected section will be measuring point. Conversely, when the float's right end is lower than the float's left end, the right end of the projected section will be measuring point. Adjustment is made by bending the section A.

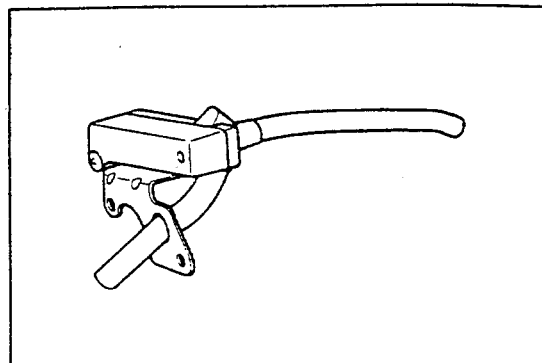

Fig. 6-14

WM-06015

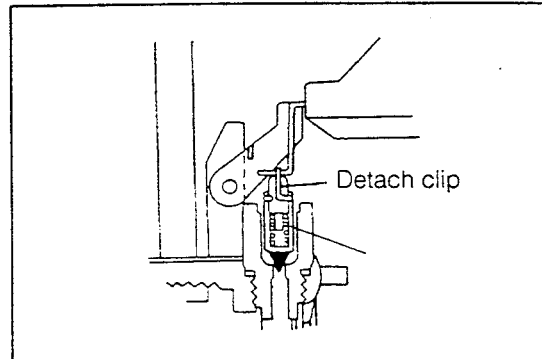

Fig. 6-15

WM-06016

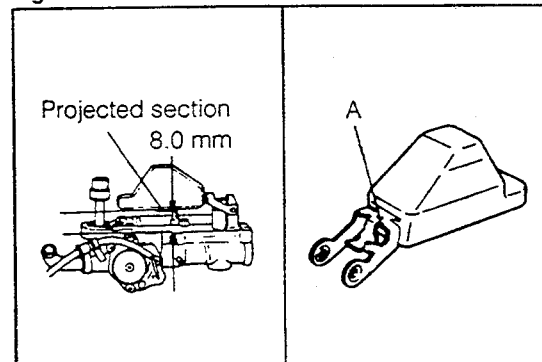

Fig. 6-16

WM-06017

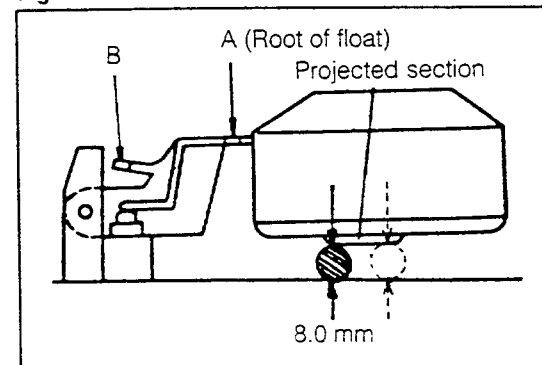

Fig. 6-17

WM-06018

FUEL SYSTEM

(3) Float descent position check and adjustment

- ① Raise the float and measure the lip clearance.

Specified Clearance: 1.6 mm (0.063 inch)

- ② If the clearance does not conform to the specification, bend the section B in order that the specified clearance may be obtained.

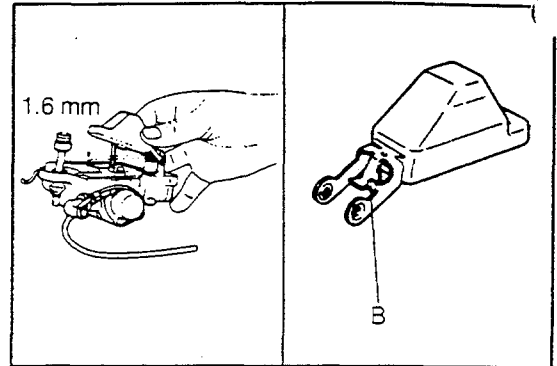

Fig. 6-18

WM-06019

2. Secondary diaphragm check (CB-61)

Disconnect the vacuum hose at the diaphragm side. Connect the turbo charger pressure gauge and apply a positive pressure of 0.2 kg/cm² (2.8 psi). If the link moves, it indicates that the secondary diaphragm is functioning normally.

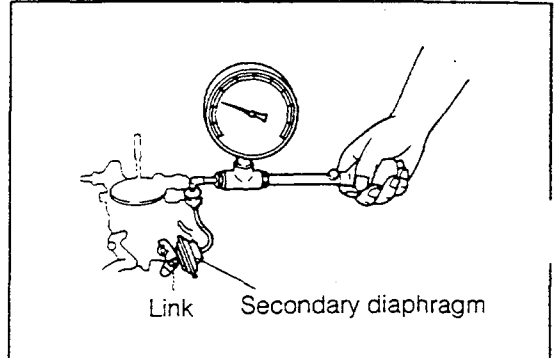

Fig. 6-19

WM-06020

3. Checking of jet operation

- (1) With the white-colored (or orange-colored) port plugged, connect a MityVac to the orange-colored (or white-colored) port. Apply a negative pressure of 500 mmHg. If the pointer is steady, it indicates a normal operation.

- (2) Replace the white-colored (or orange-colored) port. Measure the time required for the negative pressure to drop from 400 mmHg to 200 mmHg.

Time Required for Dropping: About one second

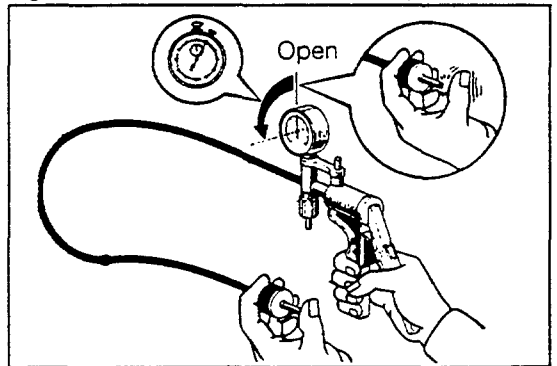
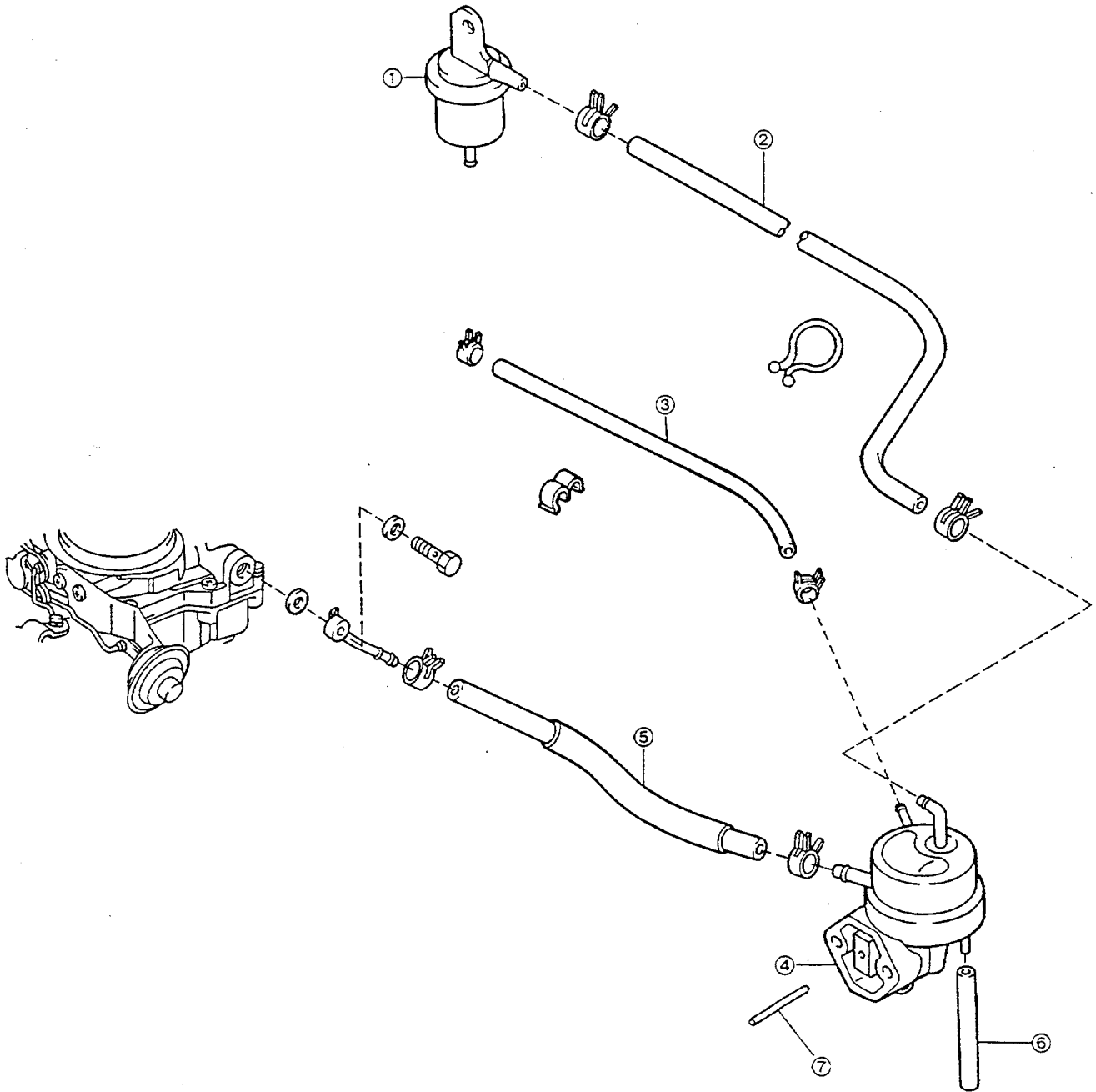

Fig. 6-20

WM-06021

FUEL LINE
 COMPONENTS OF FUEL LINE [CB-23 Engine]



- ① Fuel filter
- ② Fuel hose (Filter to Pump)
- ③ Fuel hose (For return)
- ④ Fuel pump
- ⑤ Fuel hose (Pump to carburetor)
- ⑥ Hose
- ⑦ Push rod

Fig. 6-21

WM-06034

FUEL SYSTEM

INSPECTION

1. Check the fuel pump for proper check valve operation.
(1) Ensure that air continuity exists when blown from the section ①.

NOTE:

Never attempt to suck the section.

2. Ensure that no air continuity exists when blown from the section ②.

NOTE:

Never attempt to suck the section.

3. Measure the overall length of the push rod.

Length:

STD 31.6 - 31.8 mm (1.244 - 1.252 inches)

Limit 31.1 mm (1.224 inches)

4. Check the fuel pump drive cam for wear.

- (1) Insert a good push rod into the distributor housing.
- (2) Turn the crankshaft two turns (i.e. turn the camshaft one turn). Measure the maximum amount as well as the minimum amount of protrusion between the distributor housing's edge and the tip-end the push rod.

- (3) If the amount of protrusion is less than limit, replace the fuel pump drive cam.

Maximum amount of protrusion:

STD 10.5 - 11.5 mm (0.4134 - 0.4528 inch)

Limit 10.0 mm (0.3937 inch)

Minimum amount of protrusion:

STD 8.5 - 9.5 mm (0.3346 - 0.3740 inch)

Limit 8.0 mm (0.3150 inch)

Stroke: 2.0 mm (0.0787 inch)

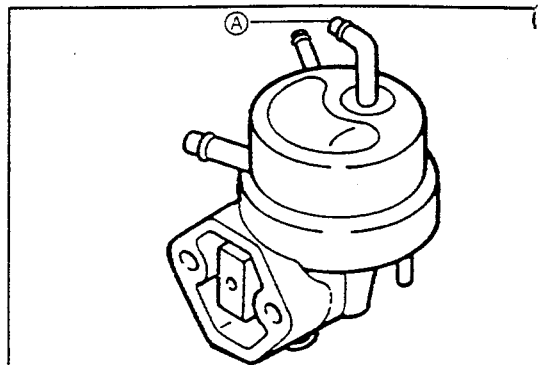

Fig. 6-22

WM-06035

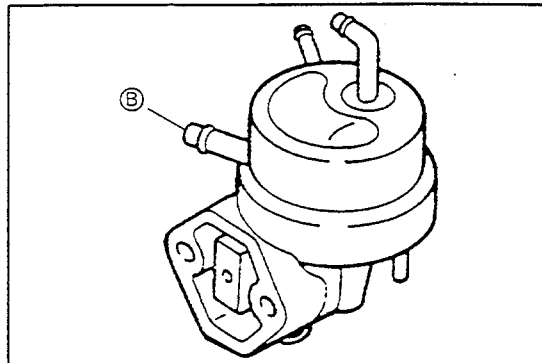

Fig. 6-23

WM-06036

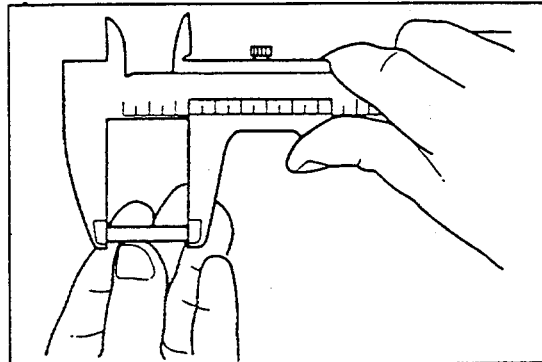

Fig. 6-24

WM-06037

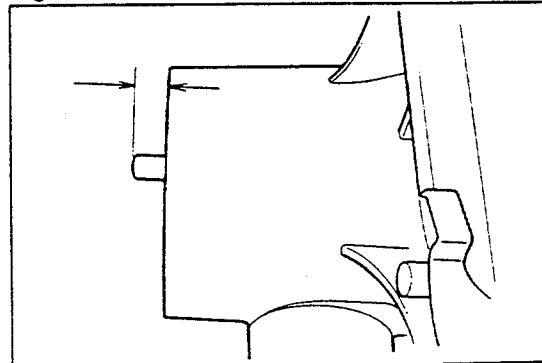

Fig. 6-25

WM-06037A

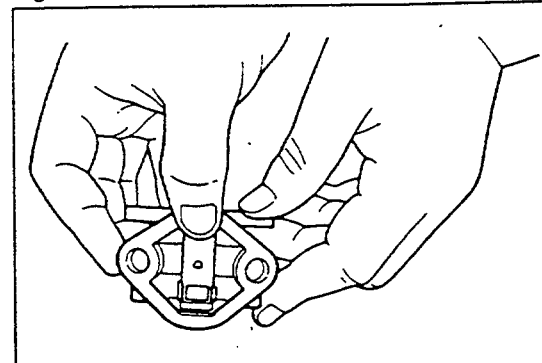
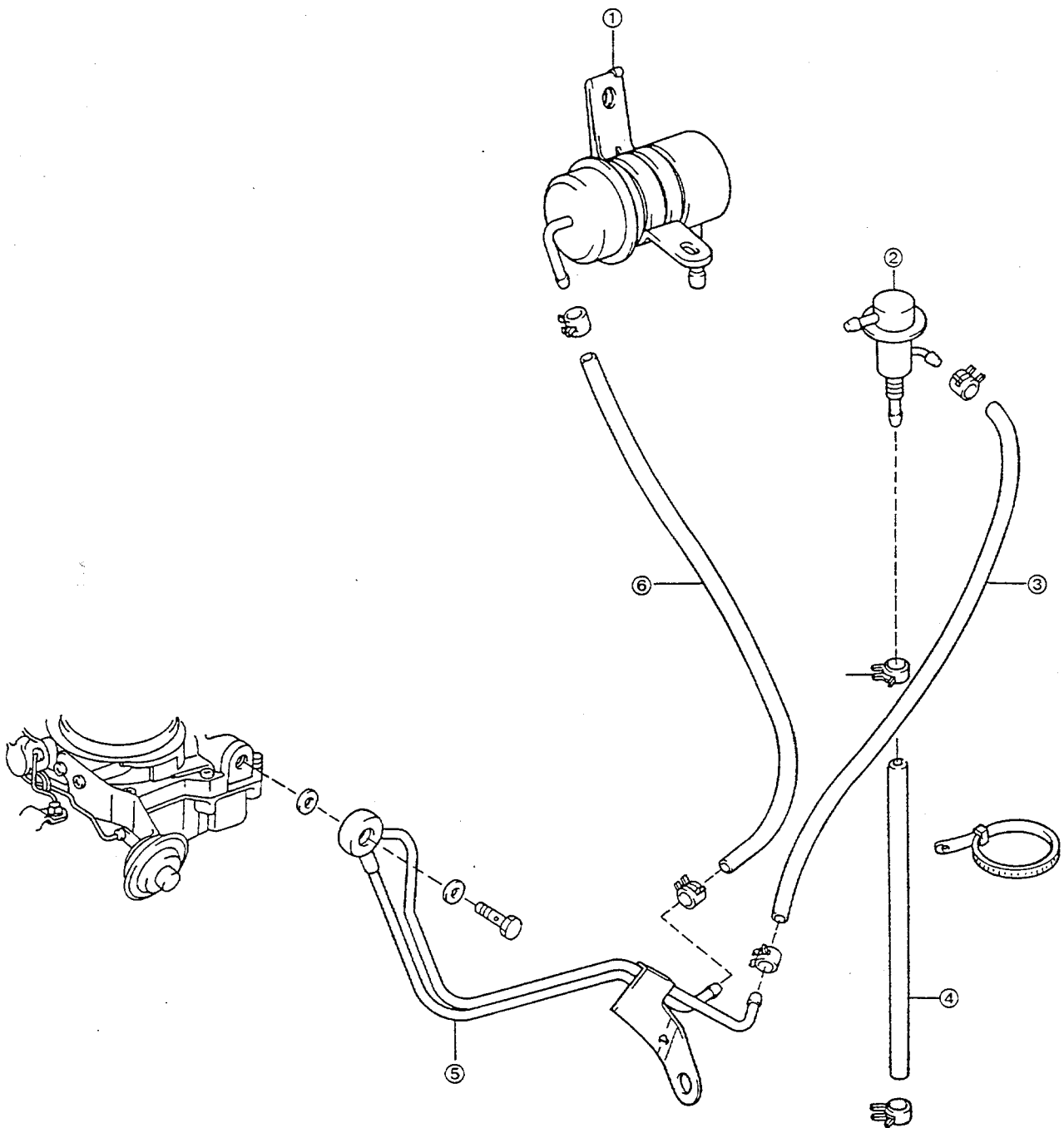

Fig. 6-26

WM-06037B

COMPONENTS OF FUEL LINE [CB-61 Engine]



- ① Fuel filter
- ② Fuel pressure control valve
- ③ Fuel hose (Value to carburetor)
- ④ Fuel hose (Value to tank)
- ⑤ Fuel pipe No.1
- ⑥ Fuel hose (Carburetor to filter)

Fig. 6-27

WM-06038

FUEL SYSTEM

IN-VEHICLE INSPECTION [CB-61 Engine]

1. If any work related to the fuel system has been performed, it is mandatory to make sure that the fuel system exhibits no leakage under a condition where the fuel pressure is applied.
2. Remove the fuel tank cap so that the tank internal pressure may be released.
3. Disconnect the fuel hose connecting the fuel filter to the carburetor and the fuel hose connecting the carburetor to the pressure control valve. These fuel hoses should be disconnected at the carburetor side.

NOTE:

When the fuel hoses are disconnected, make certain that the engine is already cool. Also, be sure to plug the fuel hoses, using cloth or the like.

4. Connect a fuel pressure gauge.
Fuel pressure gauge:
SST: 09268-87701-000
Fuel pressure gauge attachment:
SST: 09283-87701-000
5. Disconnect the connector from the magnetic switch of the starter. (This step is taken to prevent the starter rotation.)
6. Turn the engine switch to the "ST" position.
7. Measure the fuel pressure under this setting.
Specified Fuel Pressure:
0.25 to 0.35 kg/cm² (3.6 to 5.0 psi)
8. Disconnect the vacuum hose between the pressure control valve and the 4-way joint. Then, connect the turbocharger pressure gauge.
9. Apply a positive pressure of 0.5 kg/cm² (7.1 psi) and measure the fuel pressure under this setting.
Specified Fuel Pressure:
0.75 to 0.85 kg/cm² (10.7 to 12.1 psi)

EMERGENCY FUEL STOP SYSTEM

IN-VEHICLE INSPECTION [CB-61 Engine]

1. Start the engine.
2. Disconnect the noise filter connector for the tachometer. If the fuel pump stops its operation, it indicates that the emergency fuel stop system is functioning normally.

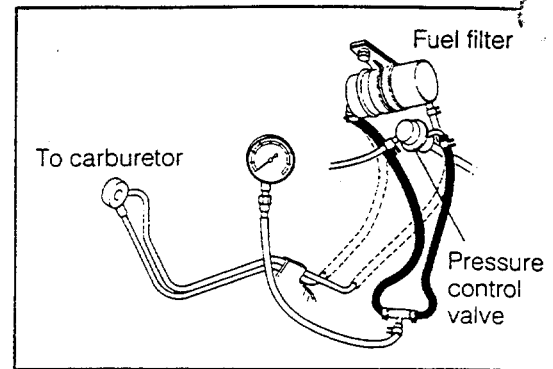

Fig. 6-28

WM-06039

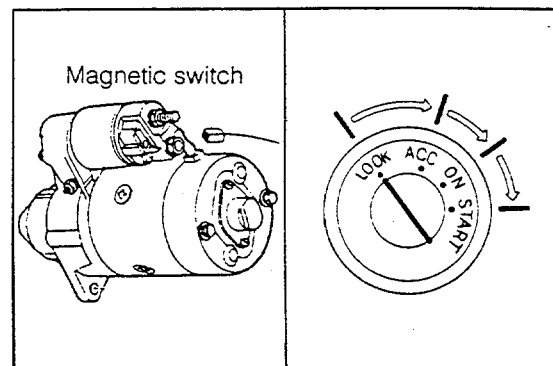

Fig. 6-29

WM-06040

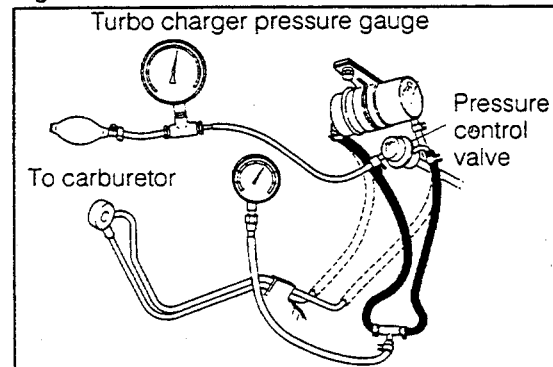

Fig. 6-30

WM-06041

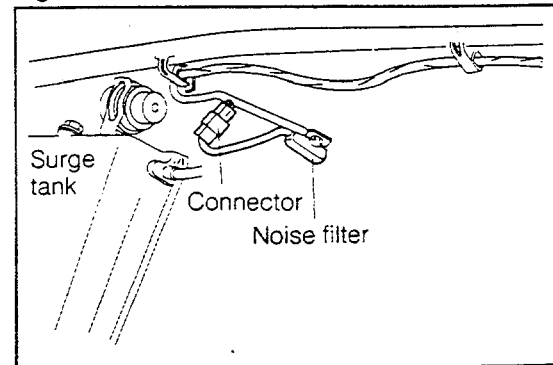
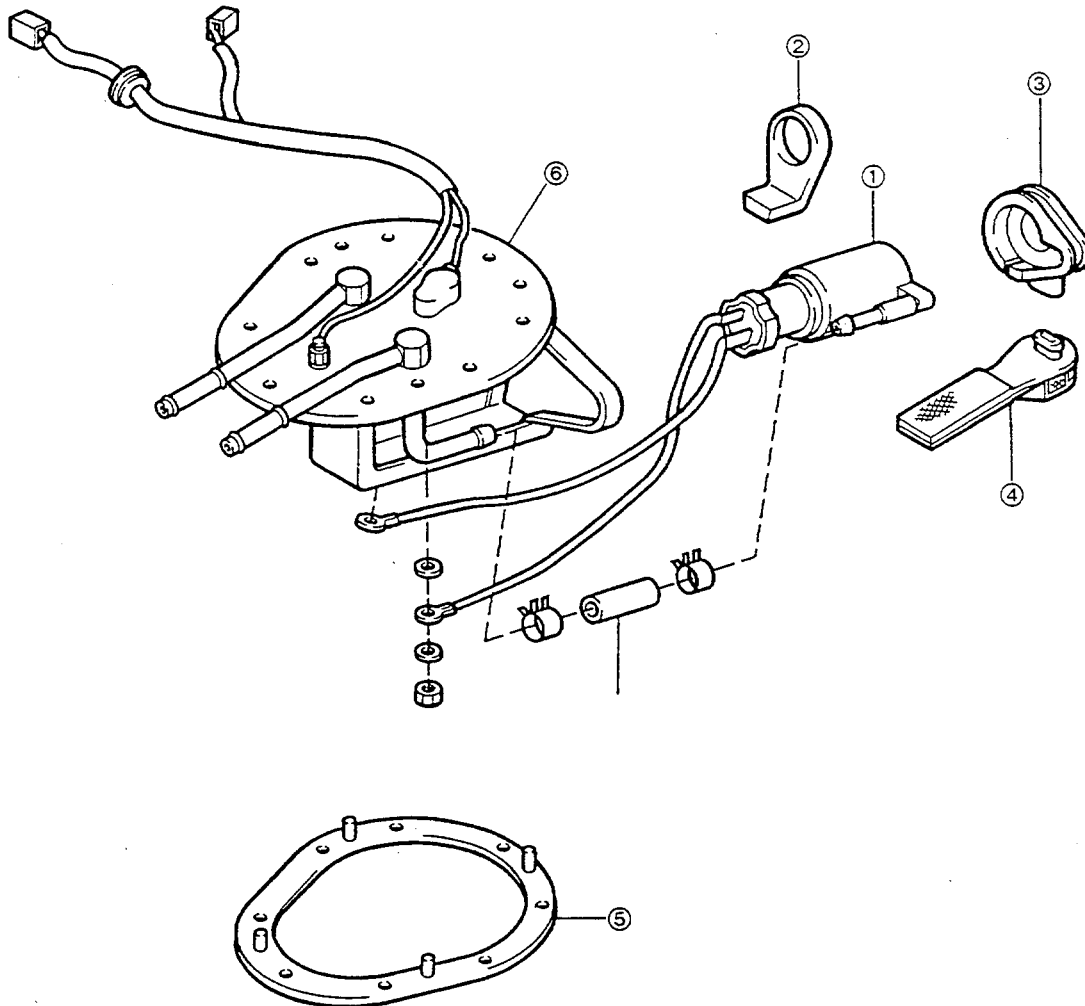

Fig. 6-31

WM-06042

JEL PUMP

COMPONENTS OF FUEL LINE [CB-61 Engine]



- ① Fuel pump Ay
- ② Cushion rubber
- ③ Fuel pump cover
- ④ Fuel pump filter
- ⑤ Gasket
- ⑥ Bracket S/A

Fig. 6-32

WM-06046

FUEL SYSTEM

COMPONENTS OF FUEL LINE [CB-80 Engine]

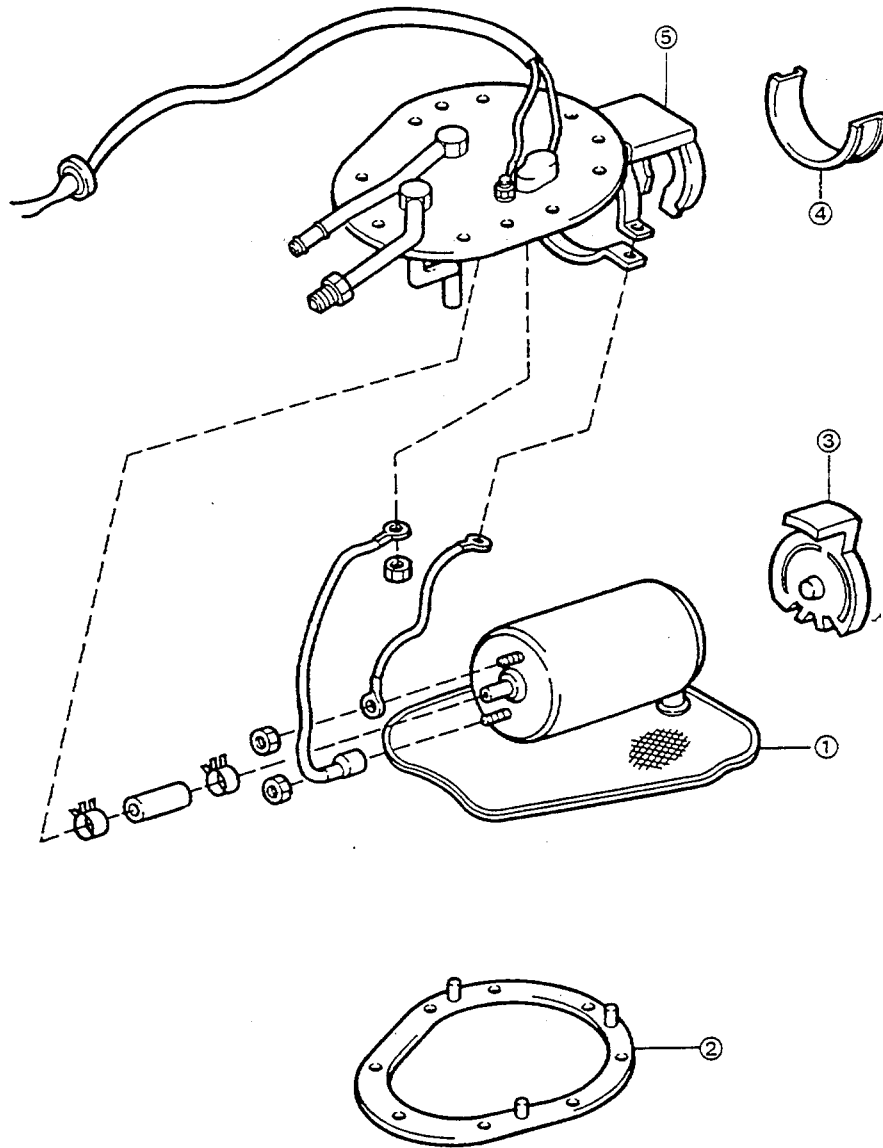

- ① Fuel pump Ay
- ② Fuel pump gasket
- ③ Fuel pump cover
- ④ Cushion rubber
- ⑤ Bracket S/A

Fig. 6-33

WM-06047

JEL TANK

REMOVAL

1. Jack up the vehicle and support it with safety stands.
2. Drain the fuel from the fuel tank by removing the drain plug. (After the fuel tank has been drained, install the drain plug in the original position.)

3. Disconnection of connectors of fuel sender gauge and fuel pump
 - (1) Remove the rear seat.
 - (2) Detach the rear quarter trim at the right side. (3-door model)
 - (3) Remove the rear scuff plate at the right/rear side. (5-door model)
 - (4) Disconnect the connector. Take out the connector together with the grommet.

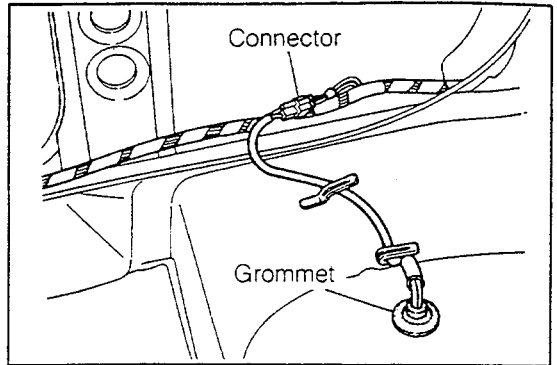

Fig. 6-34

WM-06048

4. Removal of fuel tank subinlet hose and breather hose

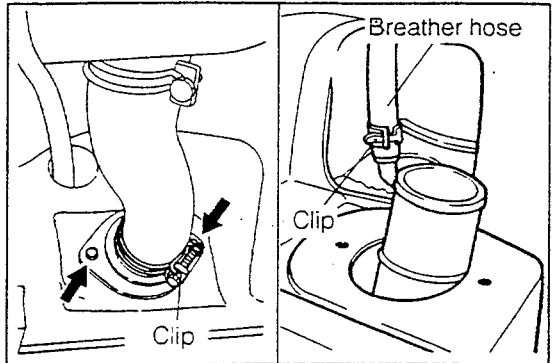

Fig. 6-35

WM-06049

3-door model

- (1) Detach the clamp. Disconnect the fuel tank subinlet hose.
- (2) Detach the clamp. Disconnect the breather hose.

5-door model

- (1) Detach the clamp. Disconnect the fuel tank subinlet hose.
- (2) Remove the clip and hose at both sides of the breather hose.
- (3) Remove the attaching bolt of the breather pipe. Remove the breather pipe.

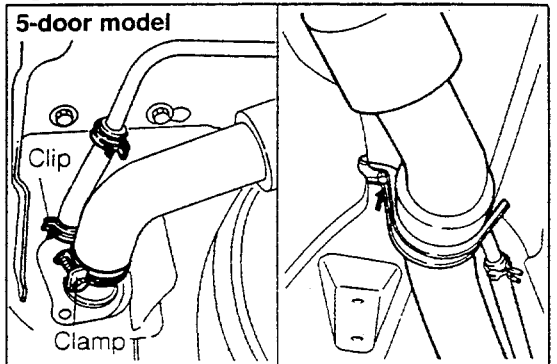

Fig. 6-36

WM-06050

5. Removal of fuel hoses

- (1) Disconnect the main fuel hose.
- (2) Disconnect the return fuel hose.
- (3) Disconnect the fuel hose for emission control use.

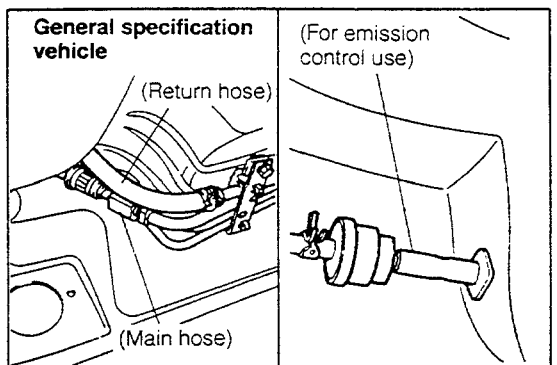

Fig. 6-37

WM-06051

FUEL SYSTEM

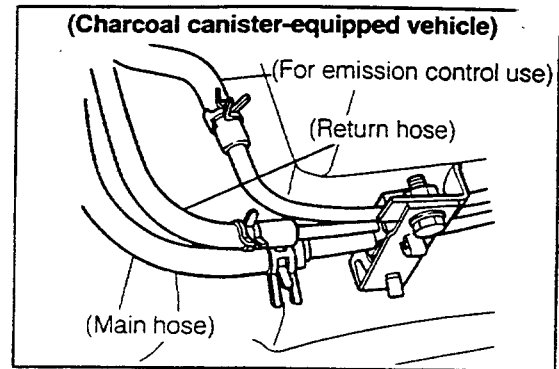

Fig. 6-38

WM-06052

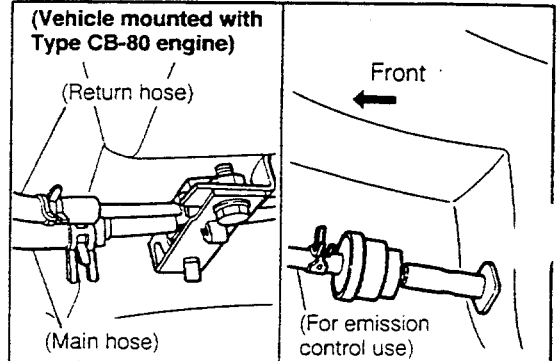

Fig. 6-39

WM-06053

6. Removal of fuel tank assembly
 - (1) Support the fuel tank with a jack.
 - (2) Remove the four attaching bolts of the fuel tank.
 - (3) Take out the fuel tank assembly from the vehicle.

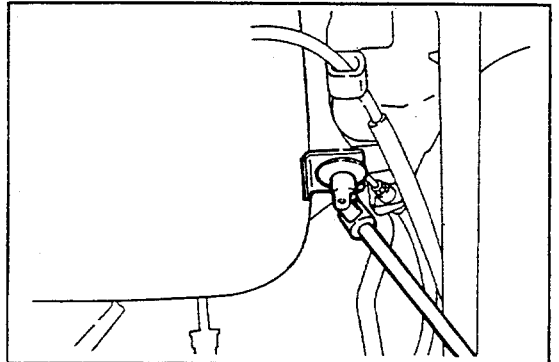

Fig. 6-40

WM-06054

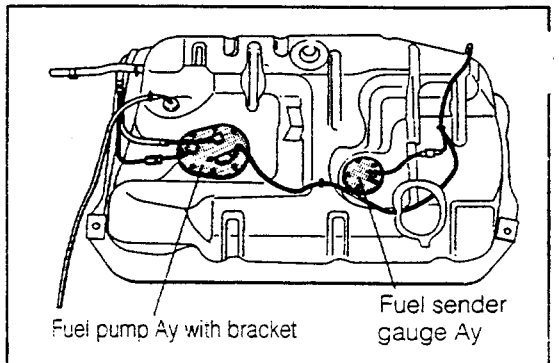

Fig. 6-41

WM-06055

7. Remove the fuel hose and pipe.
8. Remove the coupler and five screws. Remove the fuel sender gauge assembly.
9. Remove the fuel pump assembly with bracket by removing the eight screws.

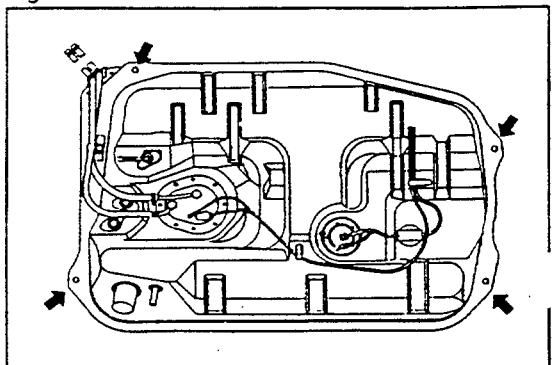

Fig. 6-42

WM-06056

INSPECTION

1. Check to see if the fuel pump filter exhibits restriction.
2. Apply the battery voltage to the fuel pump. Check to see if the fuel pump functions smoothly.

[Reference]

Fuel pump specifications

Item		CB-61	CB-80
Delivery output	l/h	Not less than 60	Not less than 80

WM-06057

INSTALLATION

1. Install the fuel pump assembly with bracket and the fuel sender gauge assembly.
2. Install the fuel hose and pipe.
3. Install the fuel tank assembly with the four bolts.

NOTE:

Prior to the installation of the fuel tank assembly, be sure to route the fuel gauge-related harness through the inside.

4. Installation of fuel hoses
 - (1) Connect the main fuel hose.
 - (2) Connect the return fuel hose.
 - (3) Connect the fuel hose for emission control use.

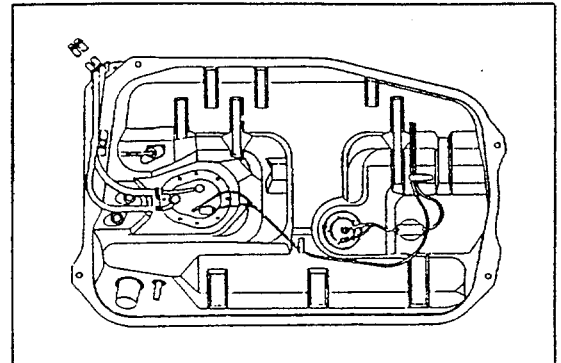

Fig. 6-43

WM-06058

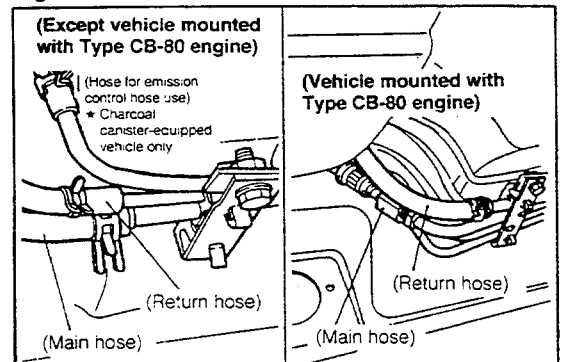

Fig. 6-44

WM-06059

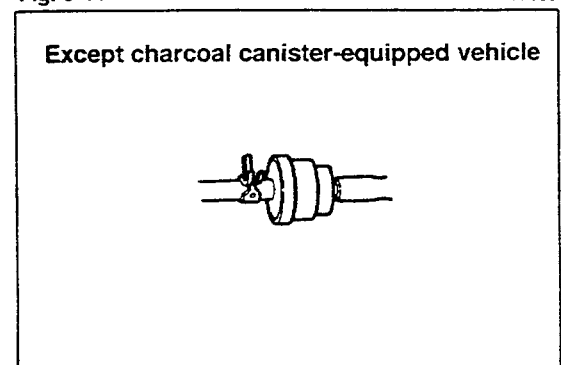

Fig. 6-45

WM-06060

FUEL SYSTEM

5. Install the fuel tank subinlet hose and breather hose.

3-door model

- (1) Connect the breather hose. Secure it with the clip.
- (2) Connect the fuel tank subinlet hose. Secure it with the clamp.

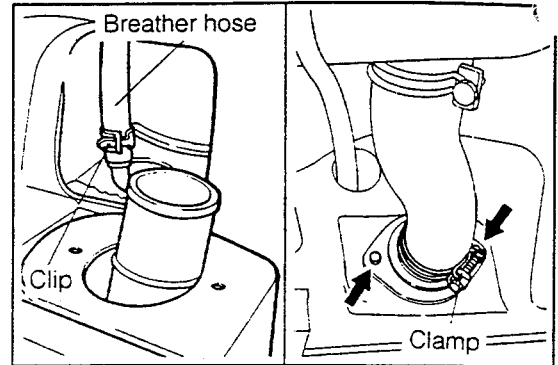

Fig. 6-46

WM-06061

5-door model

- (1) Connect the fuel tank subinlet hose. Secure it with the clamp.
- (2) Connect the hoses to both ends of the breather pipe. Secure them with the clips.
- (3) Install the breather pipe with one bolt.

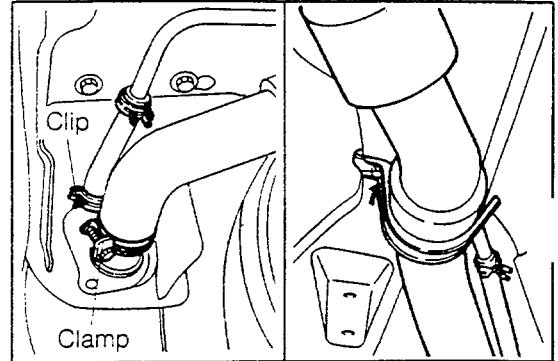

Fig. 6-47

WM-06062

6. Installation of fuel sender gauge and fuel pump connectors

- (1) Connect the connectors and install the grommet.
- (2) Attach the rear quarter trim at the right side. (3-door model)
- (3) Attach the scuff plate at the right/rear side. (5-door model)
- (4) Install the rear seat.

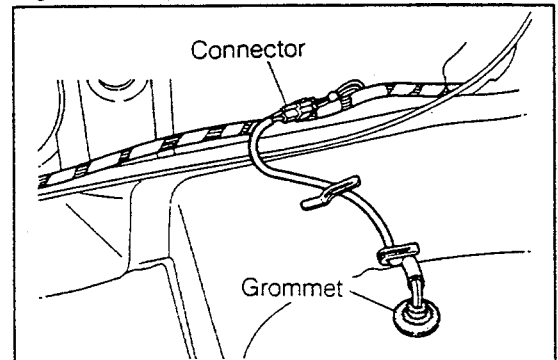

Fig. 6-48

WM-06063

DAIHATSU
TYPE CB
ENGINE

[CB-23, CB-61 & CB-80]

SECTION 7
LUBRICATION SYSTEM

OIL PUMP	7-2
COMPONENTS OF OIL PUMP	7-2
INSPECTION	7-3
ASSEMBLY	7-4
OIL COOLER	7-7
COMPONENTS OF OIL COOLER [CB-61]	7-7
COMPONENTS OF OIL COOLER [CB-80]	7-8
INSTALLATION	7-9
INSPECTION	7-9

WM-07001

LUBRICATION SYSTEM

OIL PUMP

COMPONENTS OF OIL PUMP

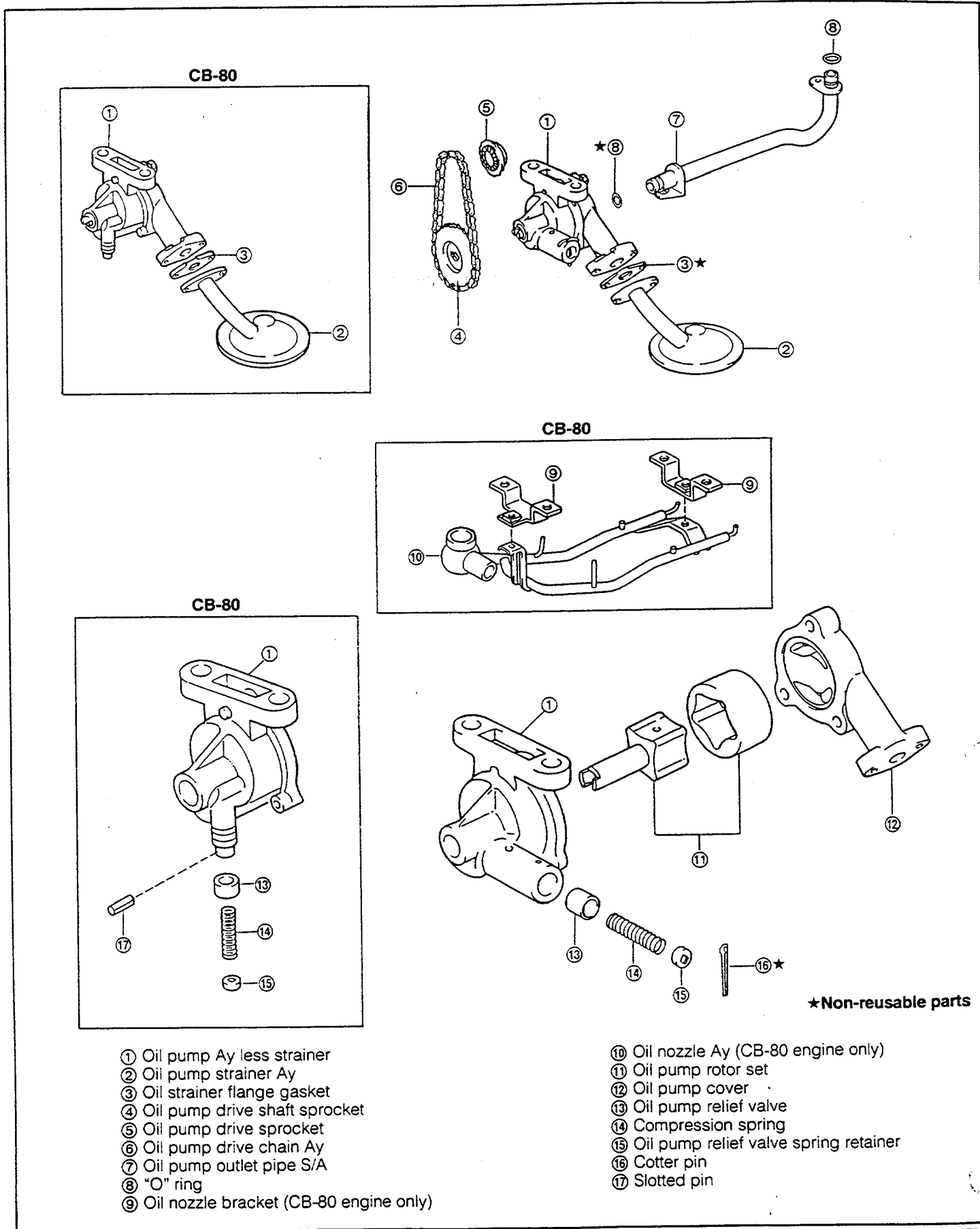

Fig. 7-1

WM-07002

INSPECTION

1. Oil pump drive shaft sprocket Check for cracks and damage.

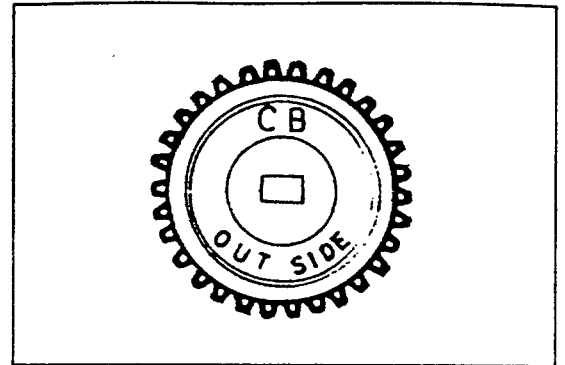

Fig. 7-2

WM-07004

2. Oil pump chain Check for damage.

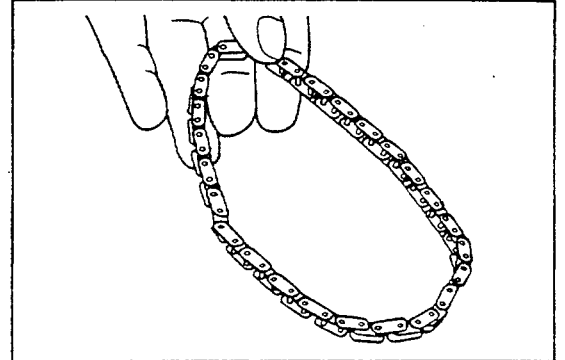

Fig. 7-3

WM-07005

3. Measurement of shaft clearance

Specified Clearance: 0.045 - 0.085 mm
(0.0018 - 0.0033 inch)
Limit: 0.10 mm (0.0039 inch)

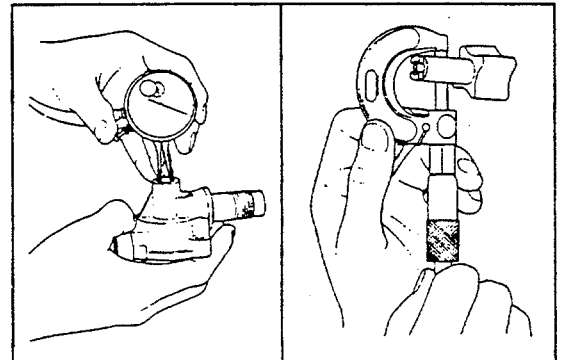

Fig. 7-4

WM-07006

4. Measurement of tip clearance

Specified Clearance: 0.15 mm (0.0059 inch) or less
Limit: 0.25 mm (0.0098 inch)

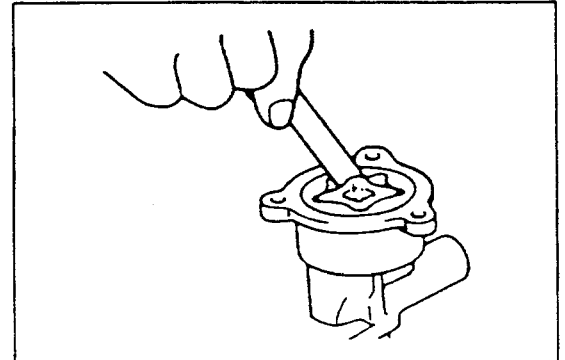

Fig. 7-5

WM-07007

5. Side clearance

Specified Clearance: 0.03 - 0.09 mm
(0.0012 - 0.0035 inch)
Limit: 0.20 mm (0.0079 inch)

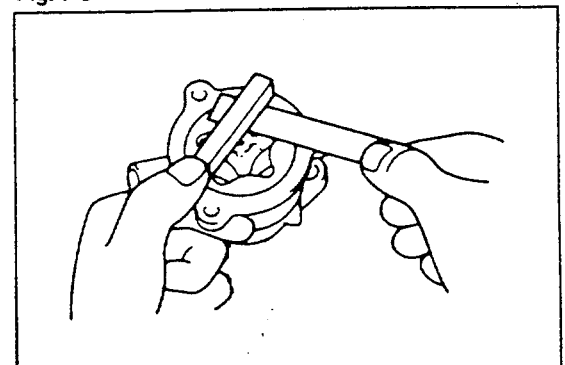

Fig. 7-6

WM-07008

LUBRICATION SYSTEM

6. Body clearance
Specified Clearance: 0.10 - 0.16 mm
(0.0039 - 0.0063 inch)
Limit: 0.30 mm (0.0118 inch)

7. Relief valve
Check the oil passage and sliding surface for damage.

ASSEMBLY

1. Assemble the relief valve in the numerical order shown in the figure.

2. Oil pump rotor set
Assemble the rotor in such a way that the punched marks point toward the same direction (facing toward you).
NOTE:
Coat each sliding part with engine oil.

3. Oil pump cover and body
Tightening Torque: 0.4 - 0.7 kg-m (2.9 - 5.1 ft-lb)

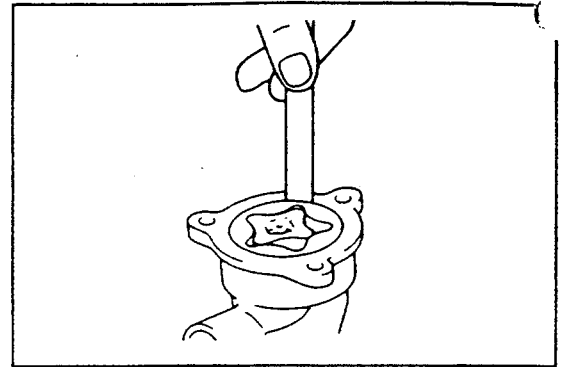

Fig. 7-7

WM-07009

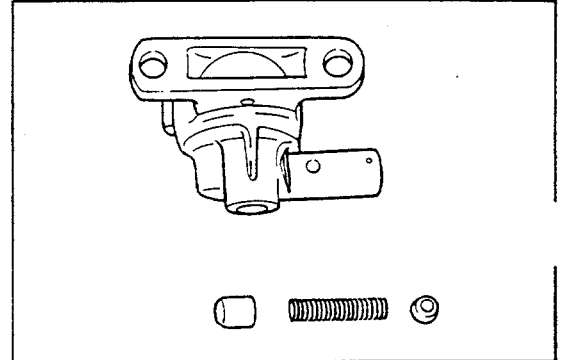

Fig. 7-8

WM-07010

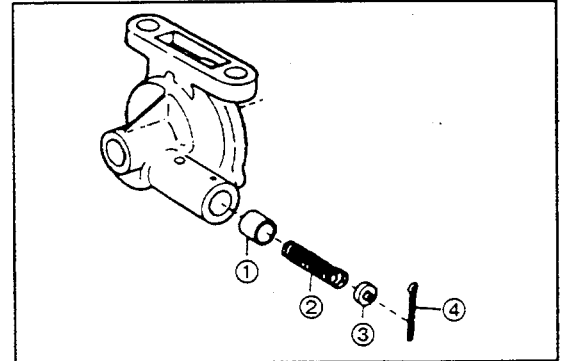

Fig. 7-9

WM-07011

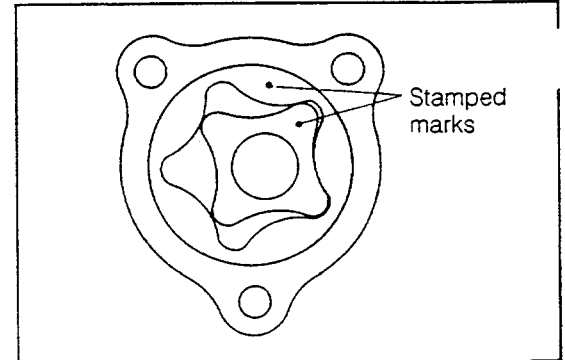

Fig. 7-10

WM-07012

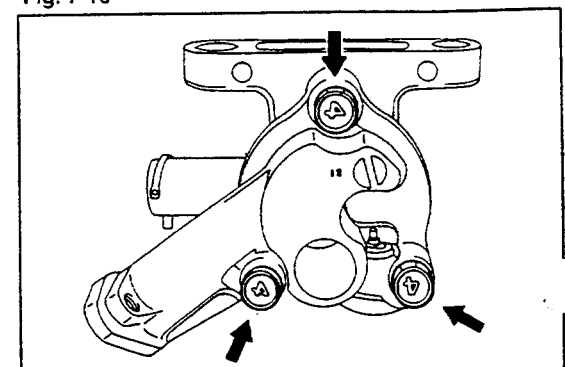

Fig. 7-11

WM-07013

Strainer

NOTE:

Replace the gasket with new one.

Tightening Torque: 0.4 - 0.7 kg-m (2.9 - 5.1 ft-lb)

Oil Pump Operation Check

5. After assembling, immerse the oil pump strainer into clean engine oil. Turn the sprocket counterclockwise. The oil should be discharged from the oil pump outlet pipe.

6. Block the outlet port with your finger and perform the same test. Ensure that the oil pump shaft becomes harder to turn until it cannot be turned any longer.

7. Attach the oil pump assembly onto the cylinder block.
Install the oil pump outlet pipe subassembly.

NOTE:

Apply engine oil to the "O" ring sections provided at both ends of the oil pump outlet pipe subassembly.

9. Install the oil pump drive shaft sprocket.

10. Inspection

Check the deflection of oil pump chain.

Measure the deflection when the center of the chain between the sprockets is pushed.

Deflection Limit: 7.0 mm (0.275 inch)

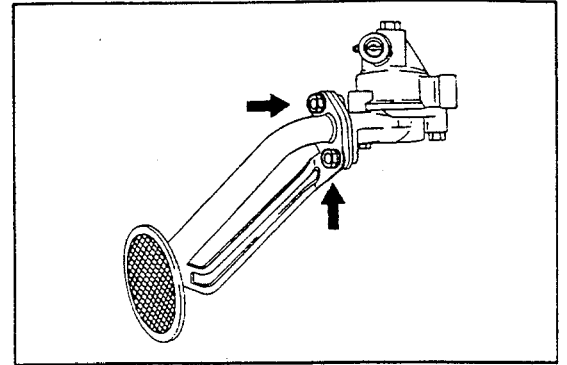

Fig. 7-12

WM-07014

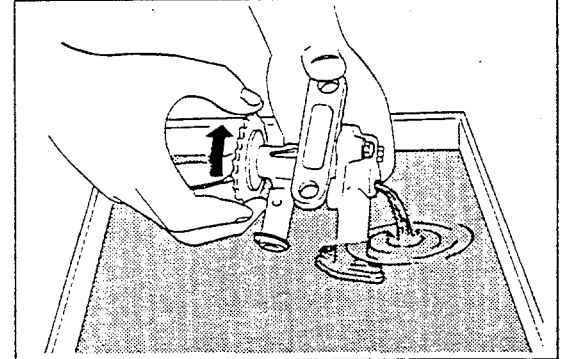

Fig. 7-13

WM-07C15

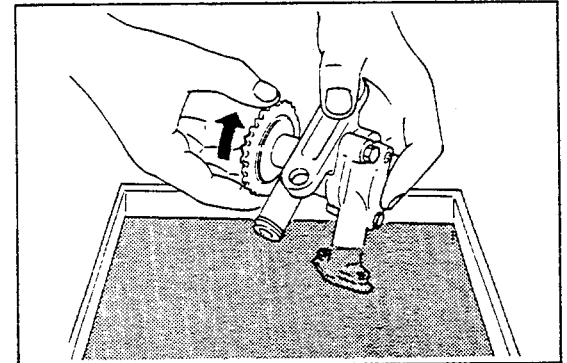

Fig. 7-14

WM-07016

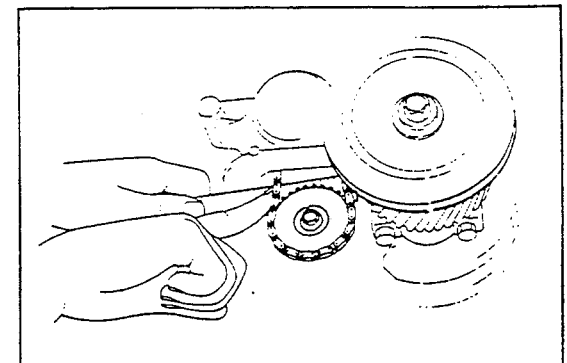

Fig. 7-15

WM-07017

LUBRICATION SYSTEM

11. Install the oil nozzle assembly. (CB-80 engine only)

NOTE:

The oil nozzle assembly can be distorted very easily. Hence, care must be exercised to ensure that the oil nozzle assembly is interfered with no other parts.

Tightening Torque: 3.0 - 3.5 kg-m (22 - 25 ft-lb)

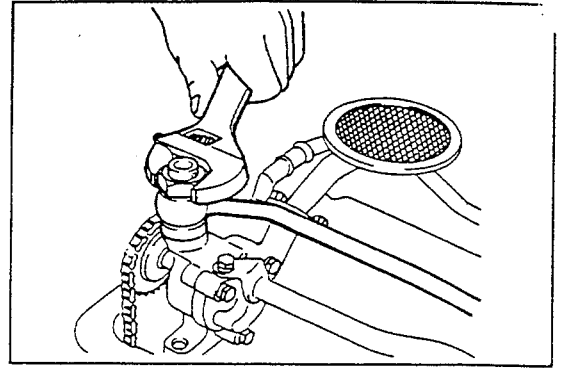
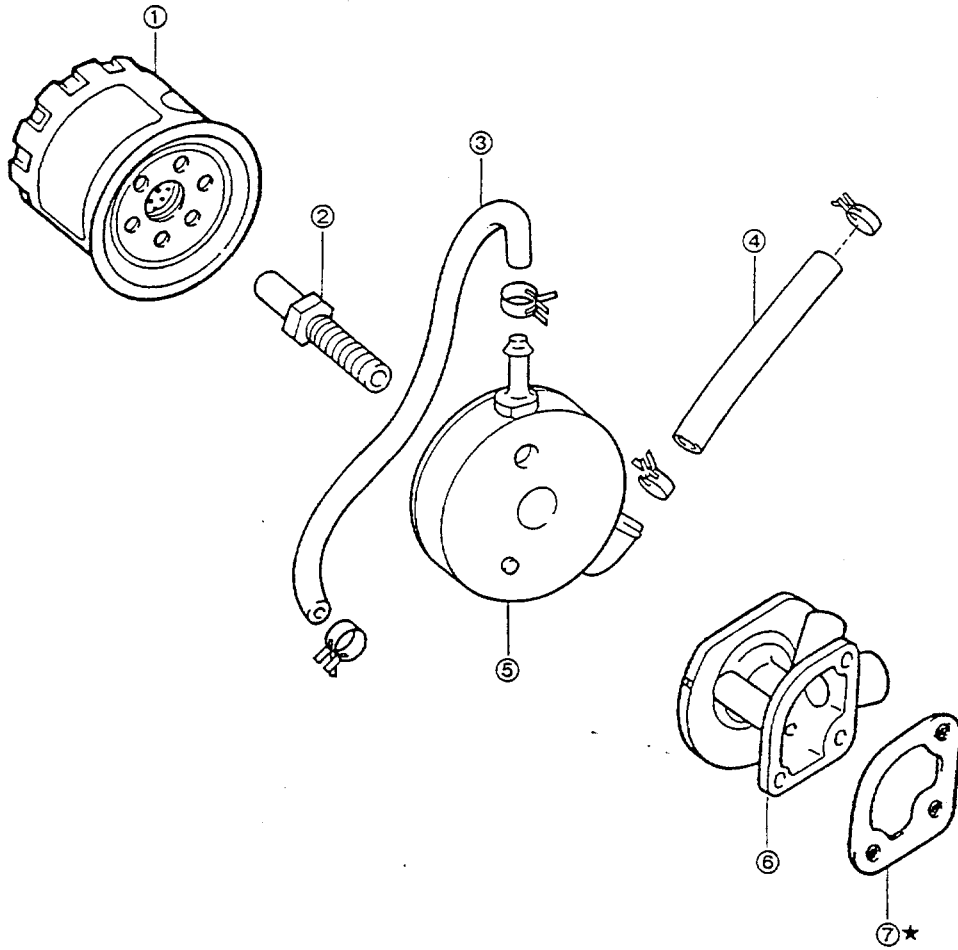

Fig. 7-16

WM-07018

OIL COOLER

COMPONENTS OF OIL COOLER [CB-61]



★: Non-reusable parts

- ① Oil filter element
- ② Oil cooler set bolt
- ③ Oil cooler hose
- ④ Oil cooler hose

- ⑤ Oil cooler
- ⑥ Oil filter bracket
- ⑦ Gasket

Fig. 7-17

LUBRICATION SYSTEM

COMPONENTS OF OIL COOLER [CB-80]

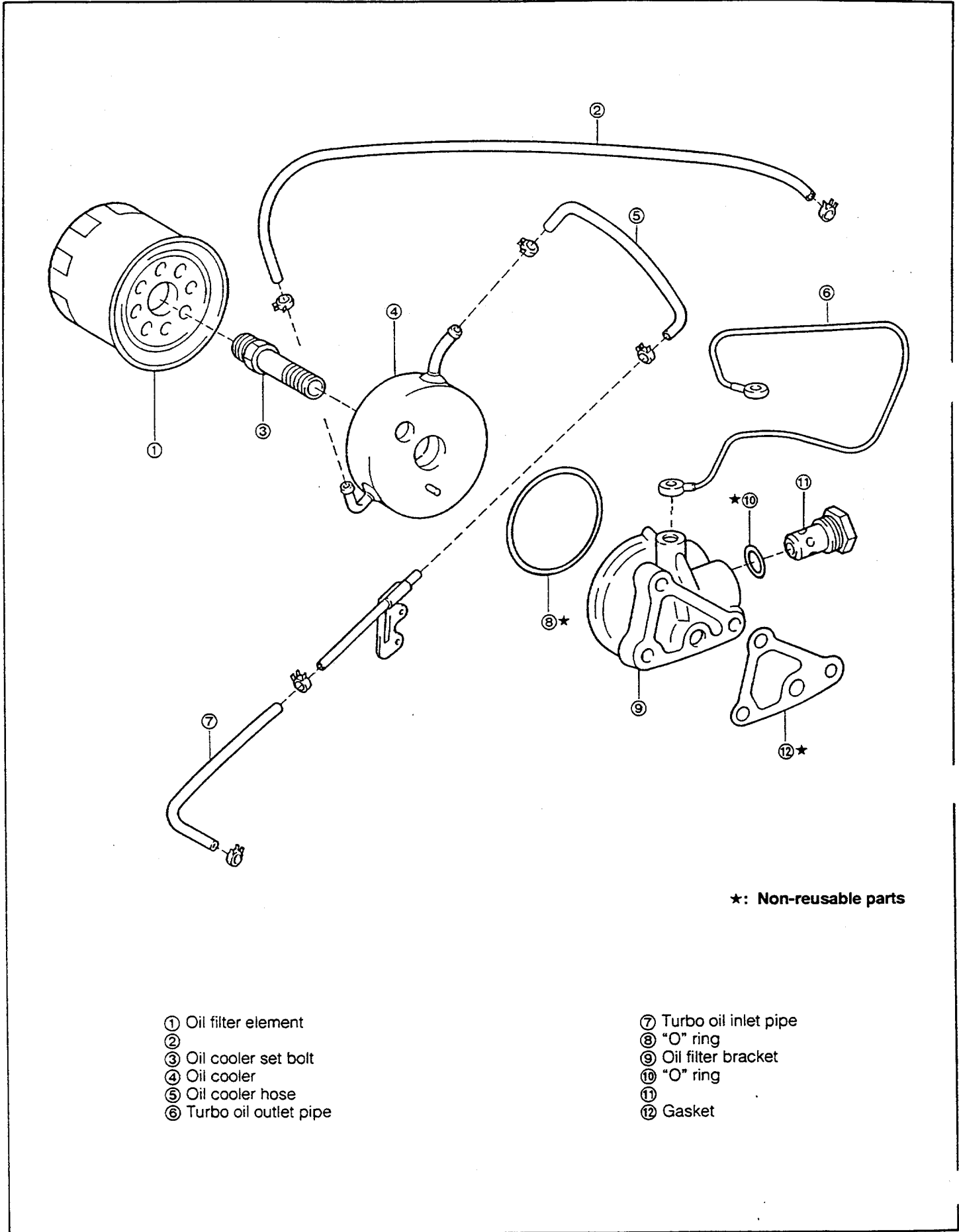

★: Non-reusable parts

- ① Oil filter element
- ② Oil cooler set bolt
- ③ Oil cooler
- ④ Oil cooler hose
- ⑤ Turbo oil outlet pipe

- ⑥ Turbo oil inlet pipe
- ⑦ "O" ring
- ⑧ Oil filter bracket
- ⑨ "O" ring
- ⑩ Gasket

Fig. 7-18

WM-07020

INSTALLATION

Oil Cooler Assembly

- (1) Make sure that the oil filter bracket is fitted with the "O" ring.
Install the oil cooler pin into the pin hole provided in the oil filter bracket.
- (2) Align the projected section of the oil filter bracket with the arrow-headed mark of the oil cooler.
- (3) Install the oil cooler set bolt.

Tightening Torque: 3.0 - 4.0 kg-m (22 - 29 ft-lb)

NOTE:

Inasmuch as the gap between the oil cooler and the set bolt is very narrow, difficulty may be encountered in installing the set bolt. In such case, the application of a small amount of engine oil to the set bolt may facilitate the installation of the said bolt.

NOTE:

Be sure to replace the gasket with a new one

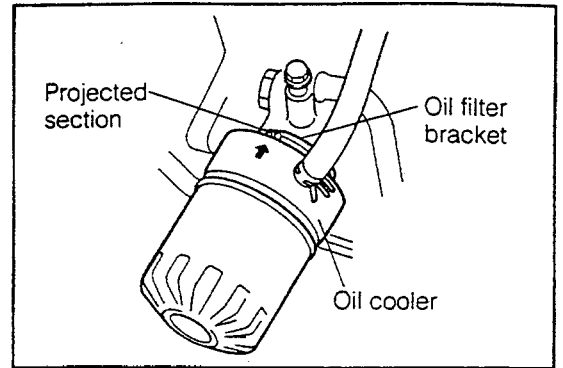

Fig. 7-19

WM-07021

INSPECTION

After the oil filter and cooler have been installed, start the engine. Make sure that the oil filter and oil cooler exhibit no oil leakage or water leakage.

WM-07022



DAIHATSU
TYPE CB
ENGINE

[CB-23, CB-61 & CB-80]

SECTION 8
COOLING SYSTEM

8

RADIATOR	8-2
IN-VEHICLE INSPECTION	8-2
RADIATOR CAP	8-2
INSPECTION	8-2
THERMOSTAT	8-3
INSPECTION	8-3
RADIATOR THERMO CONTROL SWITCH	8-4
IN-VEHICLE INSPECTION	8-4
UNIT INSPECTION	8-4
WATER PUMP	8-5
COMPONENTS OF WATER PUMP	8-5
DISASSEMBLY	8-5
INSPECTION	8-6
ASSEMBLY	8-6

WM-08001

COOLING SYSTEM

RADIATOR

IN-VEHICLE INSPECTION

Check the cooling system, following the procedure given below. Retighten or replace any part which exhibits defects.

- (1) Detach the radiator cap and fill the cooling system with cooling water. Install a cap tester.
- (2) Apply a pressure of 1.2 kg/cm² (17 psi) to the cooling system by means of the cap tester. Proceed to check the following items listed below.
 - ① Radiator leakage
 - ② Water pump leakage
 - ③ Leakage at hose connections
 - ④ Excessive hose bulge

NOTE:

Care must be exercised to ensure that the neck filler section of the radiator is not distorted while the cap tester is removed or installed, or during the test.

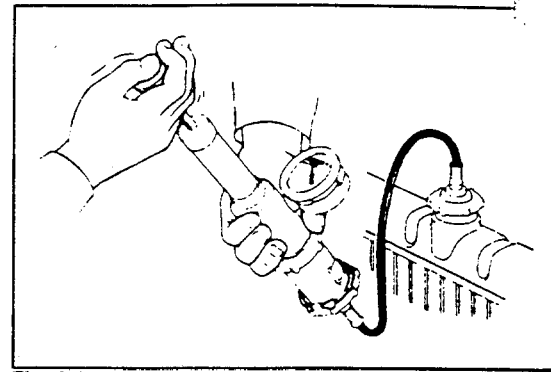

Fig. 8-1

WM-08002

- (3) Checking of neck filler section (water filling port)

- ① Distorted or dented seal surface
- ② Distorted edge section

NOTE:

If the neck filler section is distorted, the radiator cap can not be seated on the neck filler section closely, resulting in a decrease in the water level.

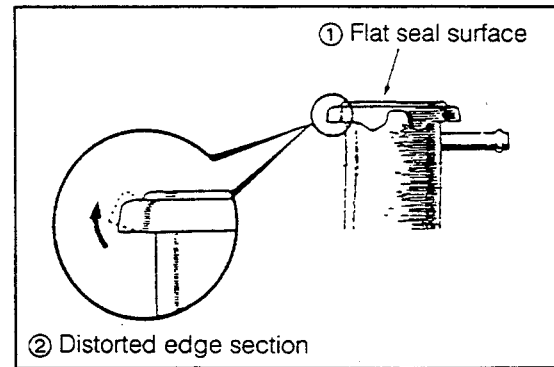

Fig. 8-2

WM-08003

RADIATOR CAP

INSPECTION

- (1) Check the following parts. Replace any part which exhibits defects.

- ① Cranked or distorted seal packing
- ② Distorted or dented valve or valve seat
- ③ Water scale accumulation between valve and valve seat

NOTE:

Remove any water scale accumulation which is found between the valve and the valve seat.

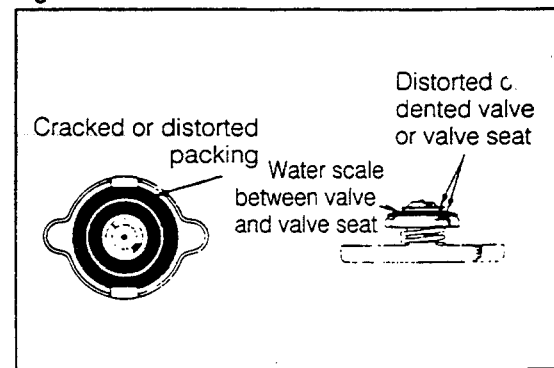

Fig. 8-3

WM-08004

) Check the pressure sealing and vacuum relief valve operation:

Valve Opening Pressure Limit: kg/cm² (psi)

CB-23	0.6 (8.5)
CB-61	0.6 (8.5)
CB-80	0.6 (8.5)

Standard Valve: kg/cm² (psi)

CB-23	0.75 - 1.05
CB-61	0.75 - 1.05
CB-80	0.75 - 1.05

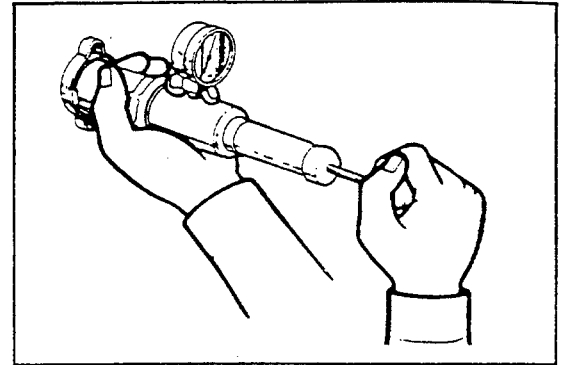

Fig. 8-4

WM-08005

THERMOSTAT INSPECTION

(1) Immerse the thermostat in water, and check the valve opening temperature by heating the water gradually.

(2) Replace the thermostat if the valve remains open at normal temperature or is not very tight when fully closed.

Specifications	Valve opening temperature (°C)	Valve total lift (mm)
Except ECE & EEC Specifications	80.5 - 83.5	8 mm or more at 95 °C
ECE & EEC Specifications	86.5 - 89.5	8 mm or more at 100 °C

CAUTION:

As for Type CB-80 engine, install the thermostat in such a way that the jiggle pin may come at the upper side of the cylinder head. Failure to observe this caution may cause overheat or seizure of the engine.

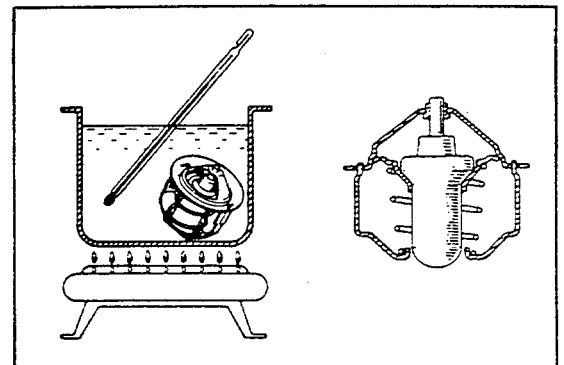

Fig. 8-5

WM-08006

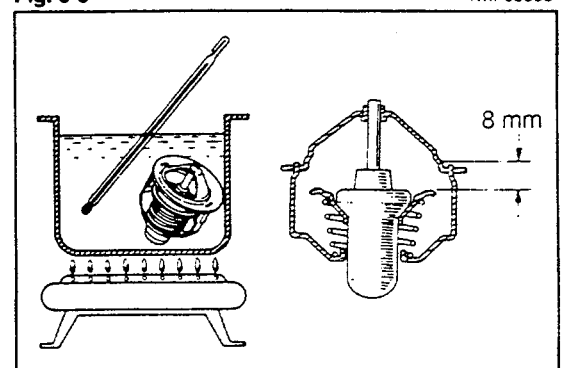

Fig. 8-6

WM-08007

COOLING SYSTEM

RADIATOR THERMO CONTROL SWITCH IN-VEHICLE INSPECTION

- (1) Turn ON the ignition switch.
- (2) Disconnect the radiator thermo control switch terminal and ground it directly to the body.
Confirm that the fan motor can turn.

UNIT INSPECTION

- (1) Connect a circuit tester to the radiator thermo control switch.
Under this setting, change the water temperature. Observe the behavior of the circuit tester's pointer. If the pointer of the tester behaves as follows, it represents that the radiator thermo control switch is functioning normally.

- (2) Radiator thermo control switch characteristics

① General and Australian specifications

When the cooling temperature reaches $92 \pm 2^{\circ}\text{C}$, the radiator thermo control switch starts to operate. When the cooling water temperatures begins to drop, the radiator thermo control switch continues to function until the cooling water temperature drops to $87 \pm 2^{\circ}\text{C}$.

② ECE & EEC Specifications

When the cooling temperature reaches $98 \pm 2^{\circ}\text{C}$, the radiator thermo control switch starts to operate. When the cooling water temperatures begins to drop, the radiator thermo control switch continues to function until the cooling water temperature drops to $93 \pm 2^{\circ}\text{C}$.

Fan Motor

Connection of fan motor to battery

[Connect the positive \oplus terminal of the motor to the positive \oplus terminal of the battery.]

[Connect the negative \ominus terminal of the motor to the negative \ominus terminal of the battery.]

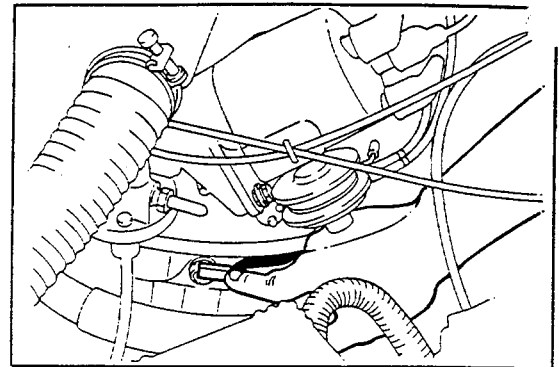

Fig. 8-7

WM-08008

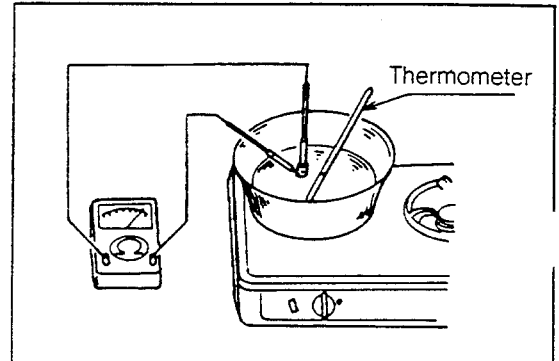

Fig. 8-8

WM-08009

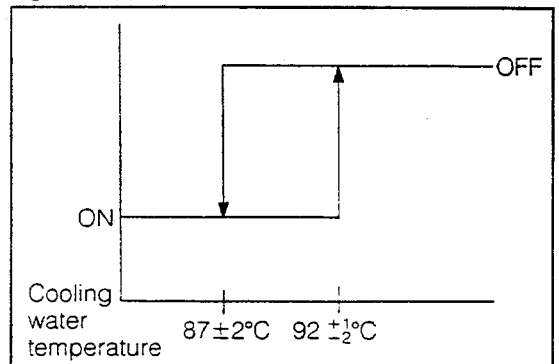

Fig. 8-9

WM-08010

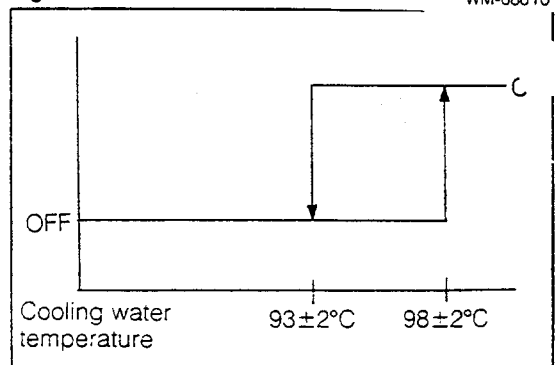

Fig. 8-10

WM-08011

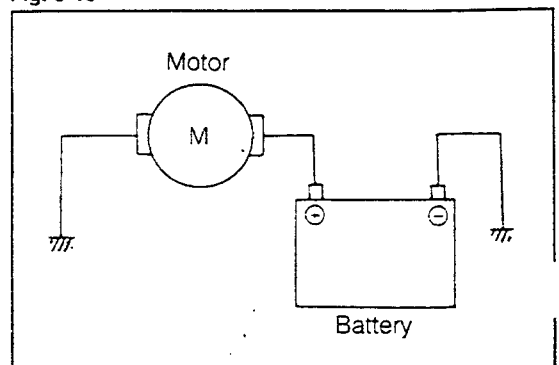

Fig. 8-11

WM-08012

WATER PUMP

COMPONENTS OF WATER PUMP

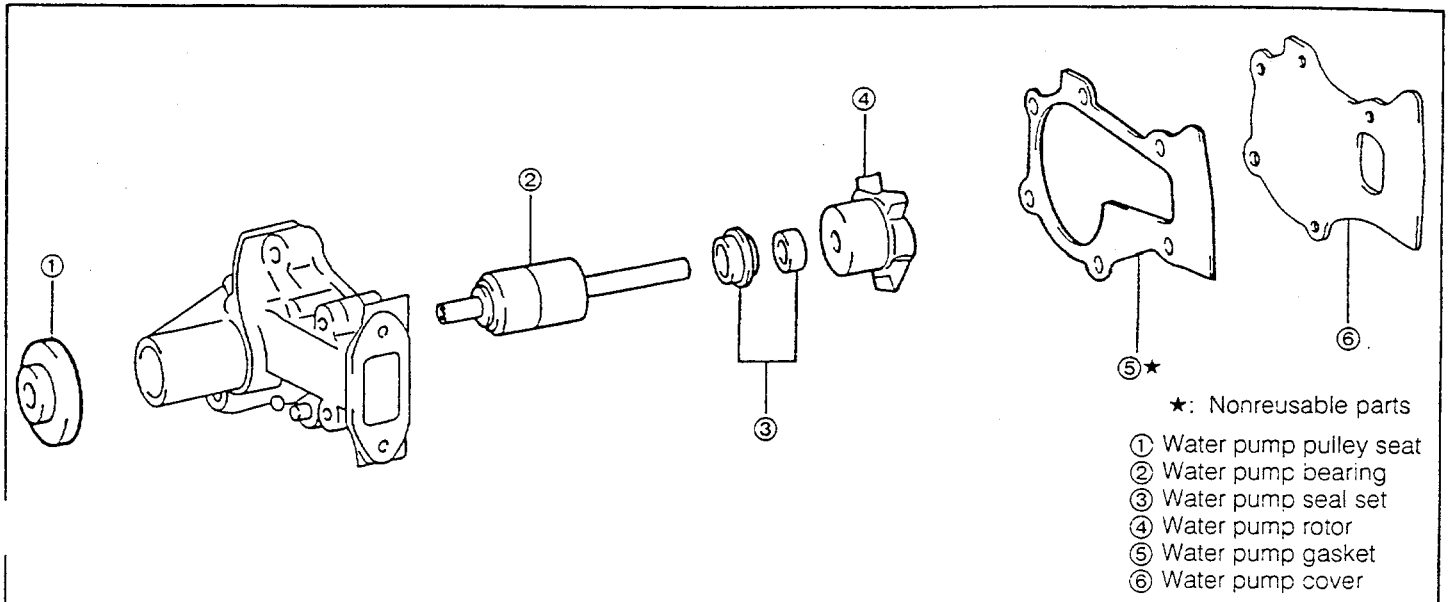

Fig. 8-12

WM-08013

DISASSEMBLY

1. Press off the water pump pulley, using the following SSTs.

SST: 09253-87202-000

SST: 09238-87201-000

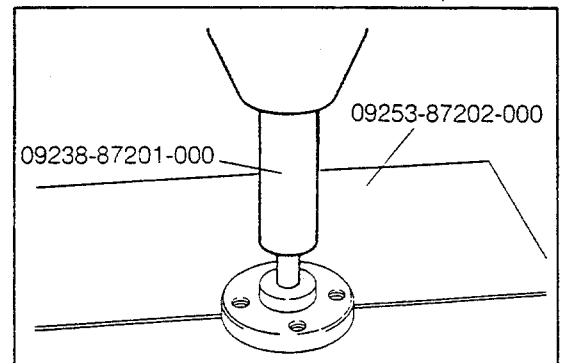

Fig. 8-13

WM-08014

2. Remove the water pump bearing, using the following SST.

SST: 09237-87201-000

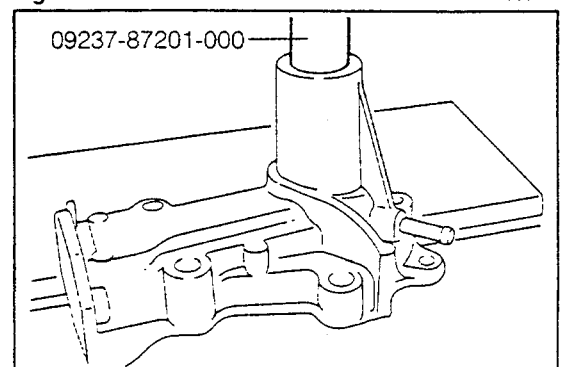

Fig. 8-14

WM-08015

3. Remove the rotor and seal set from the water pump bearing, using the following SST.

SST: 09238-87201-000

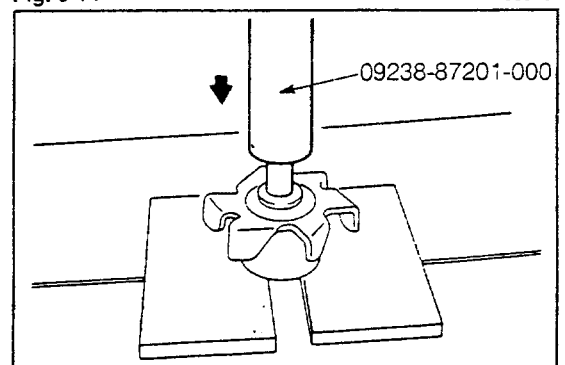

Fig. 8-15

WM-08016

COOLING SYSTEM

INSPECTION

1. Check the water pump rotor and water pump seal set for evidence of damage or wear.
Replace any parts that show defects.
2. Inspect the water pump bearing for damage, abnormal sound, or improper rotation.
Replace the bearing that exhibits defects.
3. Check the water inlet pipe "O" ring for deterioration or damage. Replace the "O" ring that indicates defects.

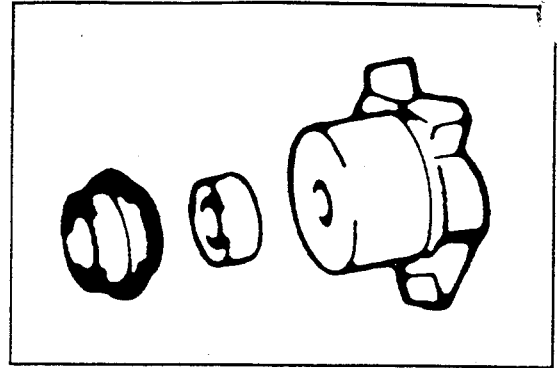

Fig. 8-16

WM-08017

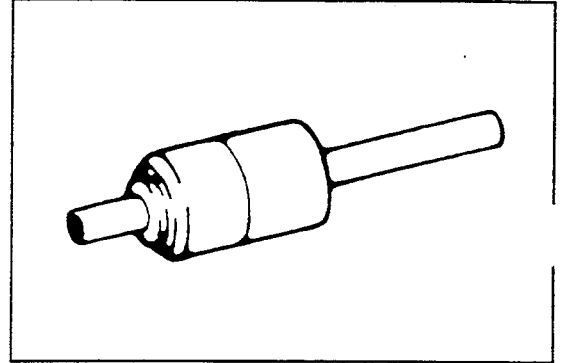

Fig. 8-17

WM-08018

ASSEMBLY

1. Press the bearing into water pump rotor, using the following SST.
SST: 09237-87201-000
2. Press the water pump set with the rotor into position, using the following SSTs.
SST: 09238-87201-000
SST: 09238-87701-000
3. Press the water pump rotor into position, using the following SST.
SST: 09238-87201-000

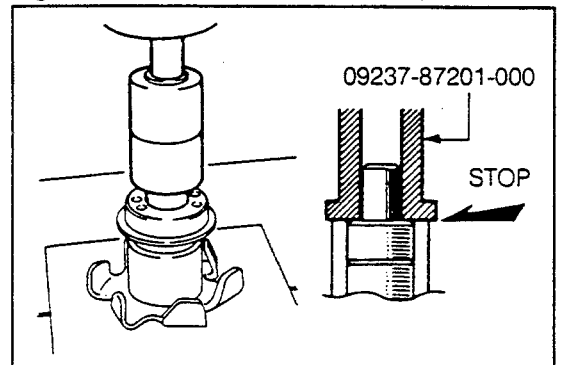

Fig. 8-18

WM-08019

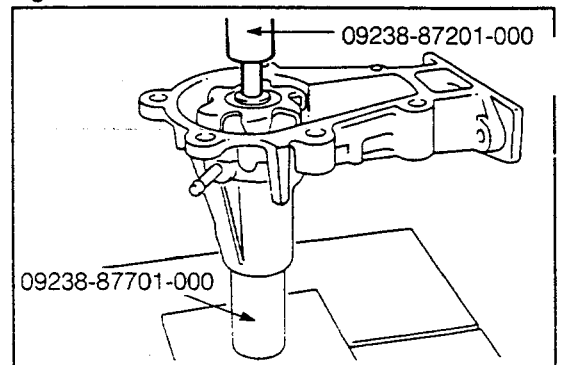

Fig. 8-19

WM-08020

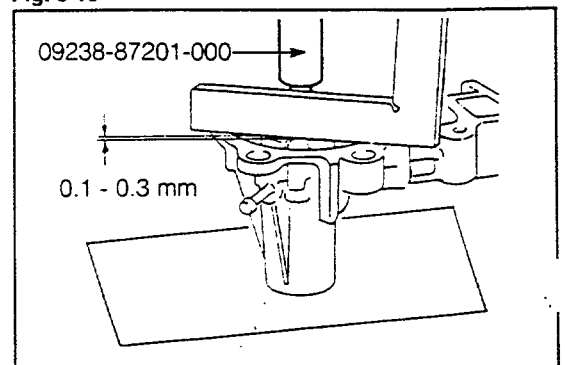

Fig. 8-20

WM-08021

Press the water pump bearing set into the water pump pulley seat, using the following SSTs.

SST: 09238-87201-000

SST: 09254-87201-000

5. After assembling, make sure the rotor rotates smoothly with the water pump seat in the installed condition.

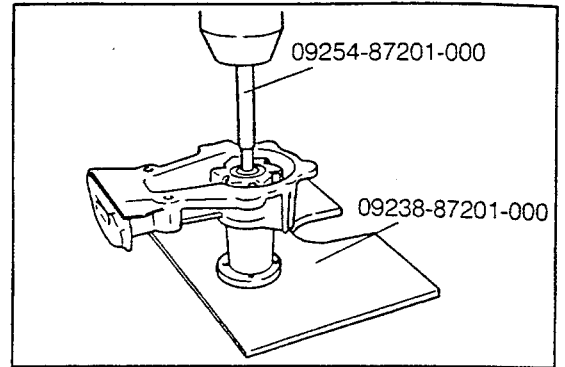

Fig. 8-21

WM-08022

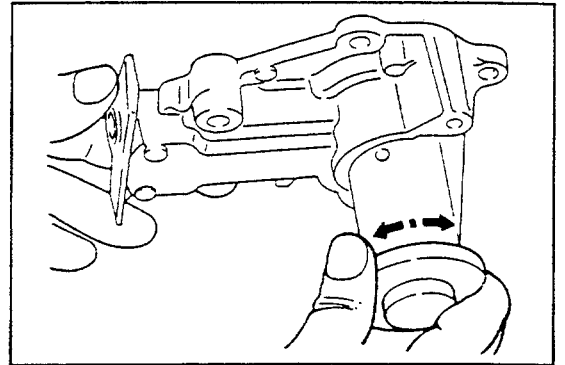

Fig. 8-22

WM-08023



DAIHATSU
TYPE CB
ENGINE

[CB-23, CB-61 & CB-80]

SECTION 9

TURBOCHARGER SYSTEM

TURBOCHARGER	9-2
COMPONENTS OF TURBO CHARGER	
[CB-61 & CB-81 Engines]	9-2
INSPECTION ON TURBOCHARGED RELATED	
OPERATION	9-3
INSPECTION	9-4
IN-VEHICLE INSPECTION	9-4
TROUBLE SHOOTING	9-6

WM-09001

9

TURBOCHARGER SYSTEM

TURBOCHARGER

COMPONENTS OF TURBOCHARGER [CB-61 & CB-80 Engines]

NOTE:
The removal of the turbocharger should be performed only after the temperature of the turbocharger has dropped sufficiently.

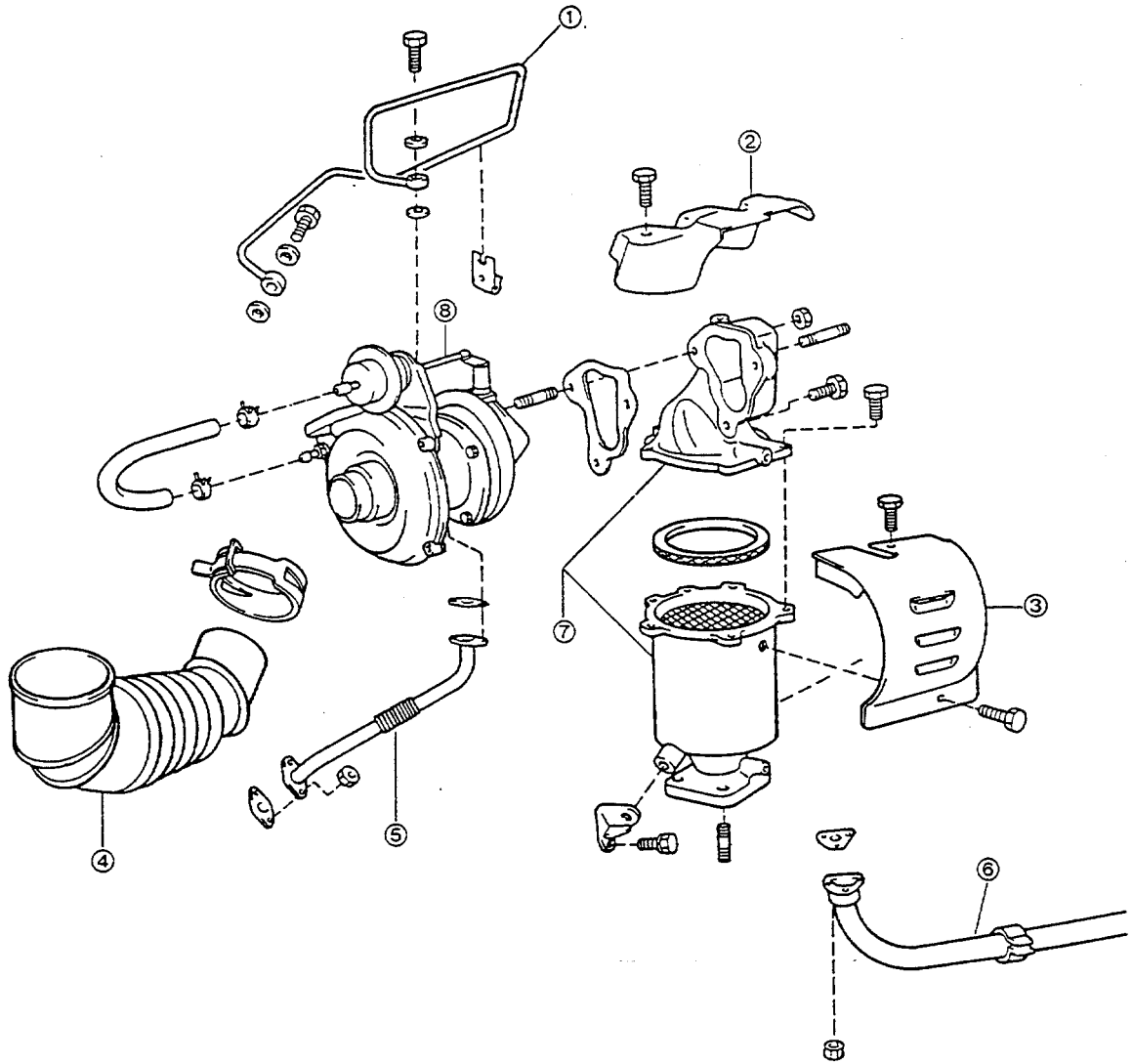

- | | |
|---|-------------------------|
| ① Turbo oil inlet pipe | ⑤ Turbo oil outlet pipe |
| ② Exhaust manifold heat insulator No. 1 | ⑥ Exhaust front pipe |
| ③ Exhaust manifold heat insulator No. 2 | ⑦ Exhaust manifold case |
| ④ Air cleaner hose | ⑧ Turbocharger |

Fig. 9-1

WM-09002

INSTRUCTIONS ON TURBOCHARGER-RELATED OPERATIONS

1. The turbocharger is a precision component whose assembly requires special attention and equipment. Hence, never try to disassemble it.
2. When turbocharger is removed or installed:
 - (1) When the turbocharger has been removed, special care must be exercised as to the removed turbocharger.
 - (2) When the turbocharger is removed and installed, the oil inlet and outlet ports of the turbocharger and its inlet and outlet ports of intake air and exhaust gases should be plugged using adhesive tape, etc. in order that no dust or foreign particle may enter into the turbocharger.
 - (3) When the intake system, exhaust system or lubrication system is disassembled, make sure that no dust or foreign particle be permitted to enter into the turbocharger.
Furthermore, ensure that the tightening torque specifications are strictly observed during the installation of the turbocharger so that the turbocharger may exhibit no leakage.
 - (4) When the engine is started after the turbocharger has been replaced, be sure to run the engine idly for at least 10 seconds. If the engine revolution speed is increased too sharply, the bearings of the turbocharger may be damaged.
Also, make sure that no oil is leaking from the oil pipe.

3. Never try to lift the turbocharger by holding the waste gate valve rod or the similar parts.

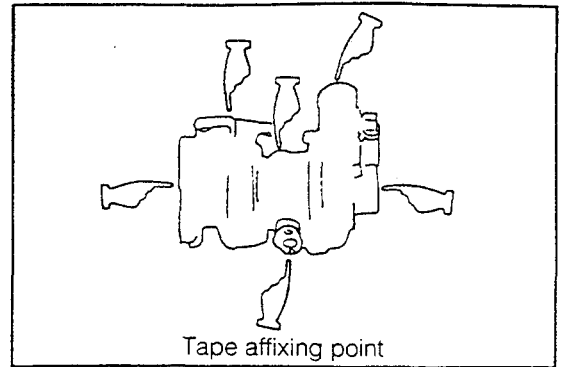

Fig. 9-2

WM-09003

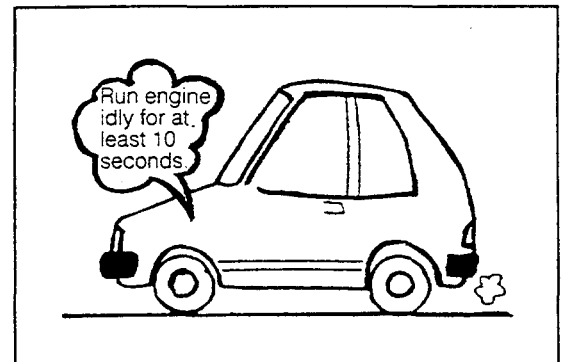

Fig. 9-3

WM-09004

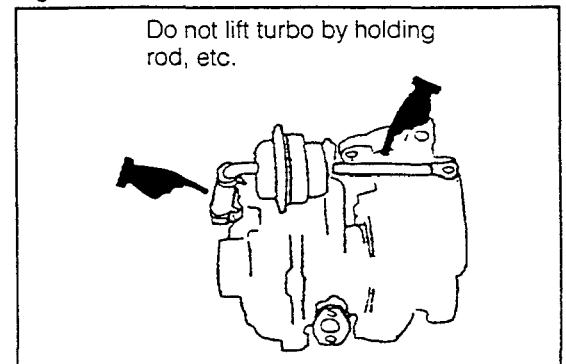

Fig. 9-4

WM-09005

TURBOCHARGER SYSTEM

4. Be very careful not to drop the turbocharger, for it is a precision component.
5. Never try to wipe off the residual oil completely from the bearing.
(Here, the residual oil refers to such a degree of sticking oil which appears after the natural flowing.)
6. Be sure not to touch the turbocharger immediately after the engine operation or during the engine operation.
(Failure to observe this caution may incur a burn.)
7. Do not run the engine with the intake pipe, intake hose, or exhaust manifold case, etc. disconnected.
(This notice is important to prevent the ingress of any foreign matter.)

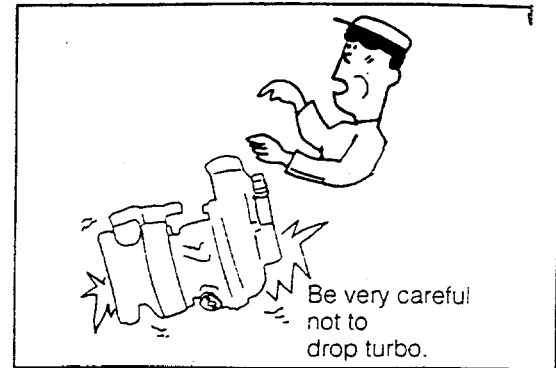

Fig. 9-5

WM-09006

INSPECTION

Checking of Lubrication System

1. Remove the union bolt for turbocharger lubrication use. Check to see if the orifice is restricted. If the orifice exhibits any restriction, clean the orifice, using compressed air.

NOTE

1. Be sure to replace the union bolt washer with a new part.
2. Apply engine oil to the union bolt during the assembly.

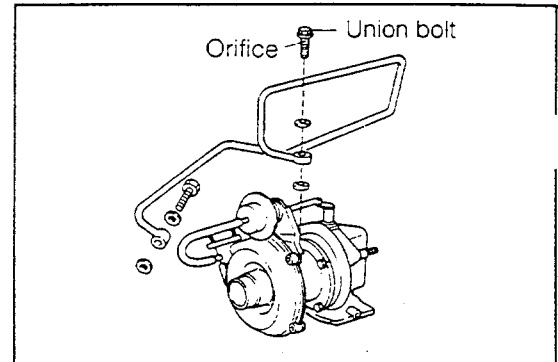

Fig. 9-6

WM-09007

Checking of Turbocharger

1. Check the blades of the turbine and compressor for any evidence of damage.
2. When the blades are turned by your finger, ensure that the turbine and compressor rotate smoothly.
3. Make sure that neither the turbine side nor the compressor side exhibits oil leakage.

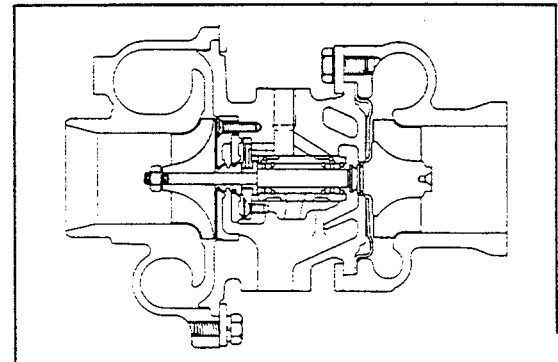

Fig. 9-7

WM-09008

IN-VEHICLE INSPECTION

Checking of Operation of Waste Gate Valve

1. Disconnect the waste gate actuator hose at the actuator side.
2. Connect a turbocharger pressure gauge and apply a pressure of 0.65 kg/cm^2 (9.2 psi) [CB-61, 80]. Ensure that the rod and link are functioning properly.

Turbocharger pressure gauge:
SST [0992-87703-000]

When the pressure is released, ensure that the rod and link return to the original position without any binding.

3. Check to see if the hose exhibits cracks or damage.

NOTE:

If any pressure in excess of 0.7 kg/cm^2 (10.0 psi) is applied to the waste gate actuator, there is a possibility that the diaphragm may be damaged.

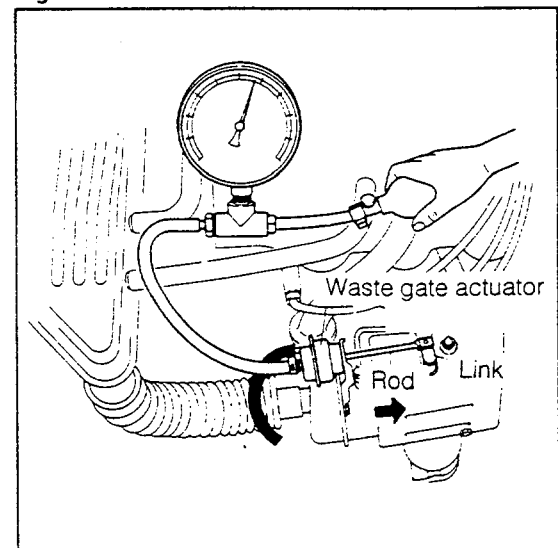

Fig. 9-8

WM-09009

Checking of Supercharging Pressure of Turbocharger (Running Test)

NOTE:

This running test should be carried out in a test site where the acceleration running with the secondary valve fully opened and the transmission placed in the second gear may be performed safely. Moreover, conduct this running test with two persons riding on the test vehicle.

WM-09010

1. (CB-61 Engine)

Disconnect the surge tank hose. Connect a three-way joint and turbocharger pressure gauge. Place the pressure gauge in the vehicle interior.

Turbocharger pressure gauge:
SST [09992-87703-000]

(CB-80 Engine)

Disconnect the vacuum hose of the VSV (for controlling the supercharging pressure). Attach a three-way joint between the VSV and the vacuum switch (turbo indicator). Measure the supercharging pressure, using a pressure gauge.

Turbocharger pressure gauge:
SST [09992-87703-000]

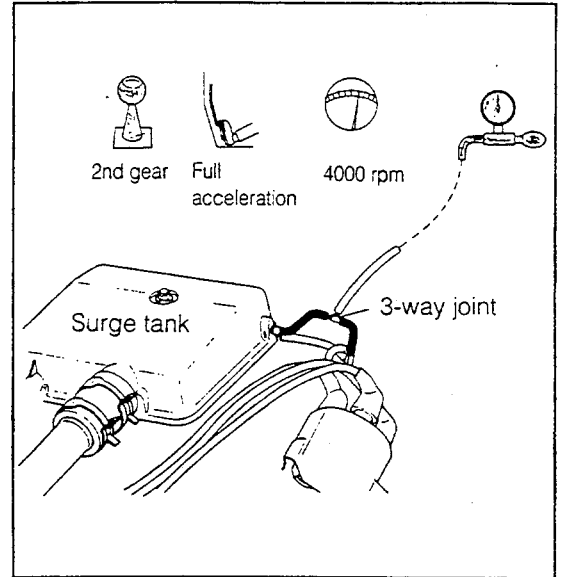

Fig. 9-9

WM-09011

2. After warming-up the engine, perform a full acceleration running test with the transmission place in the second gear, until the engine revolution speed reaches 4000 rpm.
3. Check the pressure at the time when the engine revolution speed reaches 4000 rpm.

Specified Pressure: CB-61 Engine 0.4 - 0.6 kg/cm² (5.7 - 8.5 psi)
CB-80 Engine 0.6 kg/cm² (8.5 psi) or more

If the pressure fails to conform to the specification, replace the turbocharger assembly.

NOTE:

Be sure not to perform the adjustment or disassembly of the turbocharger.

WM-09012

TURBOCHARGER SYSTEM

TROUBLE SHOOTING (CB-61)

NOTE:

1. Prior to starting the trouble shooting, make sure that the engine has been tuned-up properly and the idling adjustment has been performed to the specification.
2. Also, ensure that the engine is warmed up thoroughly.

1. Engine fails to deliver sufficient engine output.

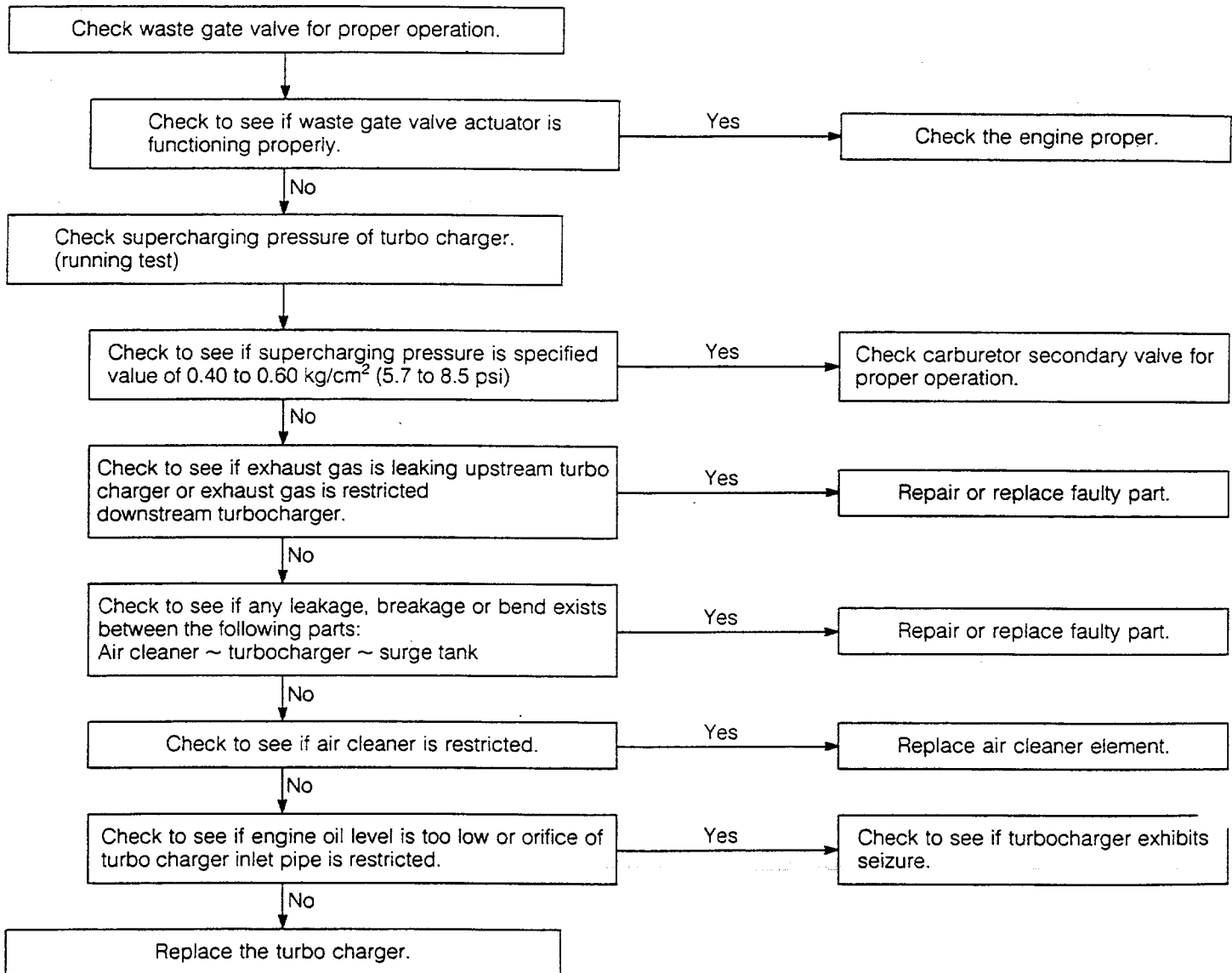

WM-09013

Knocking or hunting occurs when engine runs at 3000 to 4000 rpm with throttle valve opened fully and with transmission place in second gear.

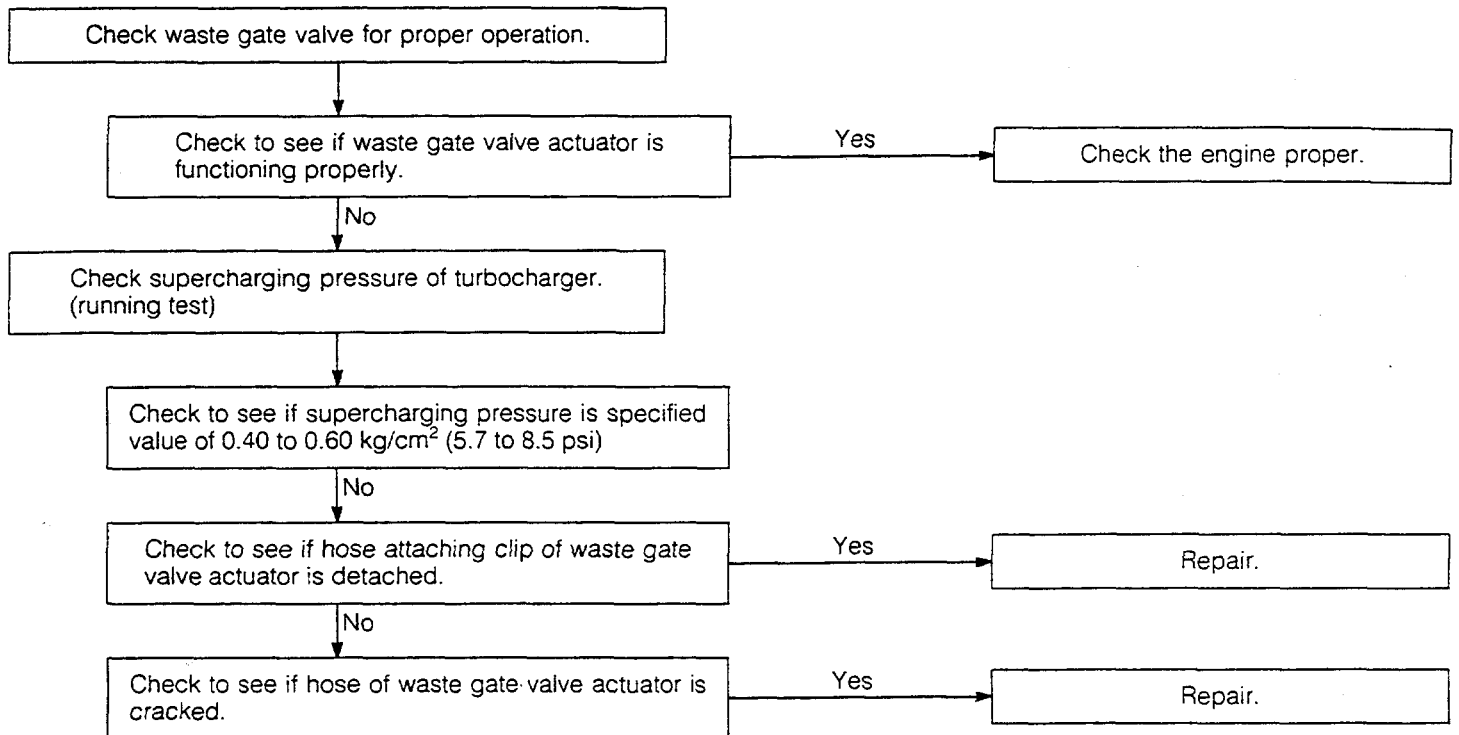

WM-09014

3. Engine emits whitish exhaust gas or oil is emitted from tail pipe.

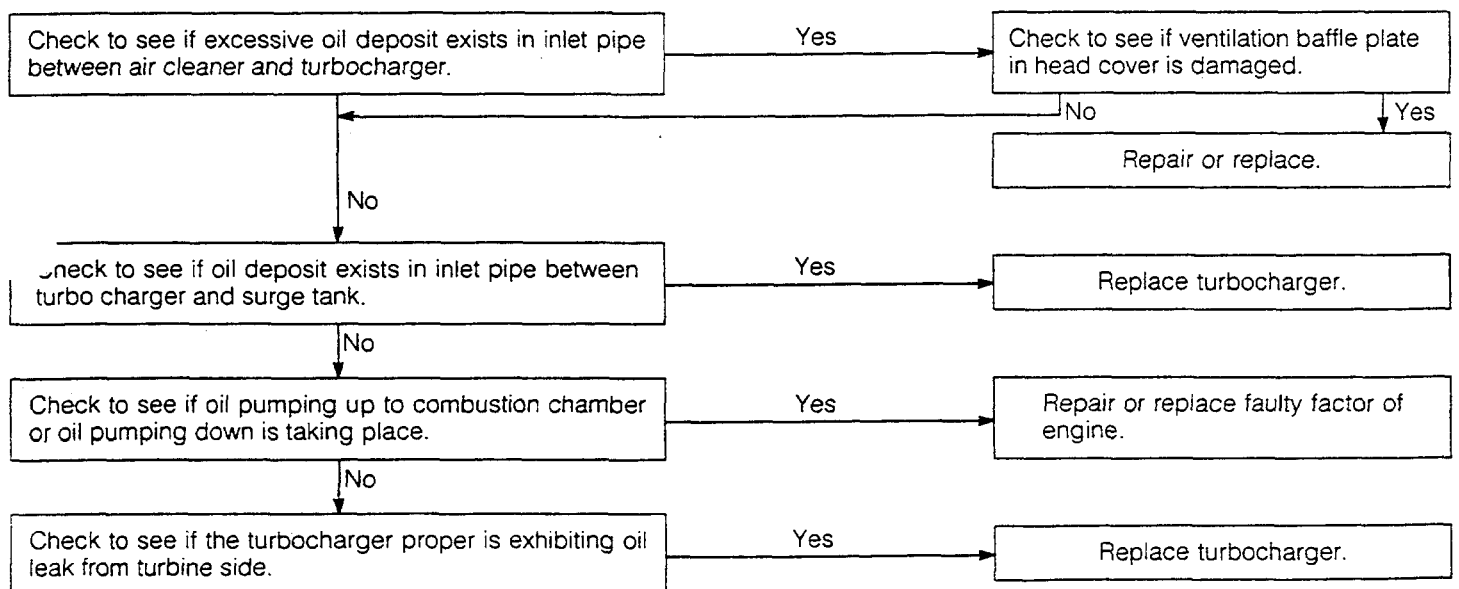

WM-09015



DAIHATSU TYPE CB ENGINE

[CB-23, CB-61 & CB-80]

SECTION 10 ENGINE ELECTRICAL SYSTEM

DISTRIBUTOR	10- 2
COMPONENTS OF DISTRIBUTOR	
[CB-23 & CB-61 Engines]	10- 2
DISASSEMBLY [CB-23 & CB-61 Engines]	10- 3
INSPECTION [CB-23 & CB-61 Engines]	10- 4
INSPECTION [CB-80 Engine]	10- 5
ASSEMBLY [CB-23 & CB-61]	10- 5
IGNITION SYSTEM	10- 7
COMPONENTS OF IGNITION SYSTEM	
INSPECTION [CB-23 & CB-61 Engines]	10- 8
STARTER	10-10
COMPONENTS OF STARTER	
[CB-23 M/T, CB-61 Engine & CB-80 Engine with General Specification]	10-10
[CB-23 Engine A/T & CB-80 Engine with ECE & EEC Specification]	10-11
PERFORMANCE TEST	10-12
DISASSEMBLY	
[CB-23 Engine M/T and CB-61 & CB-80 Engines]	10-14
DISASSEMBLY [CB-23 Engine A/T]	10-15
INSPECTION	10-16
ASSEMBLY	
[CB-23 Engine M/T and CB-61 & CB-80 Engines]	10-19
ASSEMBLY [CB-23 Engine A/T]	10-21
ALTERNATOR	10-23
COMPONENTS OF ALTERNATOR	
DISASSEMBLY	10-24
INSPECTION	10-24
ASSEMBLY	10-25
IN-VEHICLE INSPECTION	10-26

WM-10001

ENGINE ELECTRICAL SYSTEM

DISTRIBUTOR

COMPONENTS OF DISTRIBUTOR [CB-23 & CB-61 Engines]

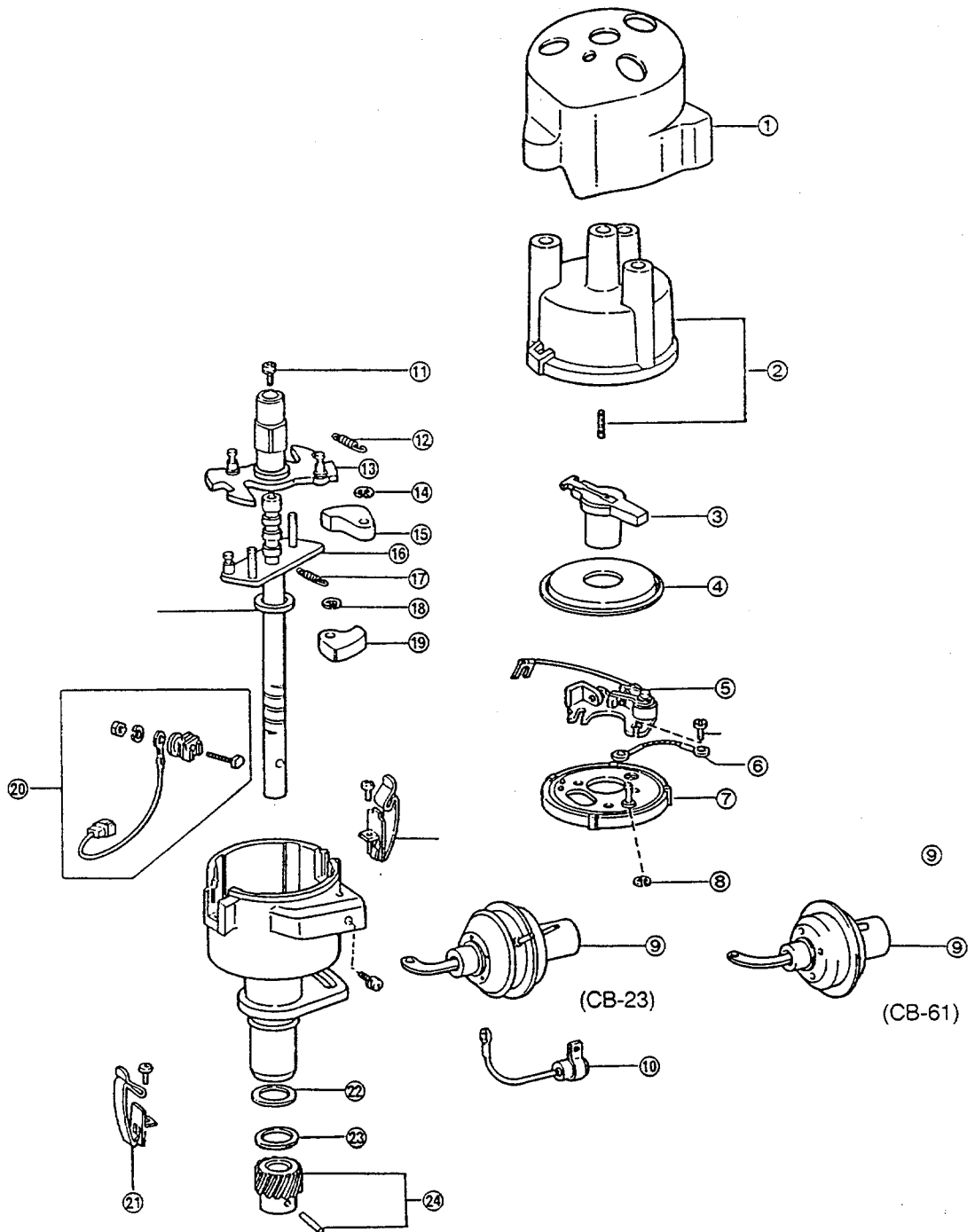

- | | | |
|--------------------------------|--------------------|--------------------------|
| ① Water-proof cover | ⑨ Vacuum advancer | ⑰ Governor spring |
| ② Distributor cap | ⑩ Condenser | ⑱ Snap washer |
| ③ Distributor rotor | ⑪ Screw and washer | ⑲ Governor weight |
| ④ Dust-proof distributor cover | ⑫ Governor spring | ⑳ Distributor terminal |
| ⑤ Breaker points kit | ⑬ Distributor cam | ㉑ Distributor cap spring |
| ⑥ Wire | ⑭ Snap washer | ㉒ "O" ring |
| ⑦ Stationary plate | ⑮ Governor weight | ㉓ Plate washer |
| ⑧ Washer | ⑯ Governor shaft | ㉔ Spiral gear |

Fig. 10-1

WM-10002

SASSEMBLY [CB-23 & CB-61 Engine]

1. Remove the distributor cap.
2. Remove the rotor, cover and packing.
3. Remove the terminal nut, lead wire condenser, insulators and terminal.

4. Remove the two screws and breaker points.

5. Remove the vacuum advance.
 - (1) Remove the condenser mounting screw and condenser from the distributor housing.
 - (2) Remove the E-ring. Turn and pull out the vacuum advancer.

6. Remove the breaker plate.
 - (1) Remove the two screws, ground wire and plate washers.
 - (2) Pull out the breaker plate. Remove the governor springs.

7. Remove the cam.
 - (1) Pry out the grease stopper.
 - (2) Remove the screw at the top of the governor shaft.
 - (3) Pull out the cam and governor weights.

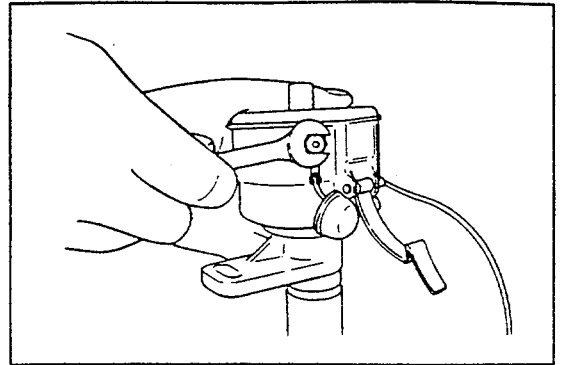

Fig. 10-2

WM-10003

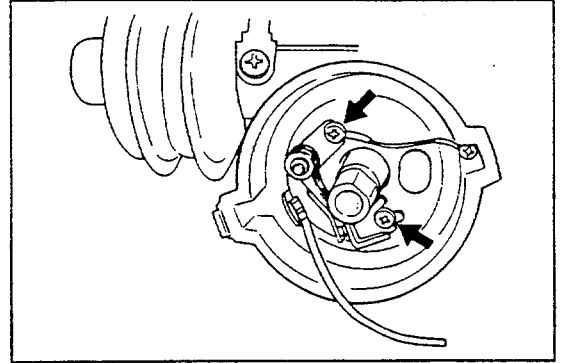

Fig. 10-3

WM-10004

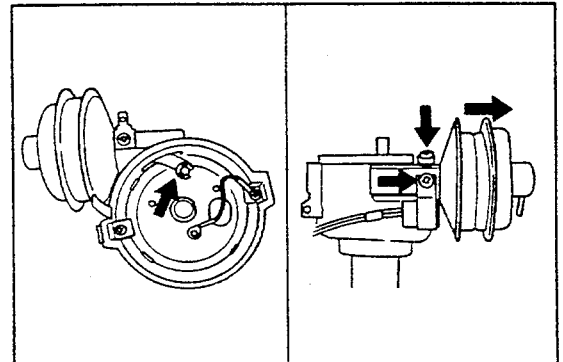

Fig. 10-4

WM-10005

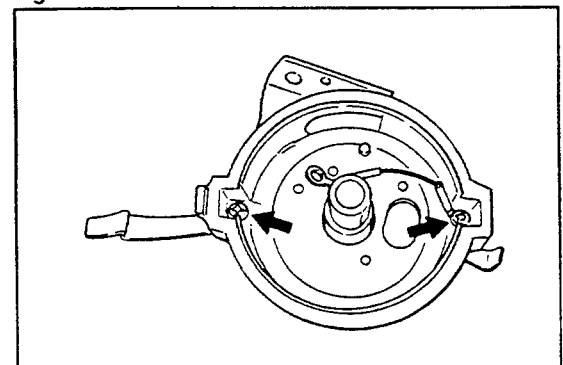

Fig. 10-5

WM-10006

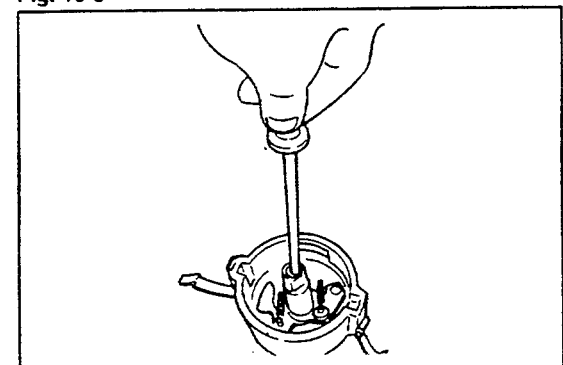

Fig. 10-6

WM-10007

ENGINE ELECTRICAL SYSTEM

INSPECTION [CB-23 & CB-61 Engine]

1. Cap
Check the cap for cracks, rust, dirty or corroded terminal.
Check the central section for wear.
2. Rotor
Check the rotor for cracks, burnt state, dirt or corrosion.
3. Breaker plate
Turn the breaker plate. Ensure that it has a slight drag.
If strong resistance or sticking is felt, replace the breaker plate.
4. Governor
Temporarily install the cam with governor to the governor shaft. Ensure that they fit correctly.
Replace the cam with governor or the housing kit, as required.
5. Breaker points
Check the breaker points for wear or damage.
6. Governor shaft and housing
Check for wear, sticking or damage. Replace the housing kit, as required.

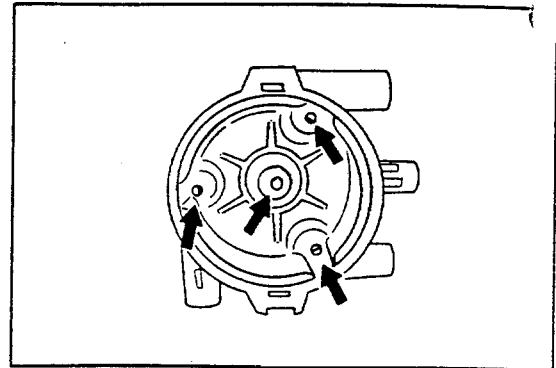

Fig. 10-7

WM-10008

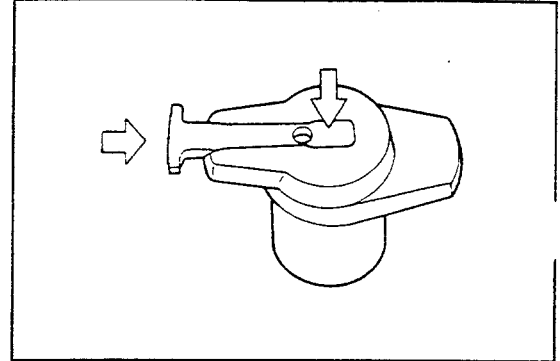

Fig. 10-8

WM-10009

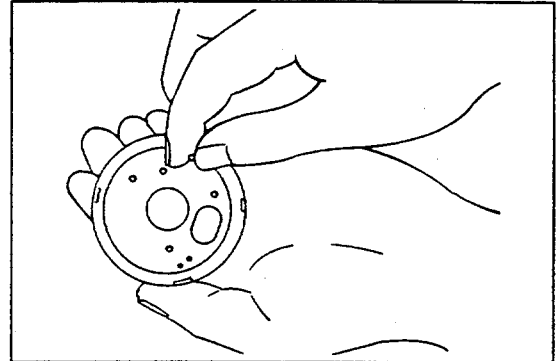

Fig. 10-9

WM-10010

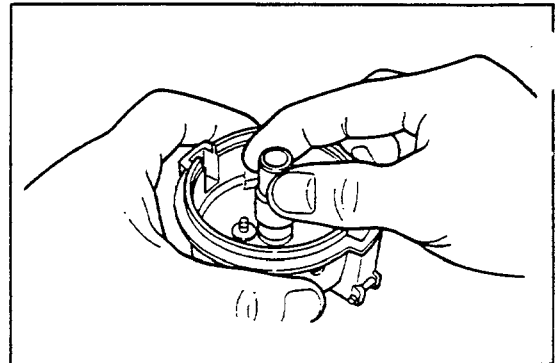

Fig. 10-10

WM-10011

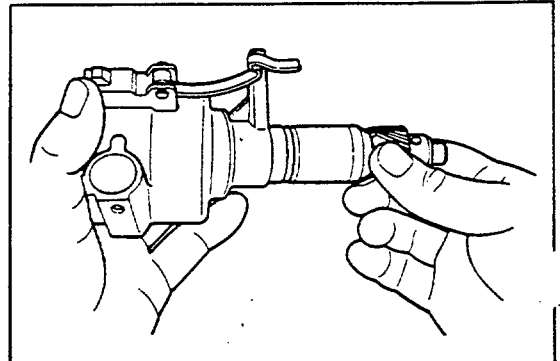

Fig. 10-11

WM-10012

INSPECTION [CB-80 Engine]

Measure the resistance between the terminals specified in the right figure.

Specified Value

Resistance between Terminals ① and ②:
140 - 180 Ω

Resistance between Terminals ③ and ④:
140 - 180 Ω

Cap

Check the cap for cracks, rust, dirty or corroded terminal.
Check the central section for wear.

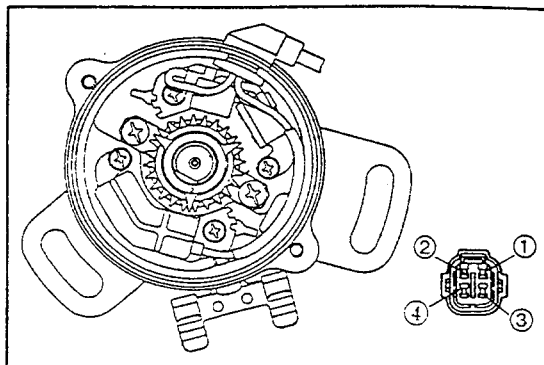

Fig. 10-12

WM-10013

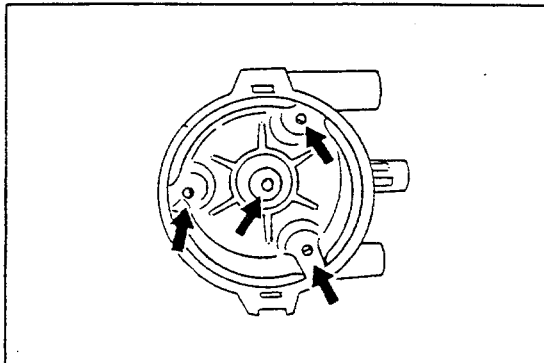

Fig. 10-13

WM-10013A

ASSEMBLY [CB-23 & CB-61]

1. Install the cam with governor weights.
 - (1) Install the screw.
 - (2) Pack the high-temperature grease into the shaft.
 - (3) Push on the grease stopper by your finger.

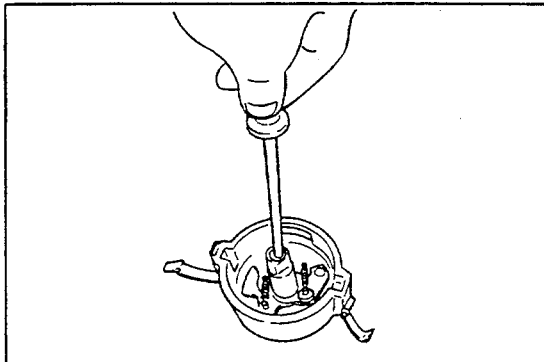

Fig. 10-14

WM-10014

- (4) Install the cam with governor weights.
- (5) Install the governor spring.

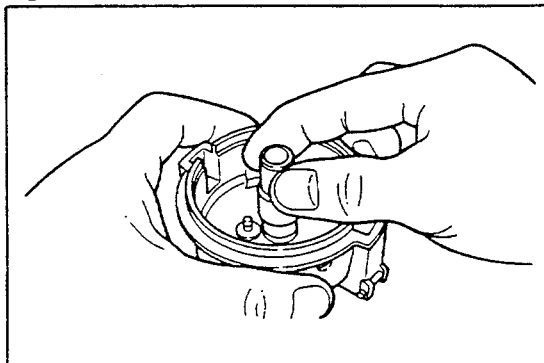

Fig. 10-15

WM-10015

2. Install the breaker plate.
 - (1) Fit the four clips on the governor plate into the housing slots.
 - (2) Install one end of the lead wire and two plate washers with screws.

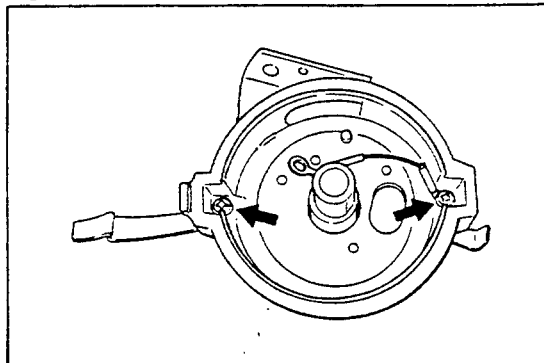

Fig. 10-16

WM-10016

ENGINE ELECTRICAL SYSTEM

3. Install the vacuum advancer.
 - (1) Insert the advancer into the distributor and position the lever hole over the plate pin.
 - (2) Install the E-ring on the pin.
 - (3) Install the screw with the condenser to the distributor body.

4. Install and adjust the breaker point.
 - (1) Clean the contact surfaces of the points with a piece of cloth saturated in solvent.
 - (2) Loosely install the breaker points and one end of the lead wire with two screws.
 - (3) Using a feeler gauge set the heel gap and tighten the two screws.
Heel gap: 0.45 mm (0.0177 inch)

5. Install the lead wire and terminal.

Insert the terminal with breaker points wire. Install the insulators, lead wire, condenser and terminal nut.
6. Install the rotor.
7. Install the distributor cap and packing.

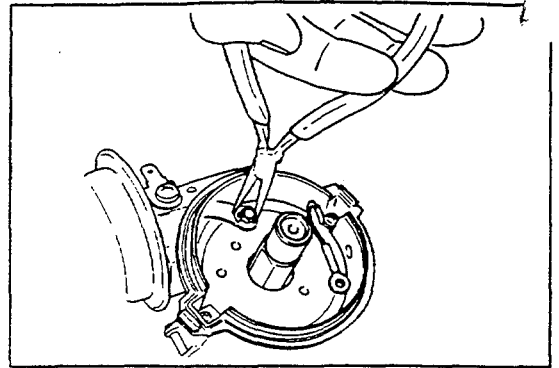

Fig. 10-17

WM-10017

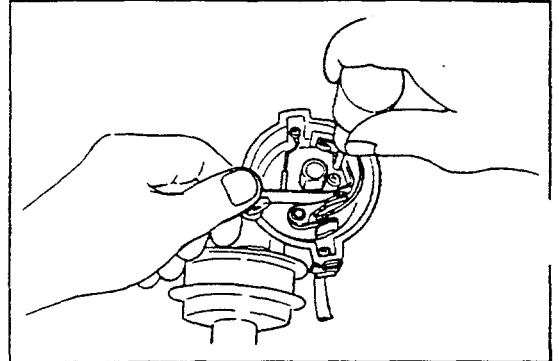

Fig. 10-18

WM-10018

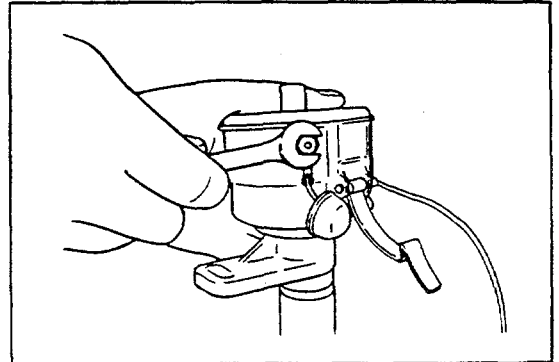
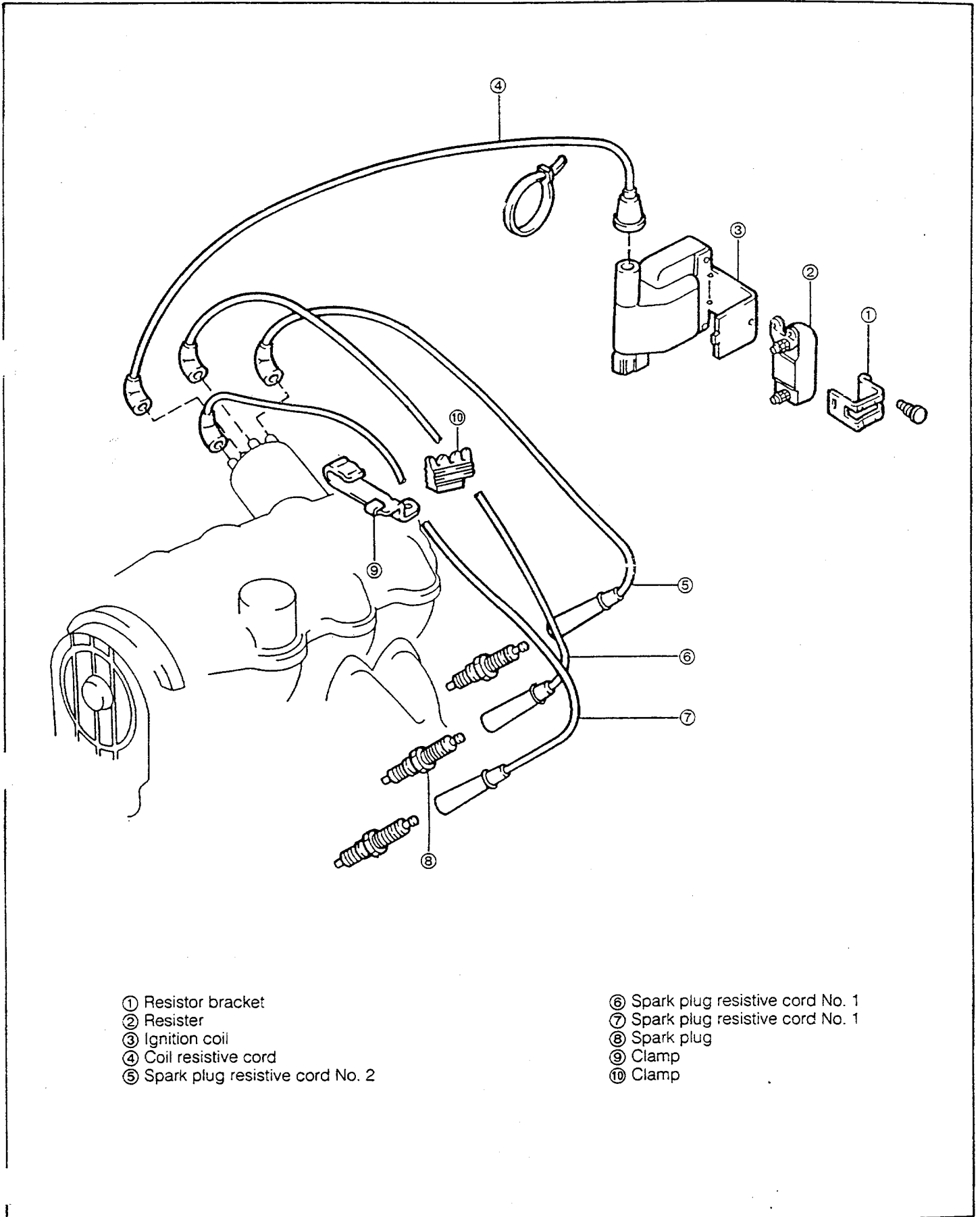

Fig. 10-19

WM-10019

IGNITION SYSTEM

COMPONENTS OF IGNITION SYSTEM



- ① Resistor bracket
- ② Resistor
- ③ Ignition coil
- ④ Coil resistive cord
- ⑤ Spark plug resistive cord No. 2

- ⑥ Spark plug resistive cord No. 1
- ⑦ Spark plug resistive cord No. 1
- ⑧ Spark plug
- ⑨ Clamp
- ⑩ Clamp

Fig. 10-20

WM-10020

ENGINE ELECTRICAL SYSTEM

INSPECTION [CB-23 & CB-61 Engine]

1. Ignition coil

(1) Primary coil resistance measurement

Measure the resistance between the positive (+) terminal and the negative (-) terminal.

Resistance: 0.9 - 1.1 Ω

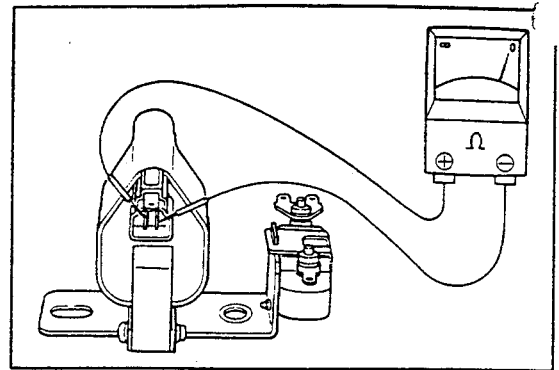

Fig. 10-21

WM-10021

(2) Secondary coil resistance measurement

Measure the resistance between the positive (+) terminal and the high tension terminal.

Resistance: 20.7 - 25.3 k Ω

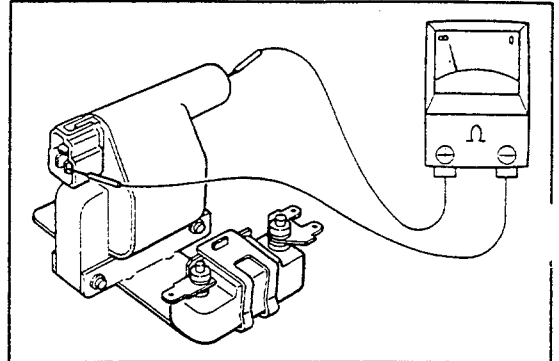

Fig. 10-22

WM-10022

(3) Insulator resistance measurement

Measure the resistance between the positive (+) terminal and the coil case.

Resistance: Infinity

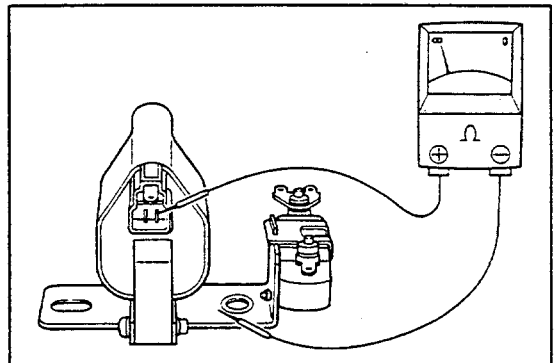

Fig. 10-23

WM-10023

(4) Resistor resistance measurement

Resistance: 1.53 - 1.87 Ω

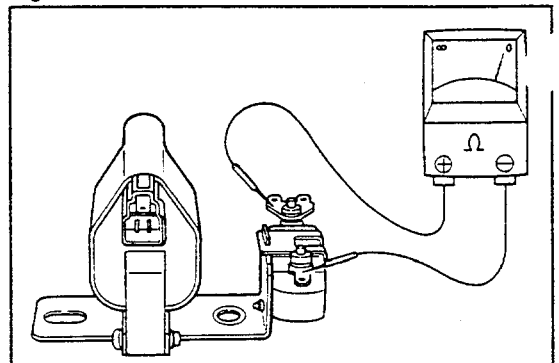

Fig. 10-24

WM-10024

High tension cord check

- Carefully remove the high tension cord holding the rubber boot.

NOTE:

Pulling out or bending the cord may damage the inner conductor.

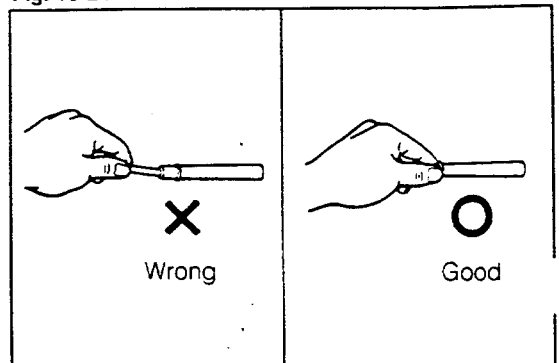

Fig. 10-25

WM-10029

ENGINE ELECTRICAL SYSTEM

Measure the resistance of each high tension cord.

Resistance:

	CB-23 engine	CB-61 engine	CB-80 engine
Cord No.1	6.8 - 10.0	6.8 - 10.0	3.2 - 4.8
Cord No.2	8.1 - 12.1	8.1 - 12.1	4.6 - 7.0
Cord No.3	8.1 - 12.1	8.1 - 12.1	7.0 - 10.3
Central cord	6.1 - 9.2	6.1 - 9.2	5.1 - 7.7

Spark plugs

- Remove the spark plug.
- Clean and check the spark plug.
 - Clean the spark plug with a plug cleaner or wire brush.
 - Inspect the spark plug to see if any damage is present at the electrode wire, thread or insulator.
- Adjust the electrode gap. Carefully bend the outer electrode to obtain the correct electrode gap.

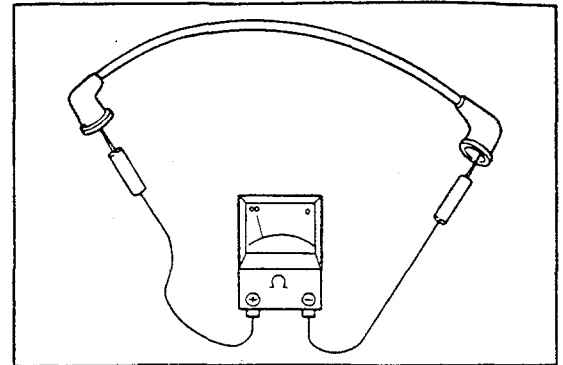

Fig. 10-26

WM-10030

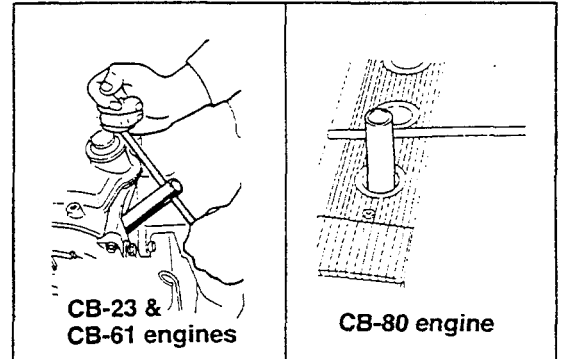

Fig. 10-27

WM-10031

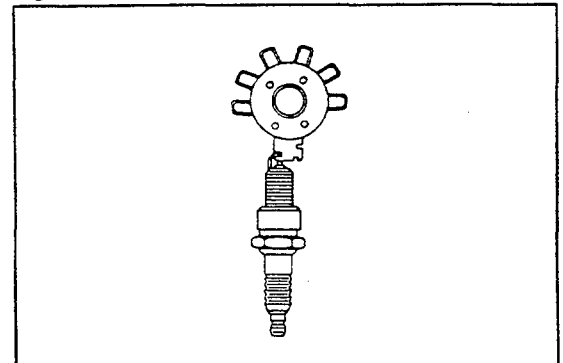

Fig. 10-28

WM-10032

Spark Plug Specifications

The type	CB-23					CB-61				CB-80	
	DENSO	NGK		BOSCH	CHAMPION	DENSO	NGK	BOSCH	CHAMPION	DENSO	
ECE & EEC Specifications	W16EXR-U	BPR5EA-L	BPR5EY	WR8DC	RN-11YC	W16EXR-U W20EXR-U	BPR5EY BPR6EY	WR8DC WR7DC	RN-9YC RN-11YC	W20ETR-L	W22ETR-L
Except ECE & EEC Specifications	W16EX-U	BP5EA-L	BP5EY	W8DC (X,Y)	N-11YC	W16EX-U W20EX-U	BP5EY BP6EY	W8DC (X,Y) W7DC (X,Y)	N-9YL N-11YC	W20ET-L	W22ET-L
Spark plug gap mm (inch)	0.7 - 0.8 (0.028 - 0.031)	0.8 - 0.9 (0.031 - 0.036)	0.7 - 0.8 (0.028 - 0.031)	0.7 - 0.8 (0.028 - 0.031)	0.7 - 0.8 (0.028 - 0.031)	0.8 - 0.9 (0.032 - 0.036)	0.7 - 0.8 (0.028 - 0.031)	0.9 - 1.0 (0.035 - 0.039)			

- Install the spark plugs.

WM-10033

ENGINE ELECTRICAL SYSTEM

STARTER

COMPONENTS OF STARTER

[CB-23 M/T, CB-61 Engine & CB-80 Engine with General Specification]

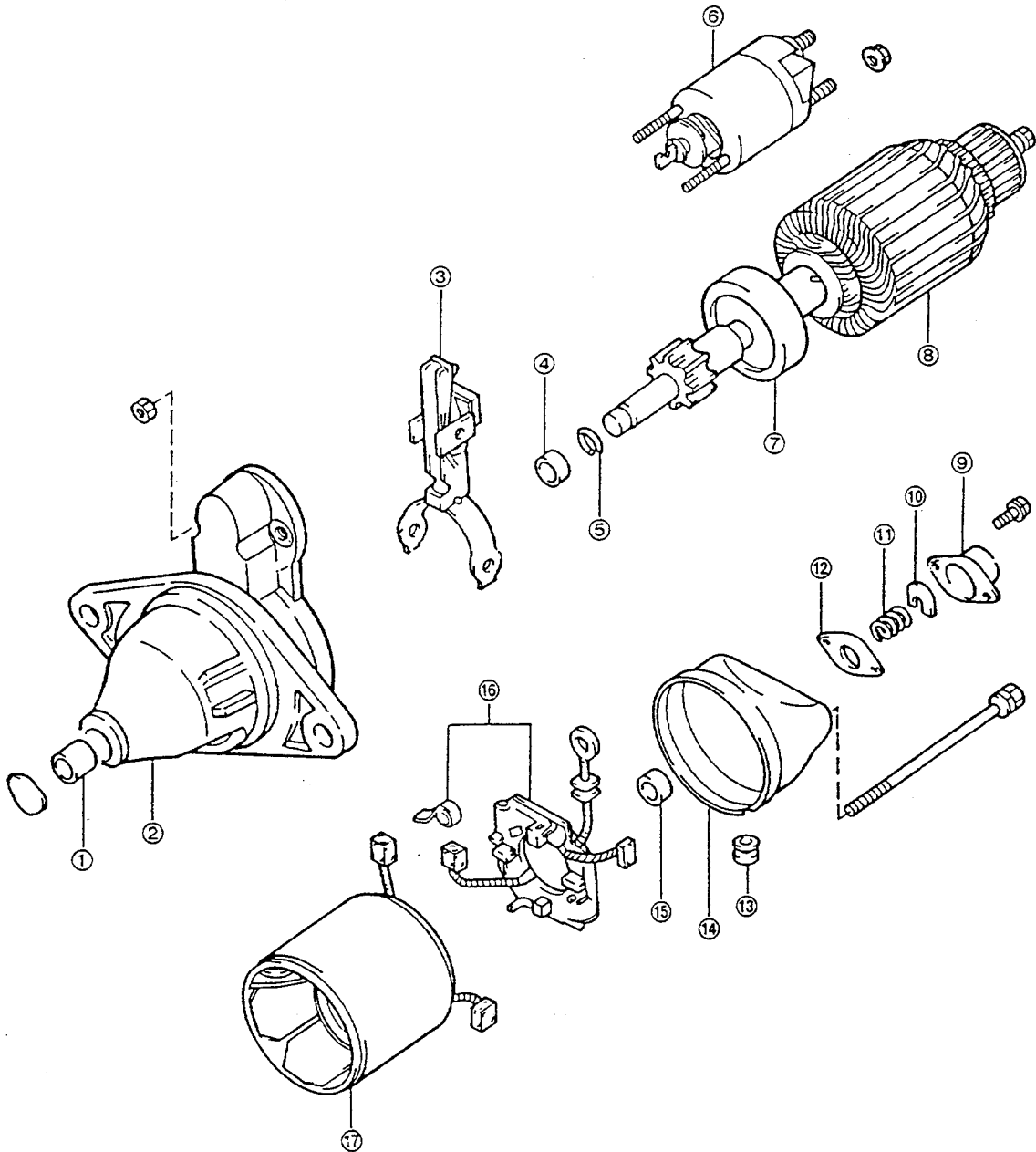

- ① Screw
- ② Starter drive housing
- ③ Starter pinion drive lever
- ④ Stop collar
- ⑤ Snap ring
- ⑥ Magnetic switch
- ⑦ Starter clutch
- ⑧ Armature
- ⑨ Bearing cover

- ⑩ Lock plate
- ⑪ Spring
- ⑫ Cover
- ⑬ Dust protector
- ⑭ Commutator end frame
- ⑮ Bush
- ⑯ Bush holder
- ⑰ Field frame

Fig. 10-29

[CB-23 Engine A/T & CB-80 Engine with ECE & EEC Specification]

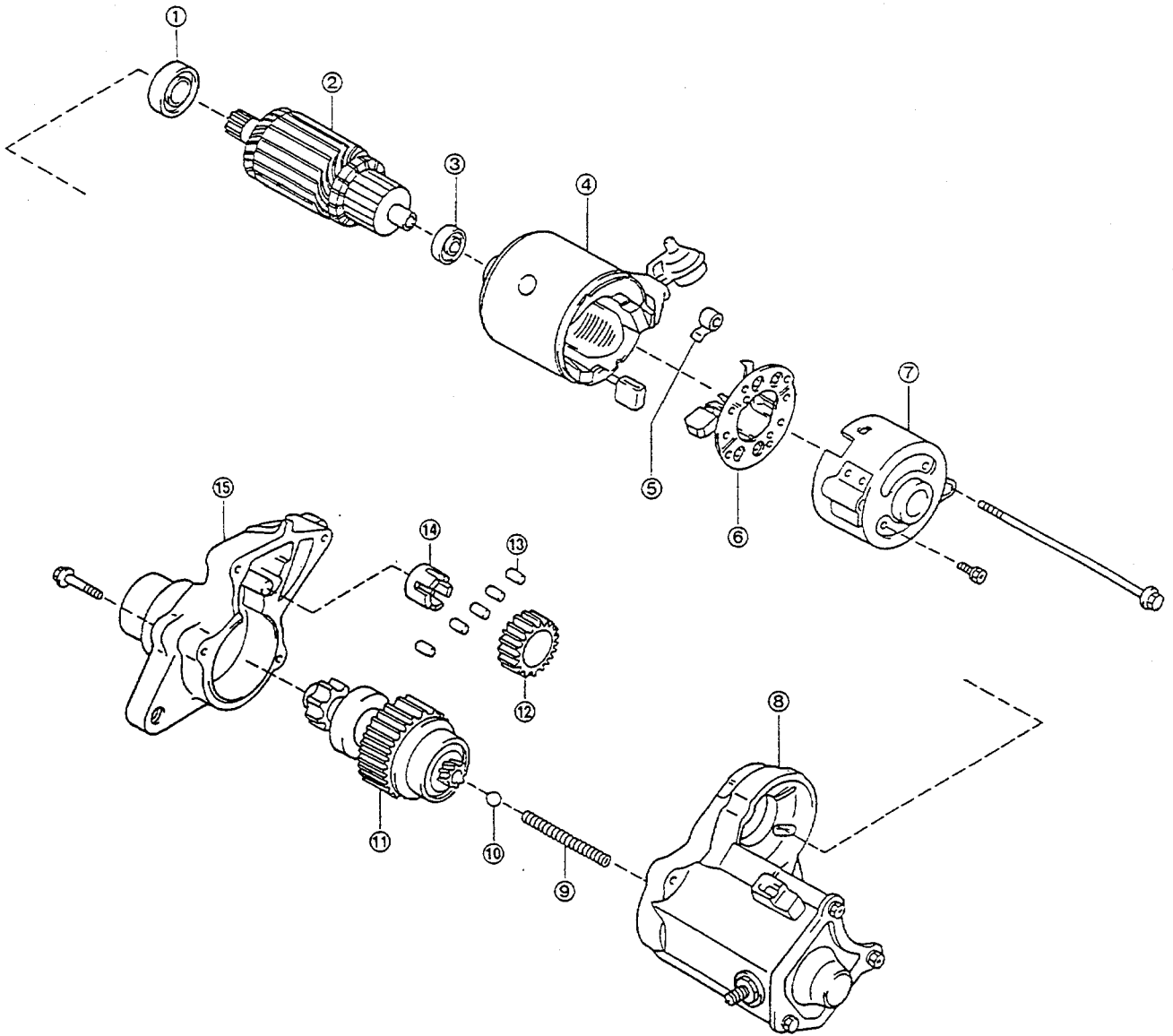

- | | |
|---------------------------|-------------------------|
| ① Bearing | ⑨ Spring |
| ② Armature | ⑩ Ball |
| ③ Bearing | ⑪ Starter clutch |
| ④ Starter yoke | ⑫ Idle gear |
| ⑤ Spring brush | ⑬ Roller |
| ⑥ Brush holder | ⑭ Retainer |
| ⑦ Drive housing | ⑮ Starter drive housing |
| ⑧ Magnetic starter switch | |

Fig. 10-30

WM-10035

ENGINE ELECTRICAL SYSTEM

PERFORMANCE TEST

CAUTION:

Each of the following tests must be performed within three to five seconds to avoid burning out the coil.

WM-10036

1. Perform the pull-in test.
 - (1) Disconnect the field coil lead from the terminal C.
 - (2) Connect the battery to the magnetic switch as shown in the right figure. Ensure that the pinion moves outward.
If the pinion does not move, replace the magnetic switch.

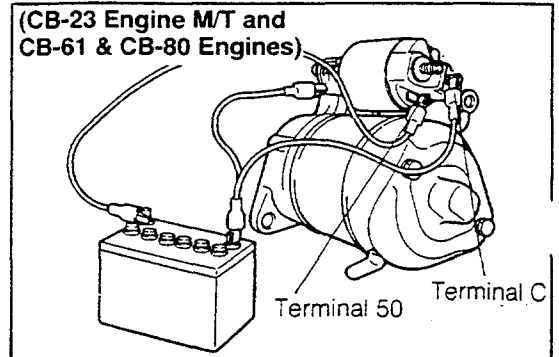

Fig. 10-31

WM-10037

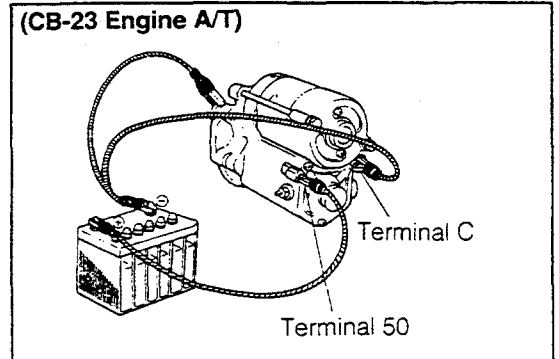

Fig. 10-32

WM-10038

2. Perform the hold-in test.

While still connected above and with the pinion out, disconnect the negative lead from the terminal C. Ensure that the pinion remains out. If the pinion returns inward, replace the magnetic switch.

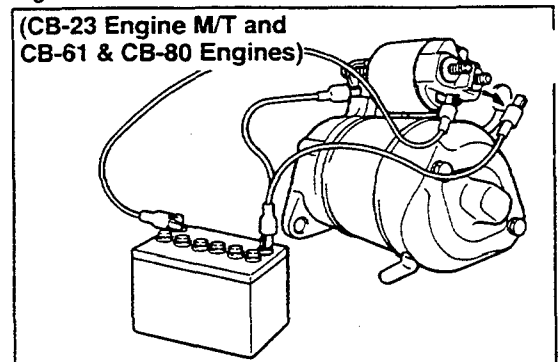

Fig. 10-33

WM-10039

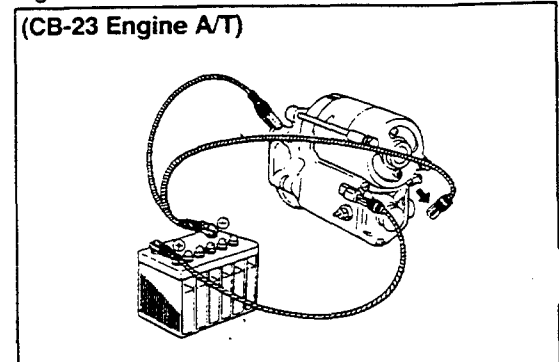

Fig. 10-34

WM-10040

Check the pinion return.
 Disconnect the negative lead from the switch body.
 Ensure that pinion returns inward. If the pinion does not return, replace the magnetic switch.

4. Perform the no-load performance (CB-23 Engine M/T and CB-61 & CB-80 Engines)
 - (1) Connect the field coil lead to the terminal C. Make sure that the lead is not grounded.
 - (2) Connect the battery and ammeter to the starter as shown in Fig. 10-40.
 - (3) Ensure that the starter rotates smoothly and steadily with the pinion moving out.
 - (4) Ensure that the ammeter registers the specified current.
 Specified Current: Less Than 50 A at 11 V
5. Perform the no-load performance (CB-23 Engine A/T)
 - (1) Connect the battery and ammeter to the starter as shown in the right figure.
 - (2) Ensure that the starter rotates smoothly and steadily with the pinion moving out.
 Ensure that the ammeter registers the specified current.
 Specified Current: Less Than 90 A at 11.5 V
6. Check the pinion clearance. (Except CB-23 Engine A/T)
 - (1) Connect the battery to the magnetic switch as shown in Fig. 10-42.

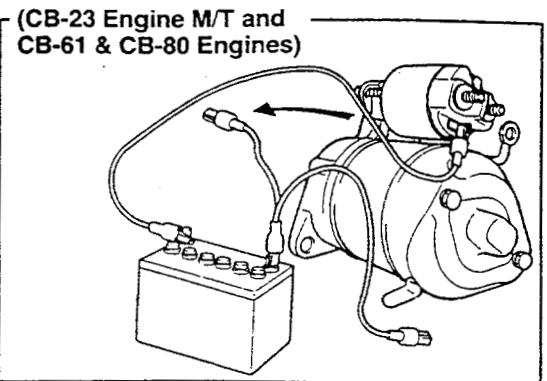

Fig. 10-35

WM-10041

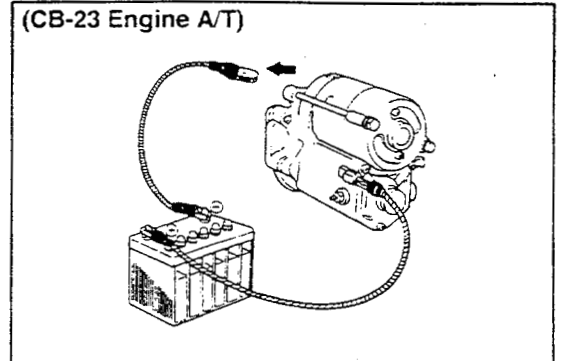

Fig. 10-36

WM-10042

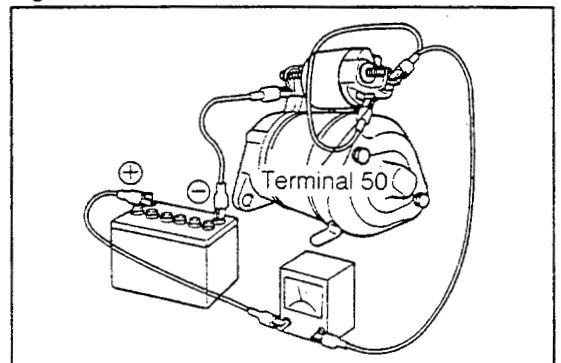

Fig. 10-37

WM-10043

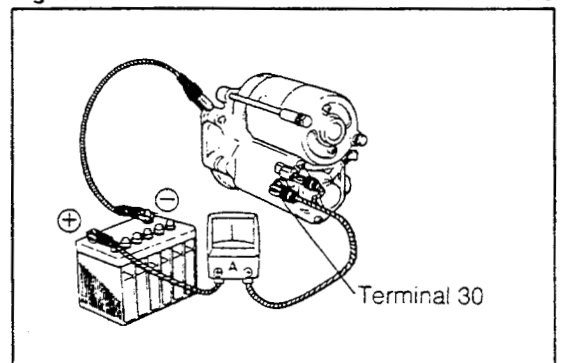

Fig. 10-38

WM-10044

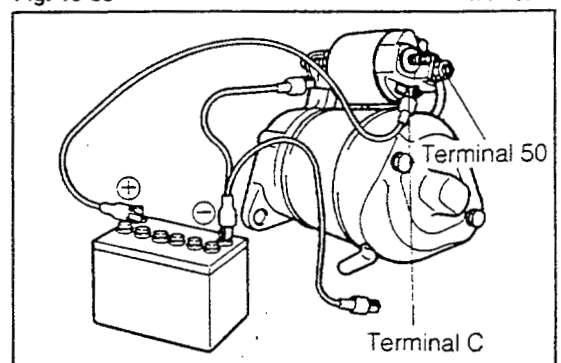

Fig. 10-39

WM-10045

ENGINE ELECTRICAL SYSTEM

- (2) Move the pinion gear toward the armature to remove any play. Measure the clearance between the pinion end and the stop collar.

Specified Clearance: 0.1 - 4.0 mm
(0.004 - 0.157 inch)

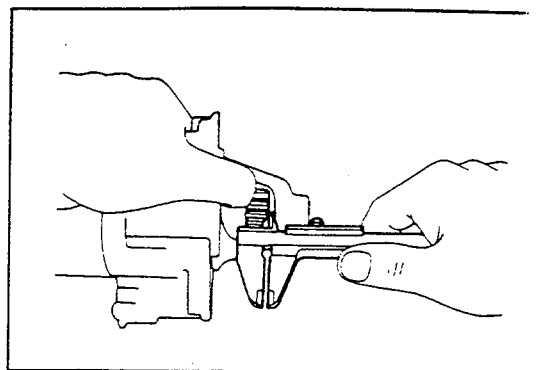

Fig. 10-40

WM-10046

DISASSEMBLY

[CB-23 Engine M/T and CB-61 & CB-80 Engines]

1. Remove the magnetic switch.
 - (1) Remove the nut. Disconnect the lead wire from the magnetic switch terminal.
 - (2) Loosen the two nuts holding the magnetic switch to the switch housing. Lift the magnetic switch up and out to unhook the plunger from the drive lever.

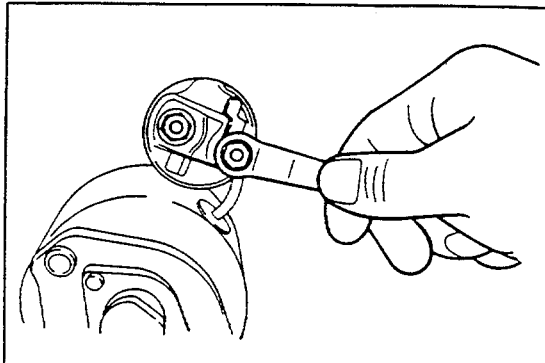

Fig. 10-41

WM-10047

2. Remove the end frame.
 - (1) Remove the bearing cover.
 - (2) Using a feeler gauge, check the armature shaft thrust clearance between the lock plate and the end frame.
Thrust clearance: 0.05 - 0.60 mm
(0.0020 - 0.0236 inch)

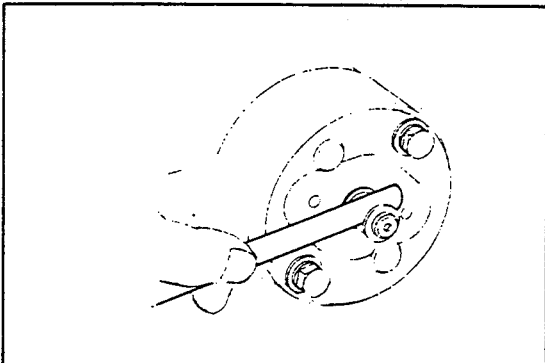

Fig. 10-42

WM-10048

- (3) Remove the lock plate, spring and rubber.
 - (4) Remove the two through bolts and pull out the commutator end frame.

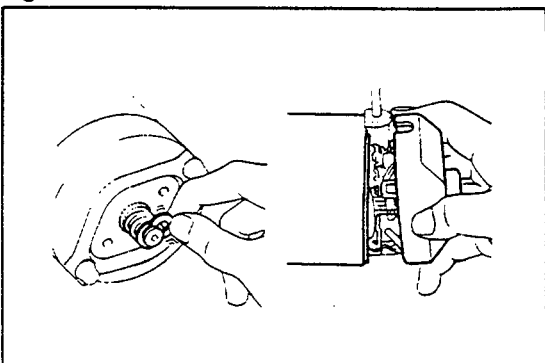

Fig. 10-43

WM-10049

3. Remove the brushes and brush holder.
 - (1) Using a piece of steel wire, separate the brush springs. Remove the brushes from the brush holder.
 - (2) Pull the brush holder off the armature.

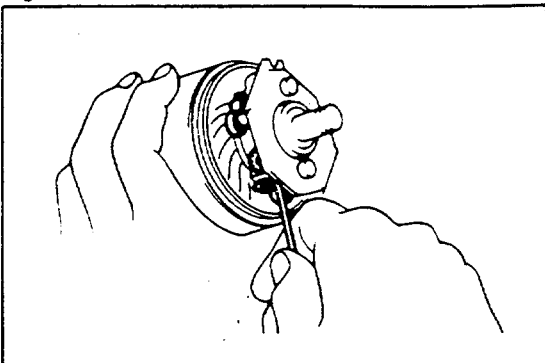

Fig. 10-44

WM-10050

Remove the field frame from the drive housing.
Pull them apart by hands.

5. Remove the armature.
 - (1) Remove the drive lever from the drive housing.
 - (2) Pull the armature from the drive housing.

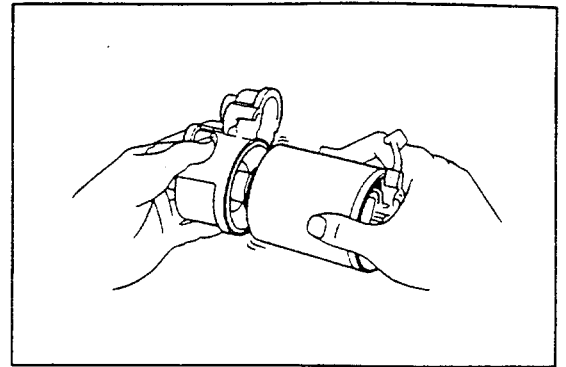

Fig. 10-45

WM-10051

6. Remove the starter clutch.
 - (1) Detach the stop collar, using a screwdriver.
 - (2) Pry off the snap ring, using a screwdriver.
 - (3) Remove the collar from the shaft.

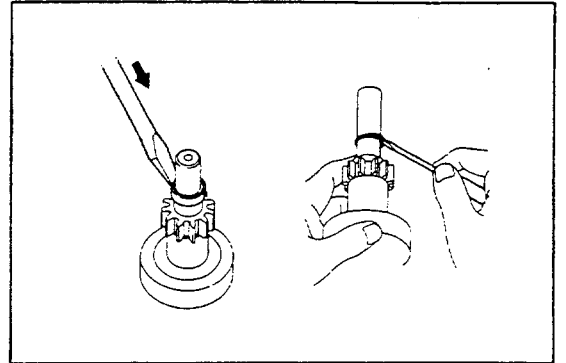

Fig. 10-46

WM-10052

- (4) If any difficult is encountered in pulling out the pinion, smoothen the shaft with an oil stone.
- (5) Remove the starter clutch.

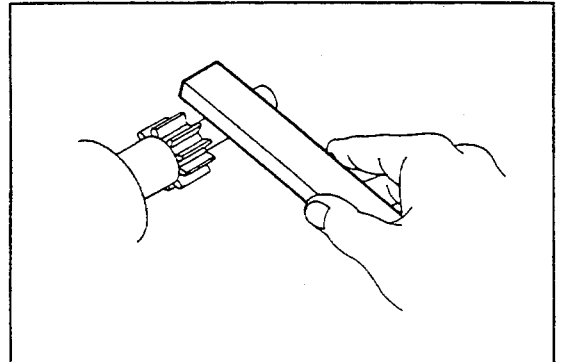

Fig. 10-47

WM-10053

DISASSEMBLY [CB-23 Engine A/T]

Remove the field frame with armature from the magnetic switch.

- (1) Disconnect the lead wire from the magnetic switch terminal.
- (2) Remove the two through bolts. Pull out the field frame with the armature from the magnetic switch.
- (3) Remove the left seal.

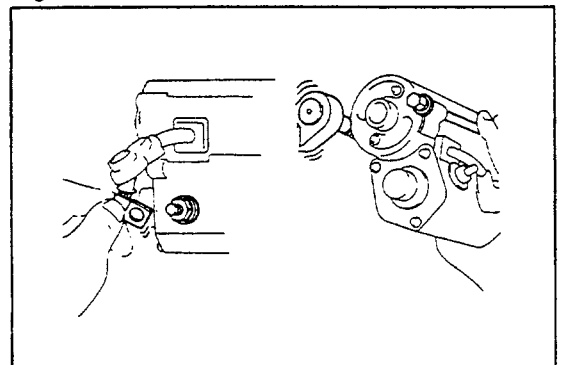

Fig. 10-48

WM-10054

2. Remove the starter housing from the magnetic switch assembly.
Remove the two screws and remove the starter housing with the idler gear and clutch assembly.

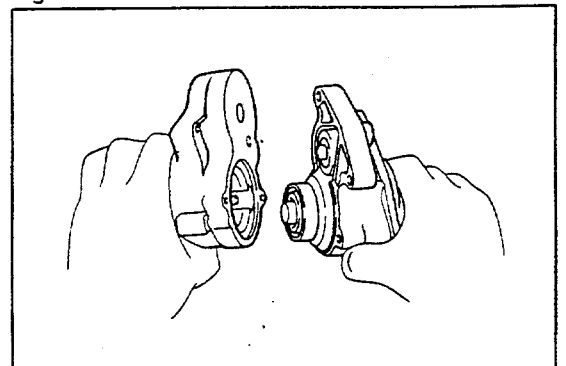

Fig. 10-49

WM-10055

ENGINE ELECTRICAL SYSTEM

3. Remove the clutch assembly and idler gear from the starter housing.
4. Remove the steel ball and spring. Using a magnetic finger, remove the spring and steel ball from the clutch shaft hole.

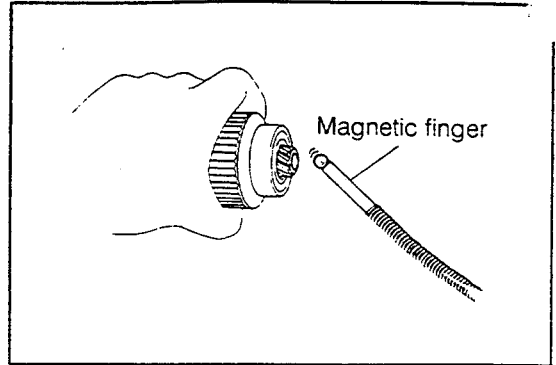

Fig. 10-50

WM-10056

5. Remove the brushes and brush holder.
 - (1) Remove the endcover from the field frame.
 - (2) Separate the brush springs, using a screwdriver or a steel wire. Remove the brushes from the brush holder.
 - (3) Pull the brush holder off the field frame.
6. Remove the armature from the field frame.

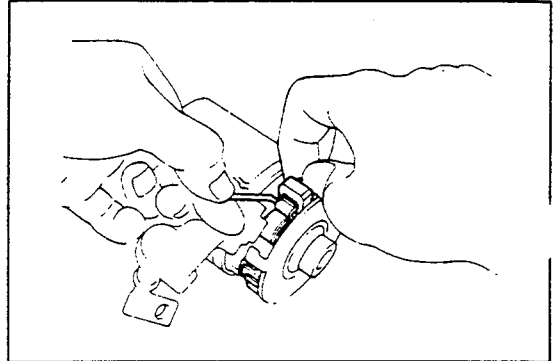

Fig. 10-51

WM-10057

INSPECTION

Armature Coil

1. Ensure that the commutator is not grounded. Using an ohmmeter, ensure that no continuity exists between the commutator and the armature coil core. If continuity exists, replace the armature.
2. Check the commutator for open circuit. Using an ohmmeter, ensure that continuity exists between the segments of the commutator. If no continuity exists between any segments, replace the armature.

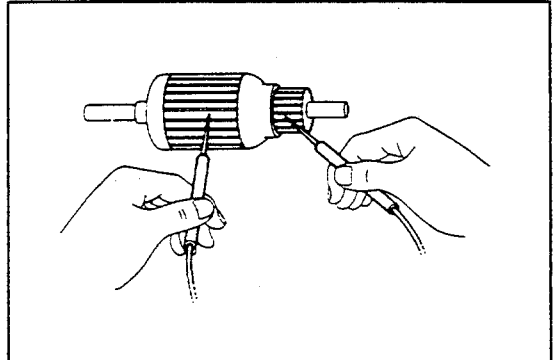

Fig. 10-52

WM-10058

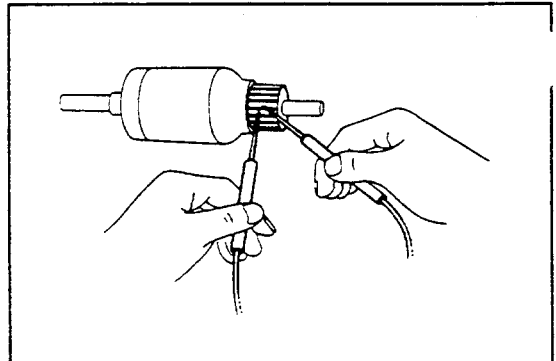

Fig. 10-53

WM-10059

Field Coil

1. Check the field coil for open circuit. Using an ohmmeter, ensure that continuity exists between the lead wire and the field coil brush lead. If no continuity exists, replace the field coil.

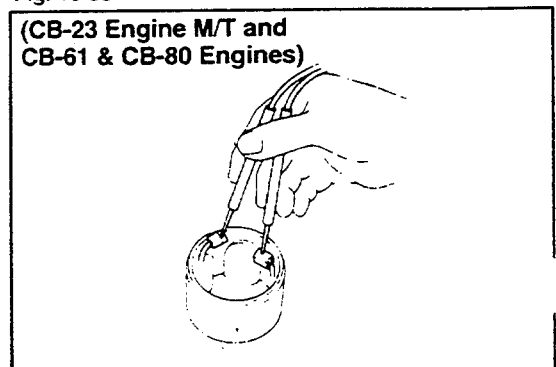

Fig. 10-54

WM-10060

2. Ensure that the field coil is not grounded. Using an ohmmeter, ensure that no continuity exists between the field coil end and the field frame. If continuity exists, replace the field coil.

Brush Holder

1. Check the brush holder for insulation. Using an ohmmeter, ensure that no continuity exists between the positive and negative brush holders. If continuity exists, repair or replace the brush holder.

Starter Clutch

1. Inspect the pinion gear and spline teeth. Inspect the pinion gear and spline teeth for wear or damage. If damaged, replace the starter clutch. Also, inspect the flywheel ring gear for wear or damage.
2. Check the clutch. Rotate the pinion clockwise. Ensure that the pinion is locked. Then, rotate the pinion counterclockwise. Ensure that the pinion rotates freely.

Bearings

1. Inspect the bearings. Turn each bearing by hands while applying a force to the bearing. If any resistance or binding is felt, replace the bearing.

(CB-23 Engine A/T)

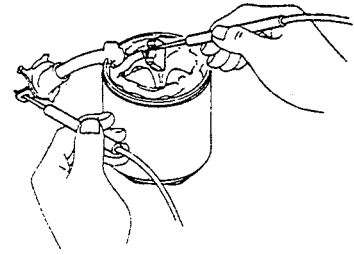

Fig. 10-55

WM-10061

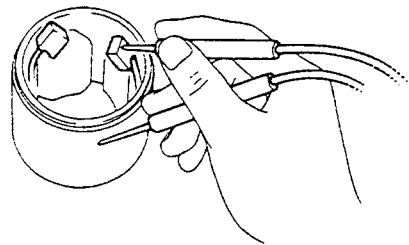

Fig. 10-56

WM-10062

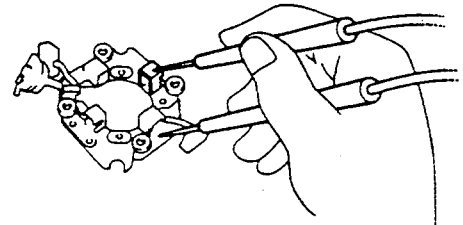

Fig. 10-57

WM-10063

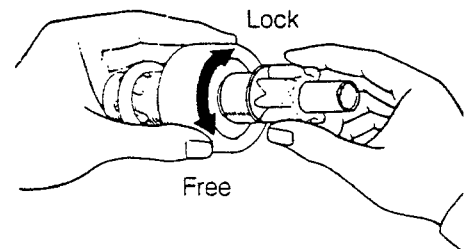

Fig. 10-58

WM-10064

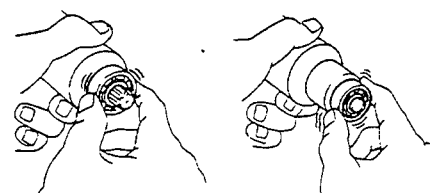

Fig. 10-59

WM-10065

ENGINE ELECTRICAL SYSTEM

2. Replace the bearings, as required.
 - (1) Remove the bearing from the armature shaft, using the following SST.
 - (2) Remove the other bearing from the opposite side.
SST: 09286-46011
 - (3) Tape the front bearing onto the shaft, using the following SST.
SST: 09285-76010
 - (4) Install the rear bearing onto the shaft, using a press.

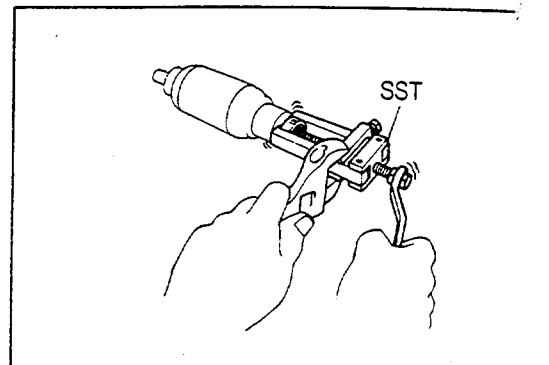

Fig. 10-60

WM-10066

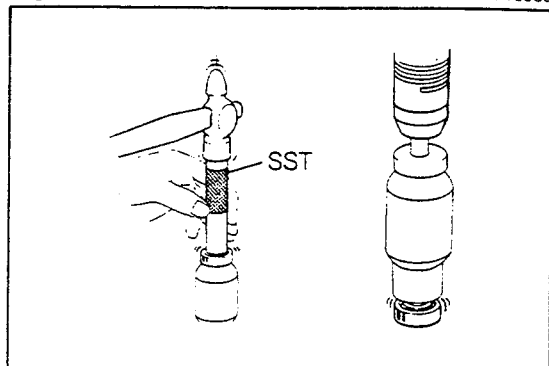

Fig. 10-61

WM-10067

Magnetic Switch

[CB-23 Engine M/T and CB-61 & CB-80 Engines]

1. Check the plunger.

Push in the plunger and release it. Ensure that it returns quickly to its original position.
2. Perform the pull-in coil open circuit test.

Using an ohmmeter, ensure that continuity exists between the terminal 50 and the terminal C.
If no continuity exists, replace the magnetic switch.
3. Perform the hold-in coil open circuit test.

Using an ohmmeter, ensure that continuity exists between the terminal 50 and the switch body.
If no continuity exists, replace the magnetic switch.

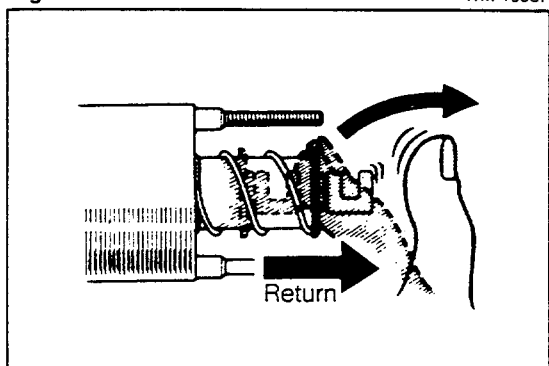

Fig. 10-62

WM-10068

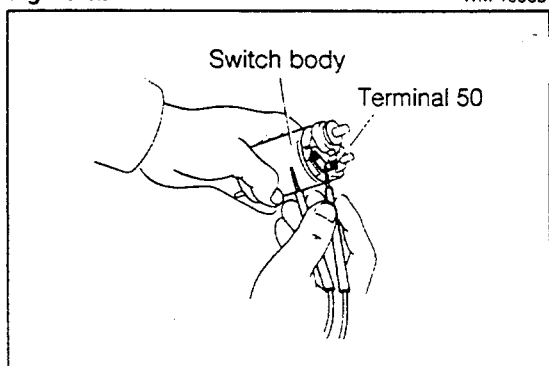

Fig. 10-63

WM-10069

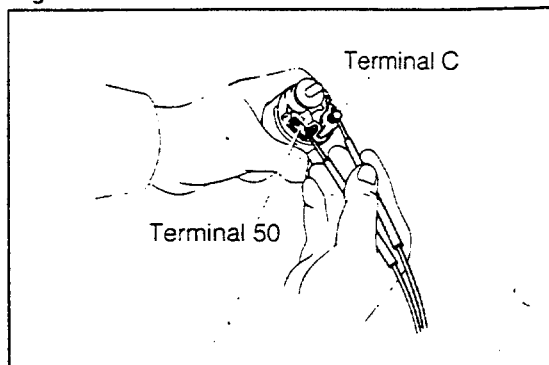

Fig. 10-64

WM-10070

Magnetic Switch [CB-23 Engine A/T]

1. Perform the pull-in coil open circuit test.
Using an ohmmeter, ensure that continuity exists between the terminal 50 and the terminal C.
If no continuity exists, replace the magnetic switch.

2. Perform the hold-in coil open circuit test.
Using an ohmmeter, ensure that continuity exists between the terminal 50 and the switch body.
If no continuity exists, replace the magnetic switch.

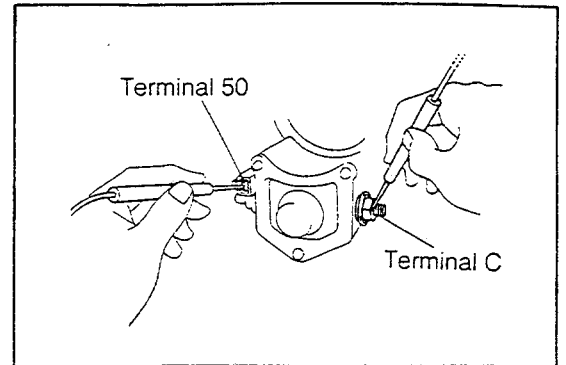

Fig. 10-65

WM-10071

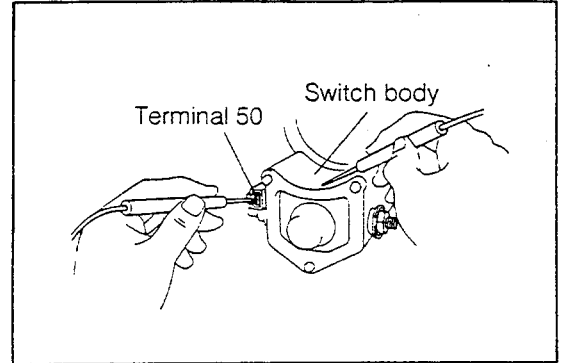

Fig. 10-66

WM-10072

ASSEMBLY [CB-23 Engine M/T and CB-61 & CB-80 Engines]

NOTE:

Use high-temperature grease to lubricate the bearings and sliding parts when assembling the starter.

WM-10073

1. Assemble the starter clutch to the armature.
 - (1) Place a new stop collar on the armature.
 - (2) Drive in the snap ring with a 14 mm (0.5 inch) socket wrench or the like. Then, fit it into the shaft groove.

- (3) Using a vise, compress the snap ring. Make sure that the snap ring fits correctly.

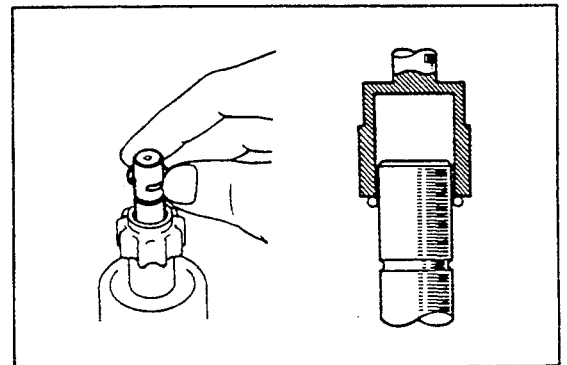

Fig. 10-67

WM-10074

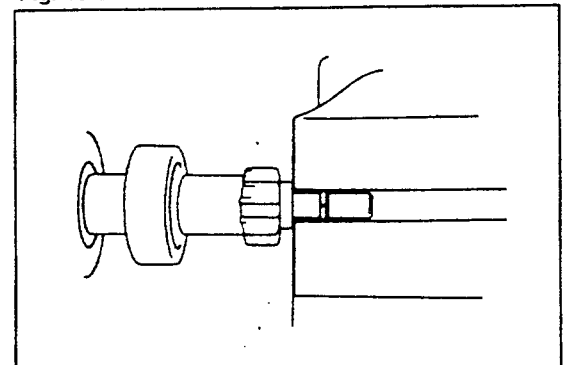

Fig. 10-68

WM-10075

ENGINE ELECTRICAL SYSTEM

- (4) Using a screwdriver, tap the pinion to slide the stop collar onto the snap ring.
-
2. Assemble the drive housing, drive lever and field frame to the armature.
 - (1) Apply grease to the drive lever and drive housing bushing.
 - (2) Install the drive lever to the drive housing.
 - (3) Install the field frame on the armature.

 3. Install the brush holder and brushes.
 - (1) Place the brush holder over the armature shaft.
 - (2) Using a piece of steel wire, hold the brush spring back and install the brush in the brush holder. Install the four brushes.

 4. Install the end frame.
 - (1) Apply grease to the end frame bushing.
 - (2) Install the end frame on the armature shaft and secure with two through bolts.

 5. Install the bearing cover.
 - (1) Install the rubber, spring and lock plate.
 - (2) Using a feeler gauge, measure the armature thrust clearance between the lock plate and the end frame.
Thrust clearance: 0.05 - 0.60 mm
(0.0020 - 0.0236 inch)
 - (3) Install the bearing cover with the two screws.

 6. Install the magnetic switch.

Hook the magnetic switch stud underneath the drive lever spring. Install the two nuts.

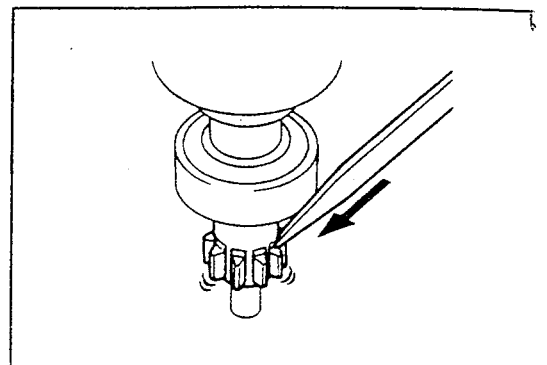

Fig. 10-69

WM-10076

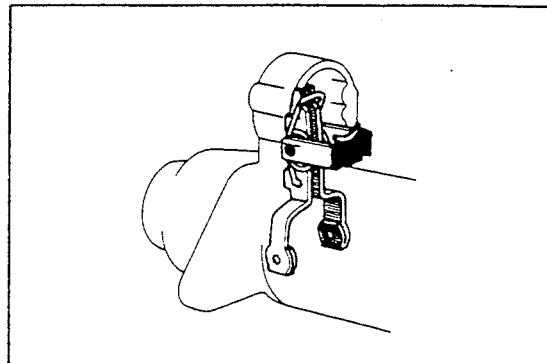

Fig. 10-70

WM-10077

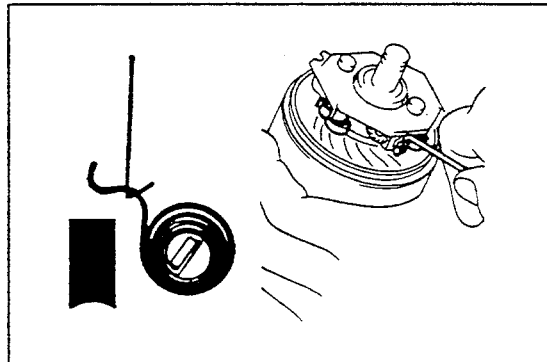

Fig. 10-71

WM-10078

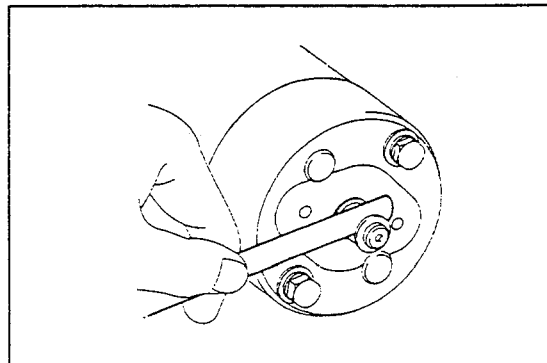

Fig. 10-72

WM-10079

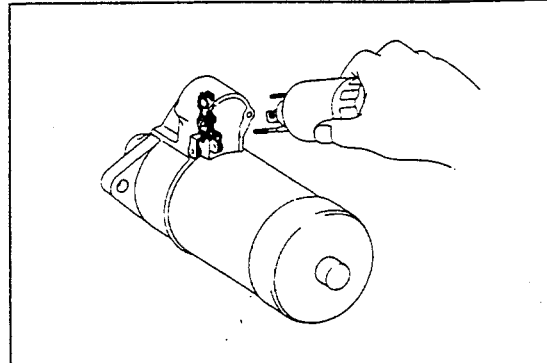

Fig. 10-73

WM-10080

ASSEMBLY [CB-23 Engine A/T]

NOTE:

Use high-temperature type grease to lubricate the bearings and gears when assembling the starter.

1. Place the armature into the field frame.
Apply grease to the armature bearings and insert the armature into the field frame.

WM-10081

2. Install the brush holder and brushes.
 - (1) While the brush spring is held back by means of a screwdriver, install the brush into the brush holder. Thus, install the four brushes.

NOTE:

Make sure that the positive lead wires are not grounded.

- (2) Install the end cover to the field frame.
3. Install the steel ball into the clutch shaft hole.
Apply grease to the ball and spring, and insert them into the clutch shaft hole.

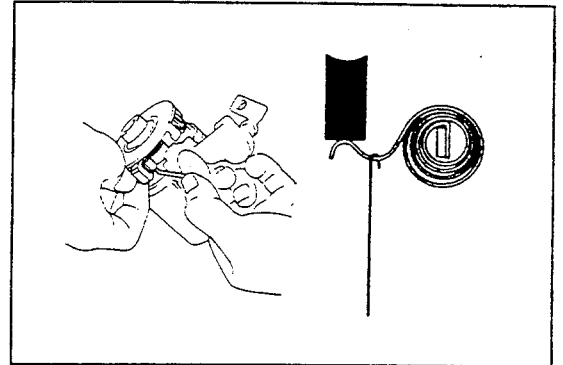

Fig. 10-74

WM-10082

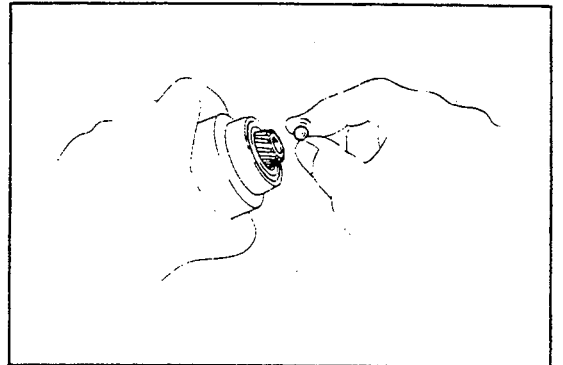

Fig. 10-75

WM-10083

4. Install the gear and clutch assembly.
 - (1) Apply grease to the gear and clutch assembly.
 - (2) Place the clutch assembly, idle gear and bearing in the starter housing.

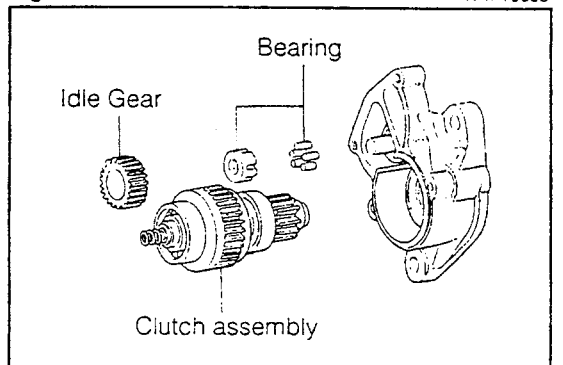

Fig. 10-76

WM-10084

5. Install the starter housing.
Place the starter housing on the magnetic switch and install the two screws.

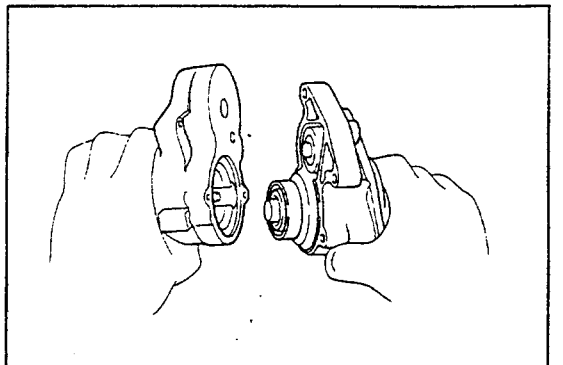

Fig. 10-77

WM-10085

ENGINE ELECTRICAL SYSTEM

6. Install the field frame with armature in the magnetic switch.
 - (1) Place the felt seal on the armature shaft.
 - (2) Align the protrusion of the field frame with the magnetic switch.

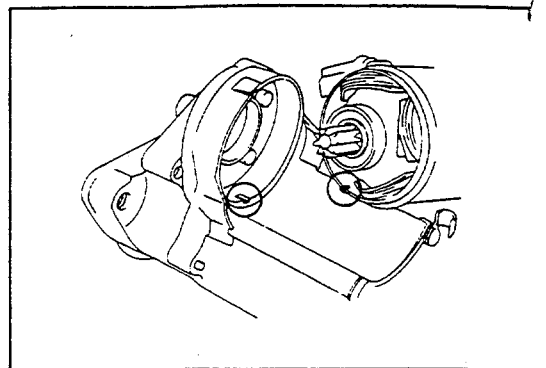

Fig. 10-78

WM-10086

- (3) Install the two through bolts.
 - (4) Connect the coil lead to the terminal on the magnetic switch.

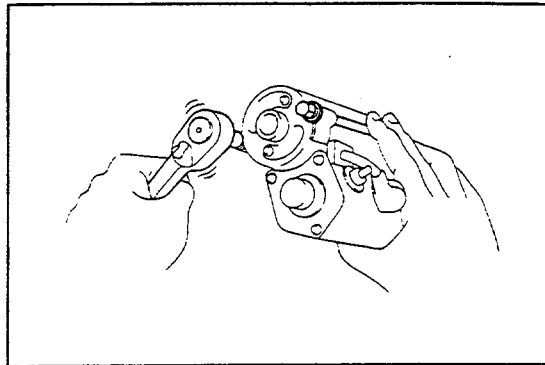
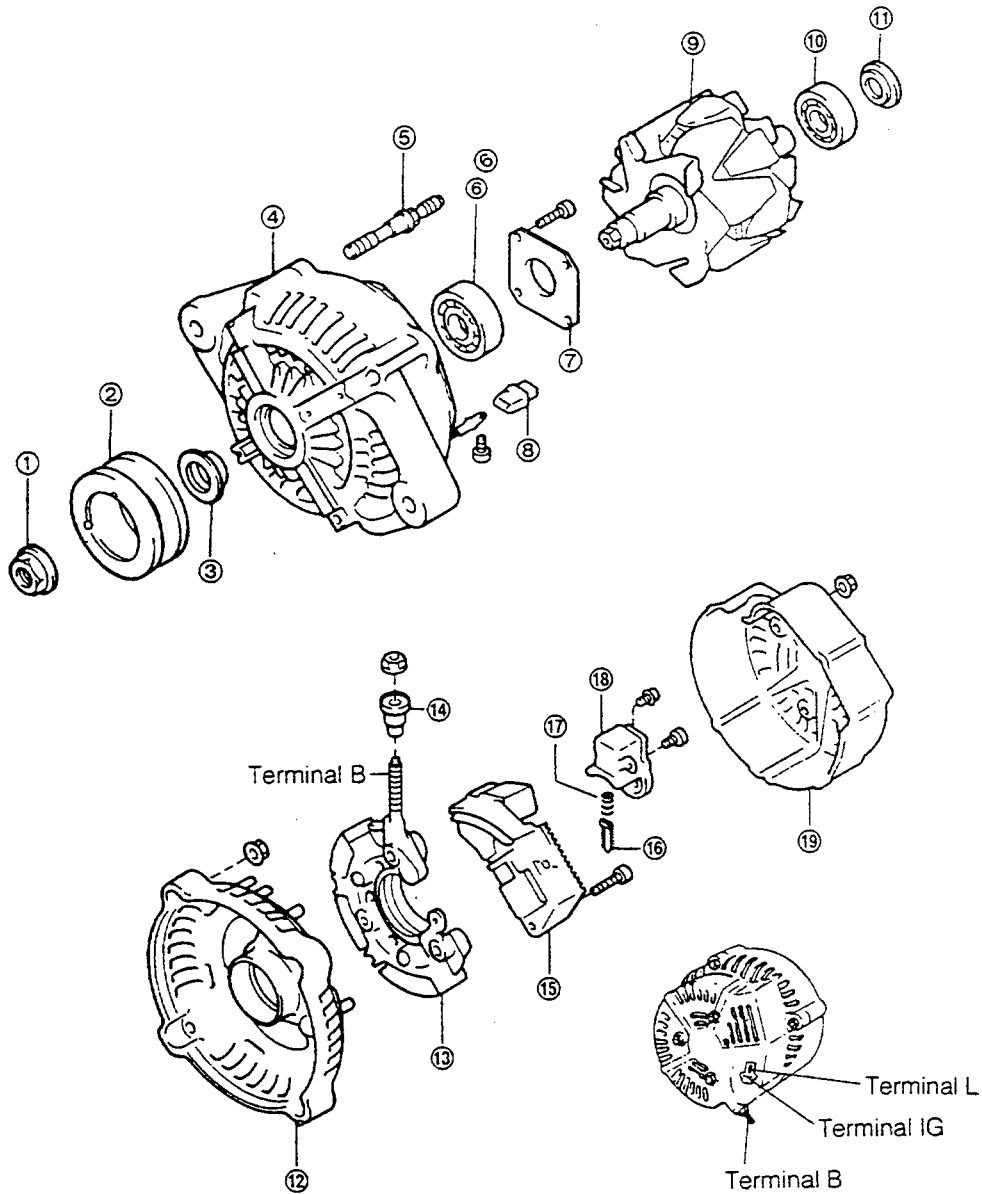

Fig. 10-79

WM-10087

ALTERNATOR
COMPONENTS OF ALTERNATOR



- ① Pulley lock nut
- ② Alternator pulley
- ③ Spacer collar
- ④ Drive end frame Ay
- ⑤ Stud bolt
- ⑥ Bearing
- ⑦ Retainer plate
- ⑧ Bush
- ⑨ Alternator rotor Ay
- ⑩ Bearing

- ⑪ Bearing cover
- ⑫ Rear end frame
- ⑬ Rectifier
- ⑭ Terminal insulator
- ⑮ IC regulator
- ⑯ Brush
- ⑰ Spring
- ⑱ Brush holder Ay
- ⑲ Rear end cover

Fig. 10-80

ENGINE ELECTRICAL SYSTEM

DISASSEMBLY

1. Remove the nut and terminal B insulator.

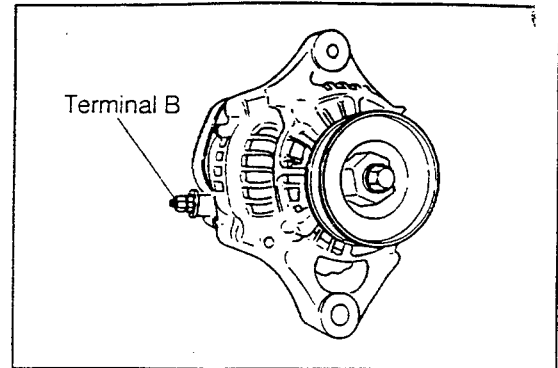

Fig. 10-81

WM-10089

2. Remove the three bolts and rear end cover.

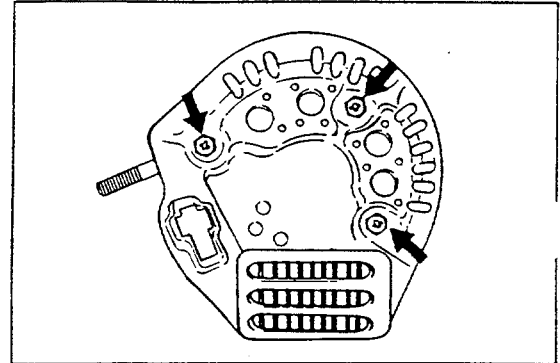

Fig. 10-82

WM-10090

3. Remove the two screws of the brush holder assembly. Also, remove the three screws of the IC regulator assembly.

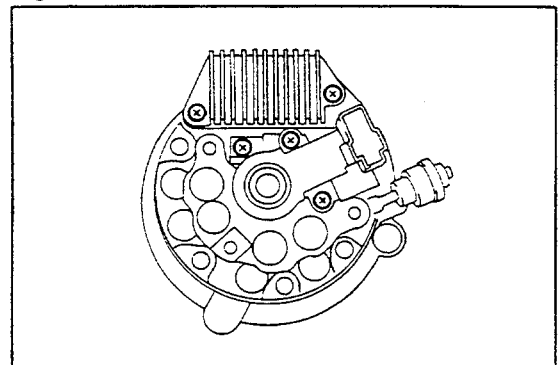

Fig. 10-83

WM-10091

4. Remove the brush holder assembly and regulator assembly.

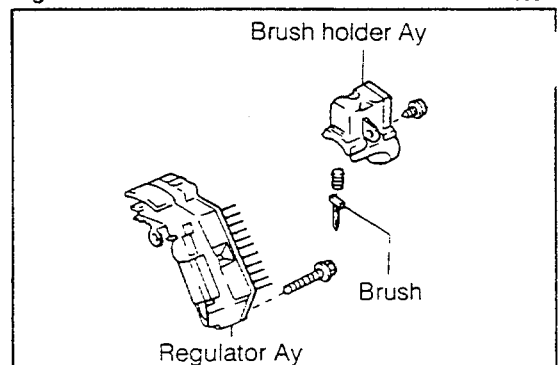

Fig. 10-84

WM-10092

INSPECTION

1. IC Regulator Diode

Ensure that continuity exists between the terminal B and the terminal F.

F → B Continuity exists.

B → F No continuity exists.

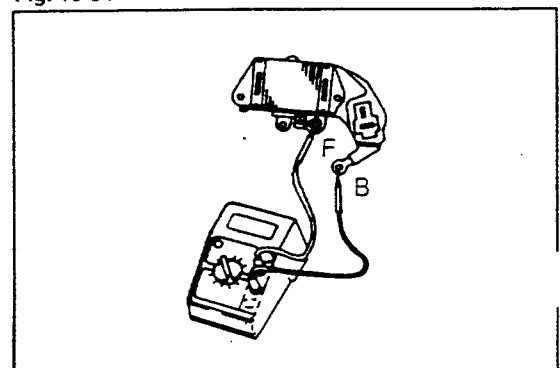

Fig. 10-85

WM-10093

Brush

Measure the exposed brush length.

Exposed length

Specified value: 10.5 mm (0.413 inch)

Limit: 4.5 mm (0.177 inch)

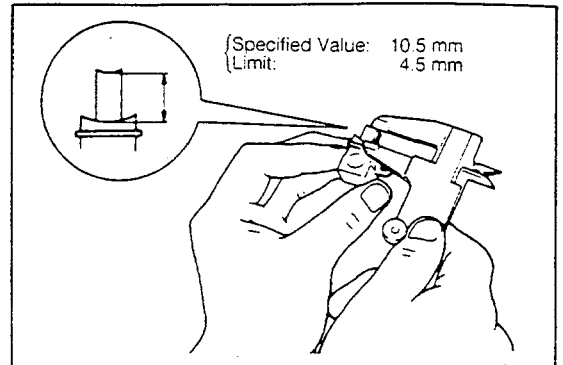

Fig. 10-86

WM-10094

3. Rectifier

Ensure that continuity exists between the terminal B and the rectifier terminal.

F → Rectifier Continuity exists.

Rectifier → B No continuity exists.

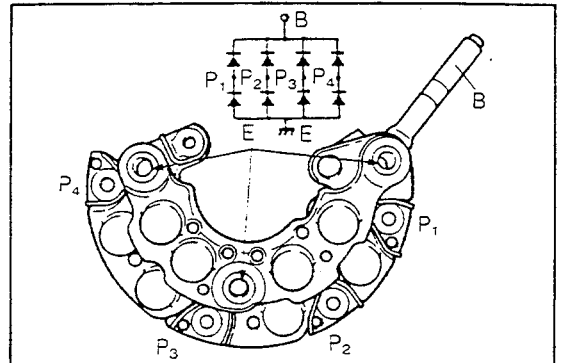

Fig. 10-87

WM-10095

4. Stator

Measure the resistance between the terminals, using an ohmmeter.

Resistance: Less than 1 Ω

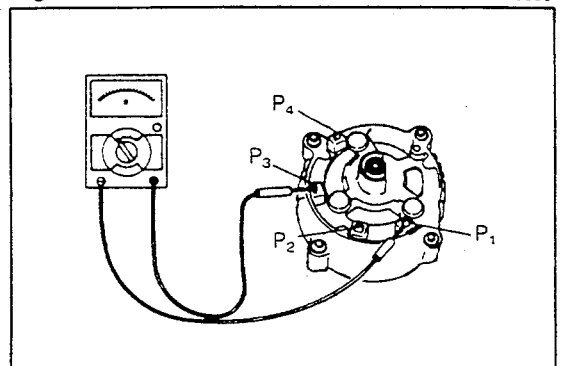

Fig. 10-88

WM-10096

5. Rotor

Measure the resistance between the slip rings, using an ohmmeter.

Resistance: 2.9 Ω

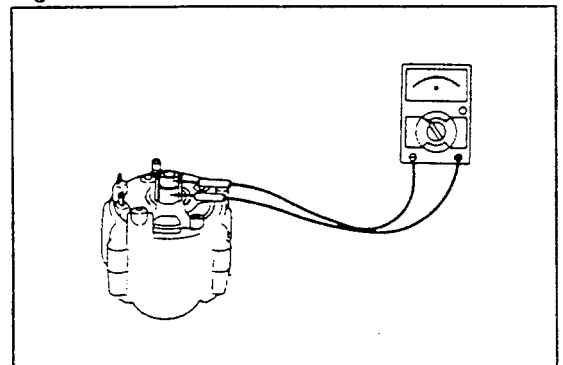

Fig. 10-89

WM-10097

ASSEMBLY

1. Install the brush holder assembly together with the IC regulator into the body from the side direction.

NOTE:

Be very careful not to distort the holder cover during the installation.

Install the brush holder, using the five screws. Also, install the IC regulator into position.

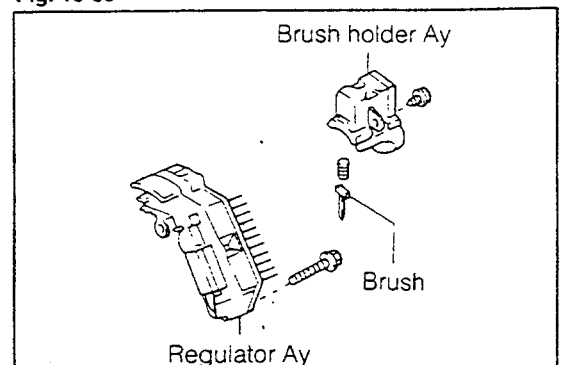

Fig. 10-90

WM-10098

ENGINE ELECTRICAL SYSTEM

3. Install the rear end cover.

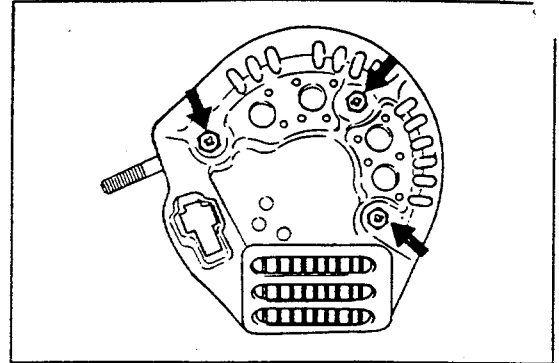

Fig. 10-91 WM-10099

4. Install the terminal B insulator and nut.

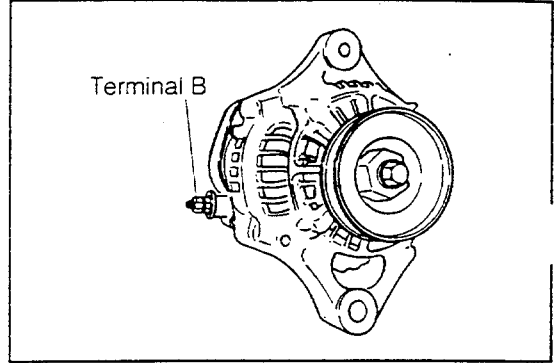

Fig. 10-92 WM-10100

IN-VEHICLE INSPECTION

1. No-Load Performance Test

- (1) Connect the probes to the battery. Connect the DC 200 A probe to the alternator terminal B wire harness.
- (2) Run the engine at 2000 rpm.
Regulating Voltage: 13.9 - 15.1 (25°C)
Current: Less than 10 A

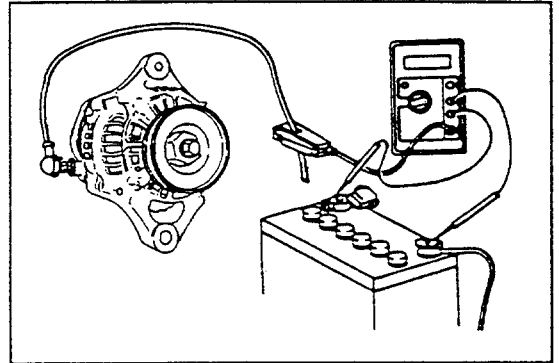

Fig. 10-93 WM-10101

2. Load Performance Test

- (1) Run the engine at 2000 rpm.
- (2) Turn on the headlamps and blower fan.
Regulated Voltage: 13.9 - 15.1 V
Current: More than 30 A

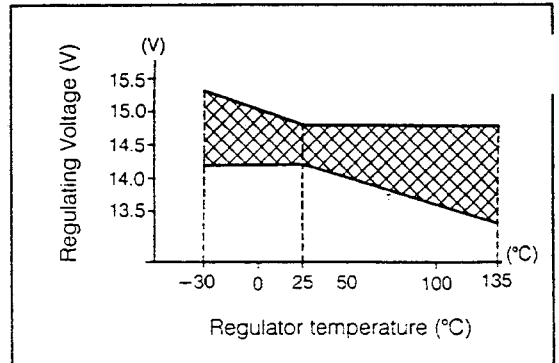

Fig. 10-94 WM-10102

DAIHATSU
TYPE CB
ENGINE

[CB-23, CB-61 & CB-80]

SECTION 11
INTAKE SYSTEM

AIR CLEANER	11-2
SURGE TANK [CB-61 Engine]	11-6
INTERCOOLER [CB-80 Engine]	11-7

WM-11001

INTAKE SYSTEM

AIR CLEANER

COMPONENTS OF AIR CLEANER [CB-23 Engine]

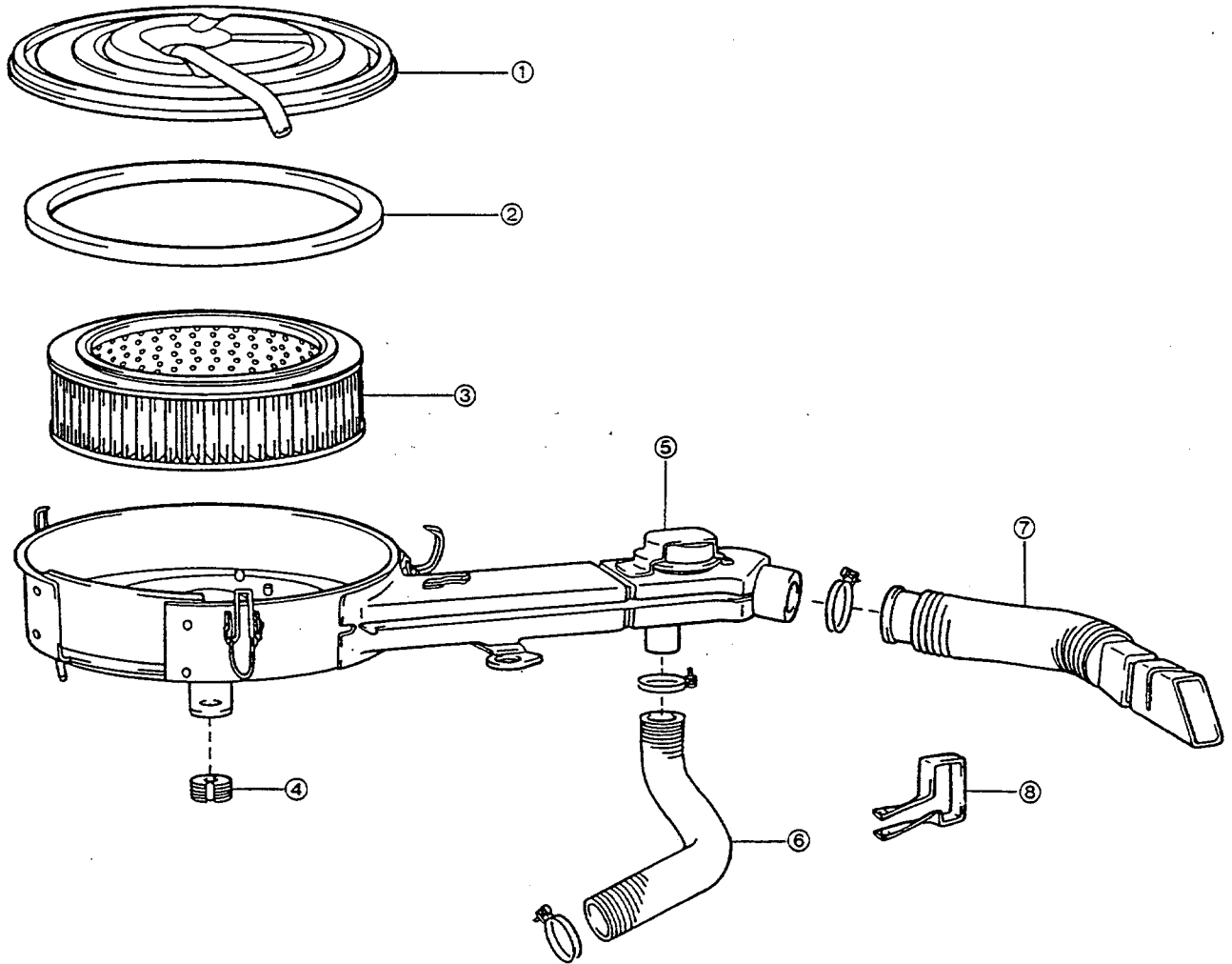

- ① Air cleaner cap
- ② Gasket
- ③ Air cleaner filter element
- ④ Grommet
- ⑤ Air cleaner case
- ⑥ Hot air intake duct
- ⑦ Air cleaner hose No.1
- ⑧ Clamp

Fig. 11-1

WM-11002

[CB-61 & CB-80 Engines]

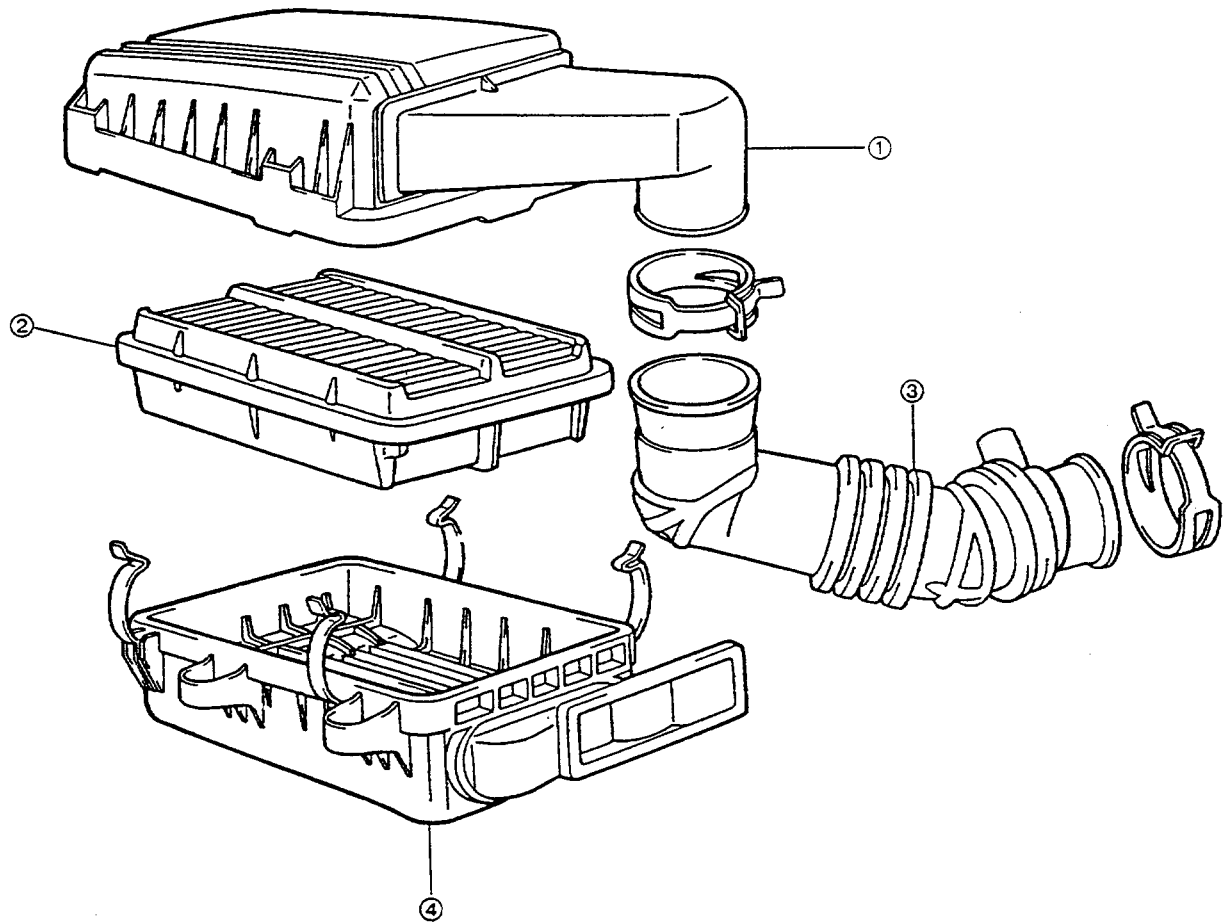

- ① Air cleaner cap
- ② Air cleaner filter element
- ③ Air cleaner hose No. 1
- ④ Air cleaner case

Fig. 11-2

WM-11003

INTAKE SYSTEM

INSPECTION

1. Check the air cleaner cap and case for deformation or damage. Replace or repair any defective parts.
2. Check the air cleaner element. If it is excessively dirty, clogged or damaged, clean or replace the element.
Element cleaning intervals: 10,000 km (6,000 mile)
Element replacement intervals:
40,000 km (24,000 mile)

NOTE:

If the vehicle is operated in dusty area, the cleaning or replacement of the element must be made at earlier time than the intervals above.

Cool Air/Hot Air Switching Adjustment System Check [CB-23 Engine]

1. Check the vacuum motor.
Ensure that the air control valve opens fully when a negative pressure of -180 mmHg is applied by means of a MityVac.
If the air control valve is malfunctioning, replace the air cleaner case.
2. Check the hoses and connections.
Visually inspect the hoses and connections for cracks, leakage or damage.

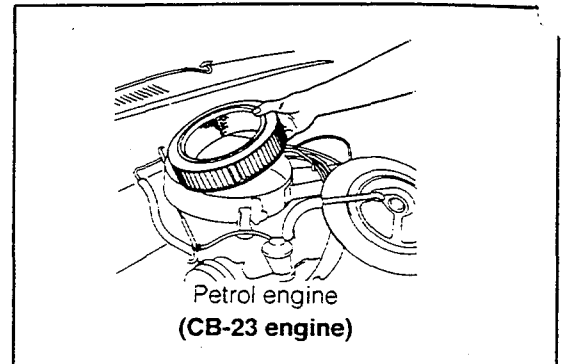

Fig. 11-3

WM-11004

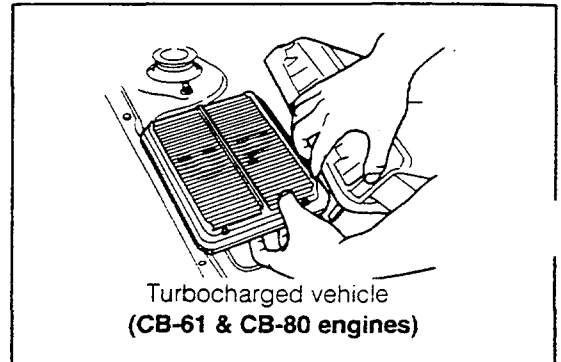

Fig. 11-4

WM-11005

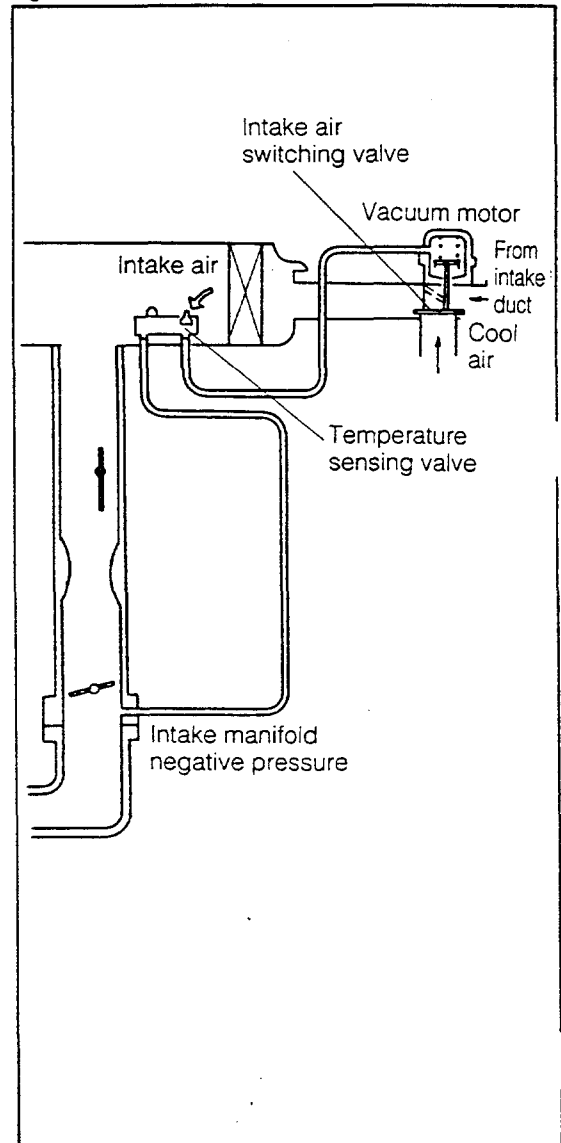

Fig. 11-5

WM-11006

Checking of operation of temperature sensing valve

- (1) Detach the air cleaner cap.
- (2) Cool the temperature sensing valve by cold air.
- (3) Ensure that the air control valve opens fully under this setting.

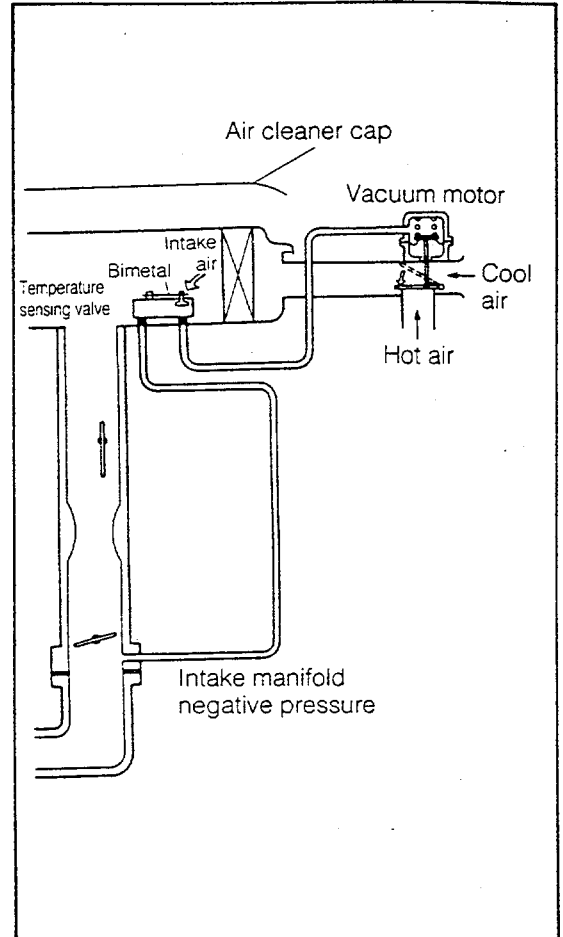

Fig. 11-6

WM-11007

- (4) Install the air cleaner cap.
 - (5) Start the engine. Run the engine at the idling speed.
 - (6) When the temperature inside the air cleaner case rises above about 30°C, ensure that the air control valve is opened fully.
- If the air control valve fails to open fully despite the temperature rise, replace the air cleaner case.

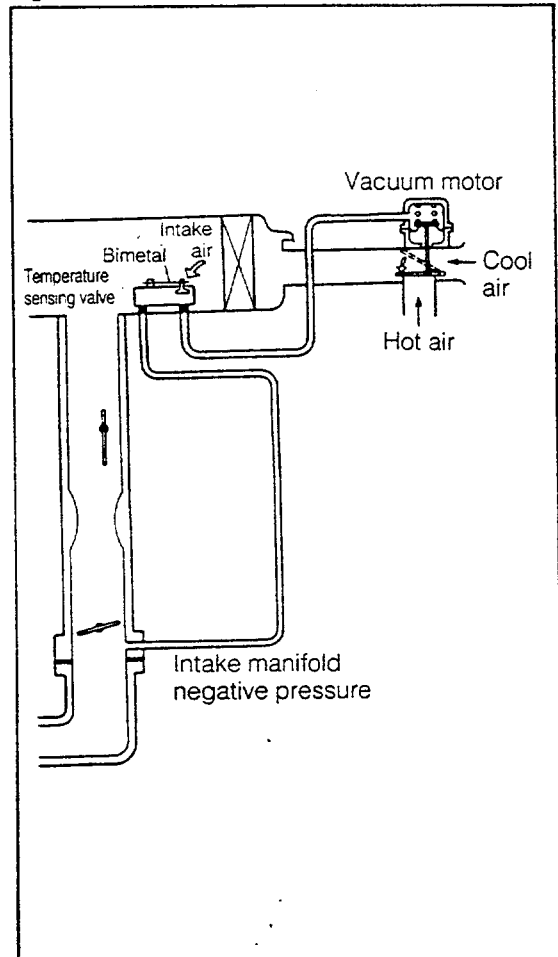

Fig. 11-7

WM-11008

INTAKE SYSTEM

SURGE TANK

COMPONENTS OF SURGE TANK [CB-61 Engine]

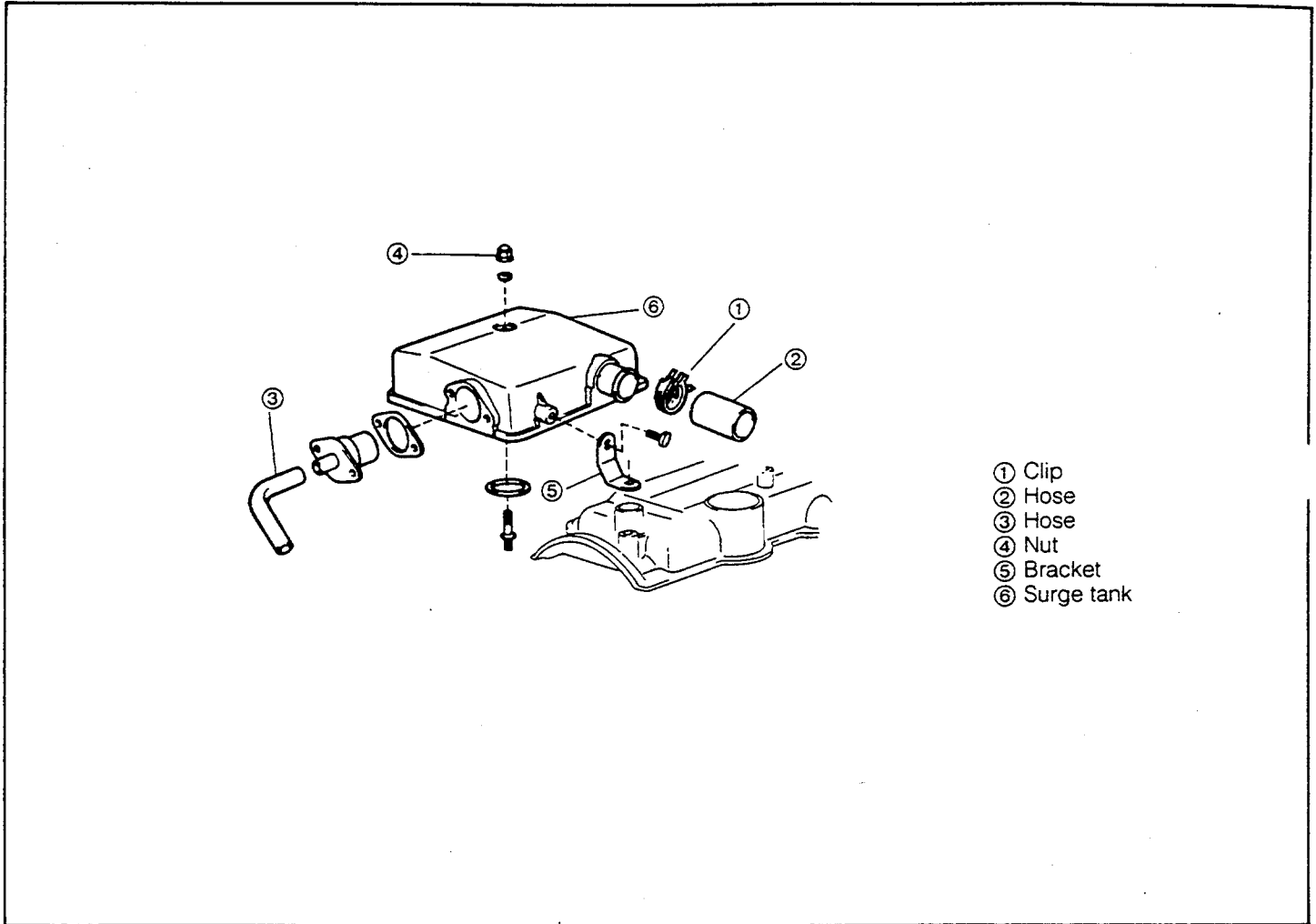

Fig. 11-8

WM-11009

INSPECTION

1. Check to see if the surge tank exhibits any sign of cracks or damage.
2. Disconnect the relief valve hose and blow your breath into the surge tank. There should be no air continuity.

3. Turbocharger Indicator Lamp

Inspection

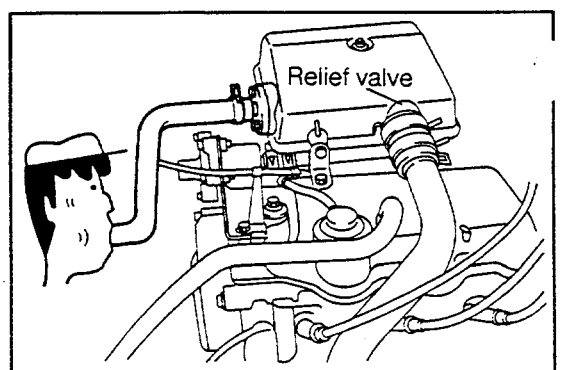
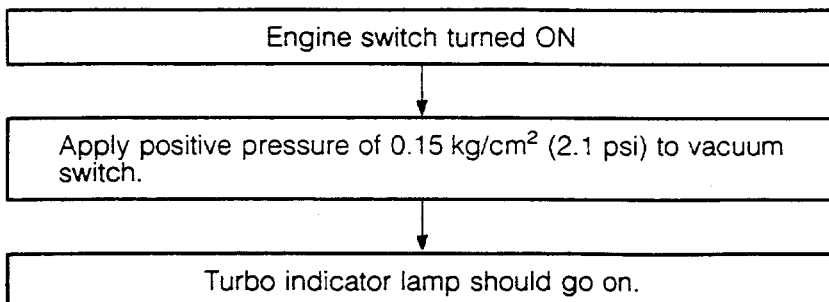

Fig. 11-9

WM-11010

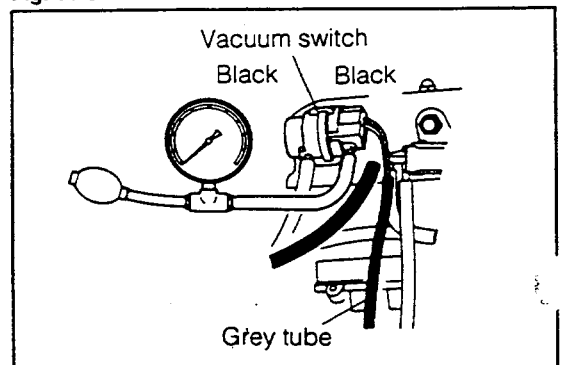
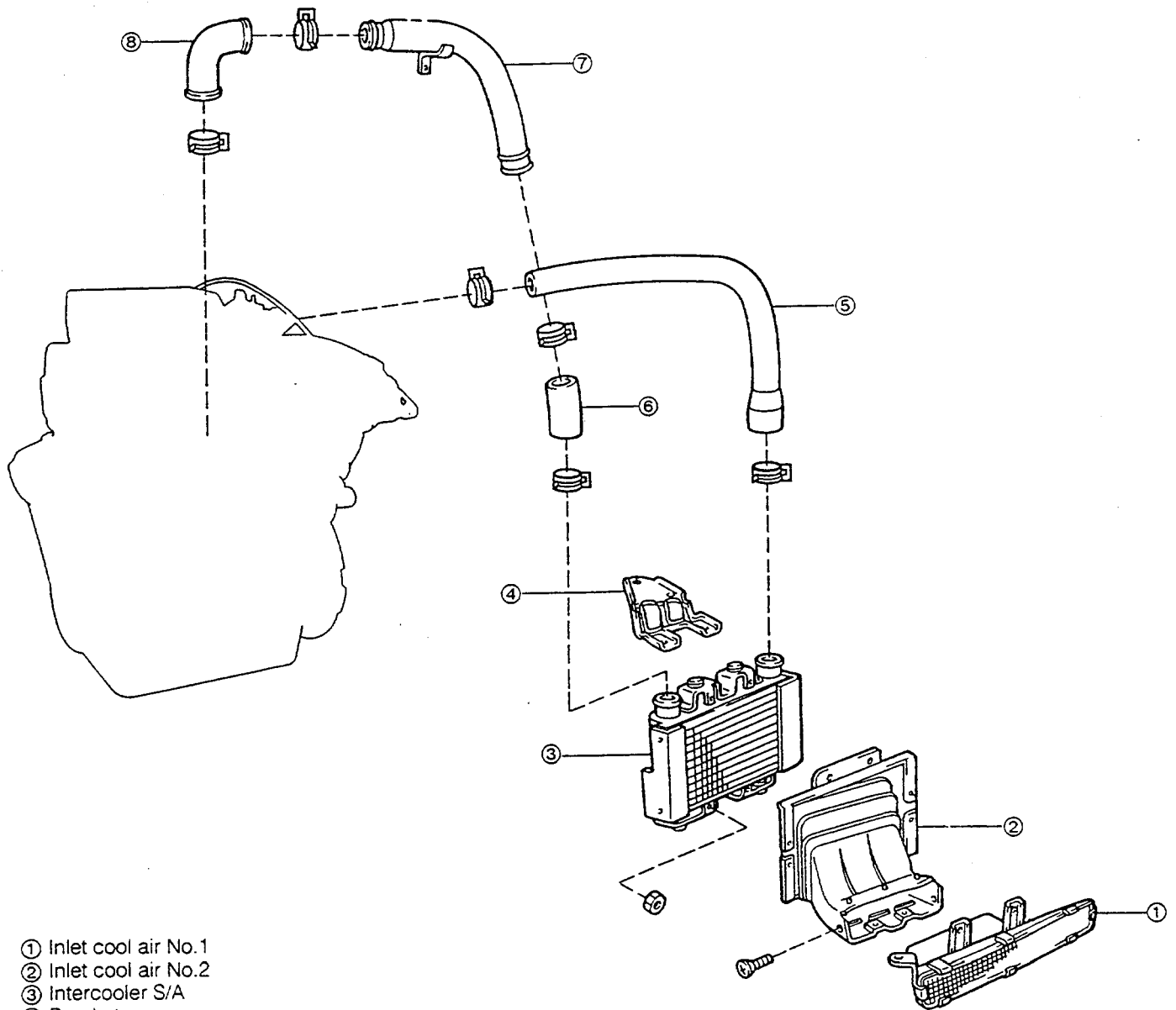

Fig. 11-10

WM-11011

INTERCOOLER

COMPONENTS OF INTERCOOLER [CB-80 Engine]



- ① Inlet cool air No.1
- ② Inlet cool air No.2
- ③ Intercooler S/A
- ④ Bracket
- ⑤ Hose
- ⑥ Hose
- ⑦ Intake pipe
- ⑧ Hose

Fig. 11-11

WM-11012

INTAKE SYSTEM

INSPECTION

1. Check the core section of the intercooler for restriction.
2. Check the core section of the intercooler for damage.
3. Check the intercooler for air leakage.
Tightly seal the intake and discharge ports of the intercooler, using sealing tape or the like. Submerge the intercooler into the water in a water tank. This water should be heated in advance up to about 50°C. Check to see if the intercooler exhibits air leakage. Replace the intercooler if it exhibits air leakage.

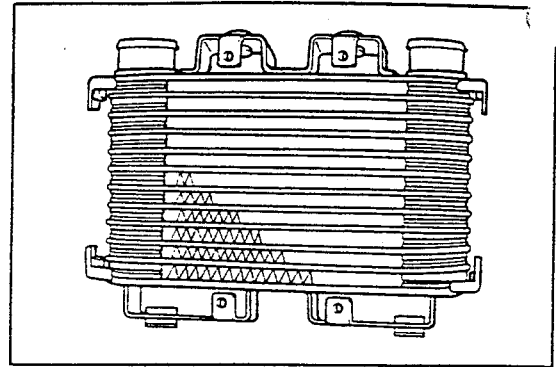

Fig. 11-12

WM-11013

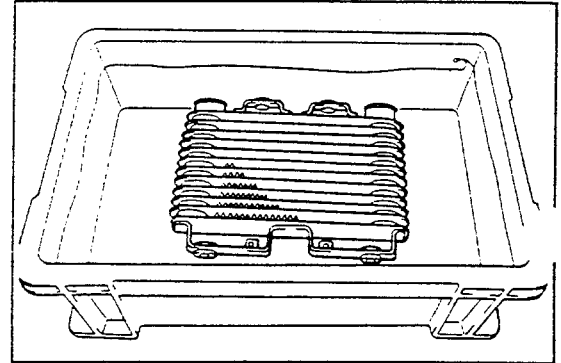

Fig. 11-13

WM-11014

DAIHATSU
TYPE CB
ENGINE

[CB-23, CB-61 & CB-80]

SECTION 12 EMISSION CONTROL SYSTEM

LIST OF DESTINATIONS	12- 2	CHOKE WARNING SYSTEM	12-30
SCHEMATIC VIEW OF EMISSION CONTROL SYSTEM	12- 3	CHECK	12-30
BLOW-BY GAS RECIRCULATION SYSTEM	12-20	FUEL CUT SYSTEM DURING DECELERATION	12-31
INSPECTION	12-22	OPERATING CONDITIONS OF SYSTEM	12-31
CHOKE OPENER SYSTEM	12-22	SYSTEM CHECK	12-32
SYSTEM CHECK	12-23	UNIT CHECK	12-32
UNIT CHECK	12-23	VACUUM SWITCH	12-32
DASHPOT SYSTEM	12-24	OUTER VENT SYSTEM	12-33
SYSTEM CHECK	12-25	UNIT CHECK	12-34
UNIT CHECK	12-25	IGNITION TIMING CONTROL SYSTEM	
FUEL EVAPORATIVE EMISSION CONTROL SYSTEM	12-25	CHECK [CB-23 Engine]	12-35
CHARCOAL CANISTER	12-26	MAIN SIDE	12-35
INSPECTION	12-26	SUB SIDE	12-35
MAIN AIR BLEED	12-26	UNIT CHECK	12-36
OPERATION CHECK OF VCV	12-27	IGNITION TIMING CONTROL SYSTEM	
SECONDARY AIR SUCTION SYSTEM (AS SYSTEM)	12-27	CHECK [CB-61 Engine]	12-37
CHECKING OF SECONDARY AIR SUCTION SYSTEM	12-27	IGNITION TIMING CONTROL	
AIR SUCTION FILTER ELEMENT	12-28	SYSTEM CHECK	12-37
EGR (EXHAUST GAS RECIRCULATING) SYSTEM	12-28	UNIT CHECK	12-38
EGR SYSTEM CHECK	12-28	CHECK AND ADJUSTMENT OF	
UNIT INSPECTION	12-29	IGNITION TIMING	12-38

1

EMISSION CONTROL SYSTEM

LIST OF DESTINATIONS

Engine type Destination Transmission type		Blow-by gas recirculating system	Choke warning	Ignition timing control system	Choke opener	Dashpot	Outer vent system	Fuel cut during deceleration	Secondary air suction	Catalyst	Main air bleeder	Exhaust gas recirculating system	Fuel evaporative emission control system
CB-23	General specifications Manual transmission	○	—	○	—	—	—	—	—	—	—	—	—
	General specifications Automatic transmission	○	—	○	—	—	—	—	—	—	—	—	—
	Australian specifications Manual transmission	○	○	○	○	○	○	○	○	○	—	—	○
	Australian specifications Automatic transmission	○	○	○	○	○	○	○	○	○	—	—	○
	ECE & EEC specifications Manual transmission	○	○	○	○	○	—	—	—	—	—	—	—
	ECE & EEC specifications Automatic transmission	○	○	○	○	—	—	—	—	—	—	—	—
	Saudi Arabian (GCC) specifications Manual transmission	○	—	○	○	○	—	—	—	—	—	—	—
	Saudi Arabian (GCC) specifications Automatic transmission	○	—	○	○	—	—	—	—	—	—	—	—
	Singapore specifications Manual transmission	○	—	○	○	○	—	—	—	—	—	—	—
	Singapore specifications Automatic transmission	○	—	○	○	—	—	—	—	—	—	—	—
	Swedish specifications Manual transmission	○	○	○	○	○	—	—	—	—	—	—	—
Swiss specifications Manual transmission	○	○	○	○	○	—	○	○	○	—	○	—	
CB-61	General specifications Manual transmission	○	—	○	—	—	—	—	—	—	—	—	—
	Australian specifications Manual transmission	○	○	○	○	○	○	○	○	○	○	—	○
	ECE & EEC specifications Manual transmission	○	○	○	○	○	—	—	—	—	—	—	—
	Singapore specifications Manual transmission	○	○	○	○	○	—	—	—	—	—	—	—
	Swedish specifications Manual transmission	○	○	○	○	○	—	—	—	—	—	—	—
West German specifications Manual transmission	○	○	○	○	○	—	○	○	○	○	—	—	
CB-80	All specifications Manual transmission	○	○	Electronic timing advance	—	—	—	—	—	—	—	—	○
CL-11	All specifications Manual transmission	○	—	—	—	—	—	—	—	—	—	—	—
CL-61	All specifications Manual transmission	○	—	—	—	—	—	—	—	—	—	—	—

WM-12002

SCHEMATIC VIEW OF EMISSION CONTROL SYSTEMS

General Specifications with CB-23 Engine and Manual Transmission

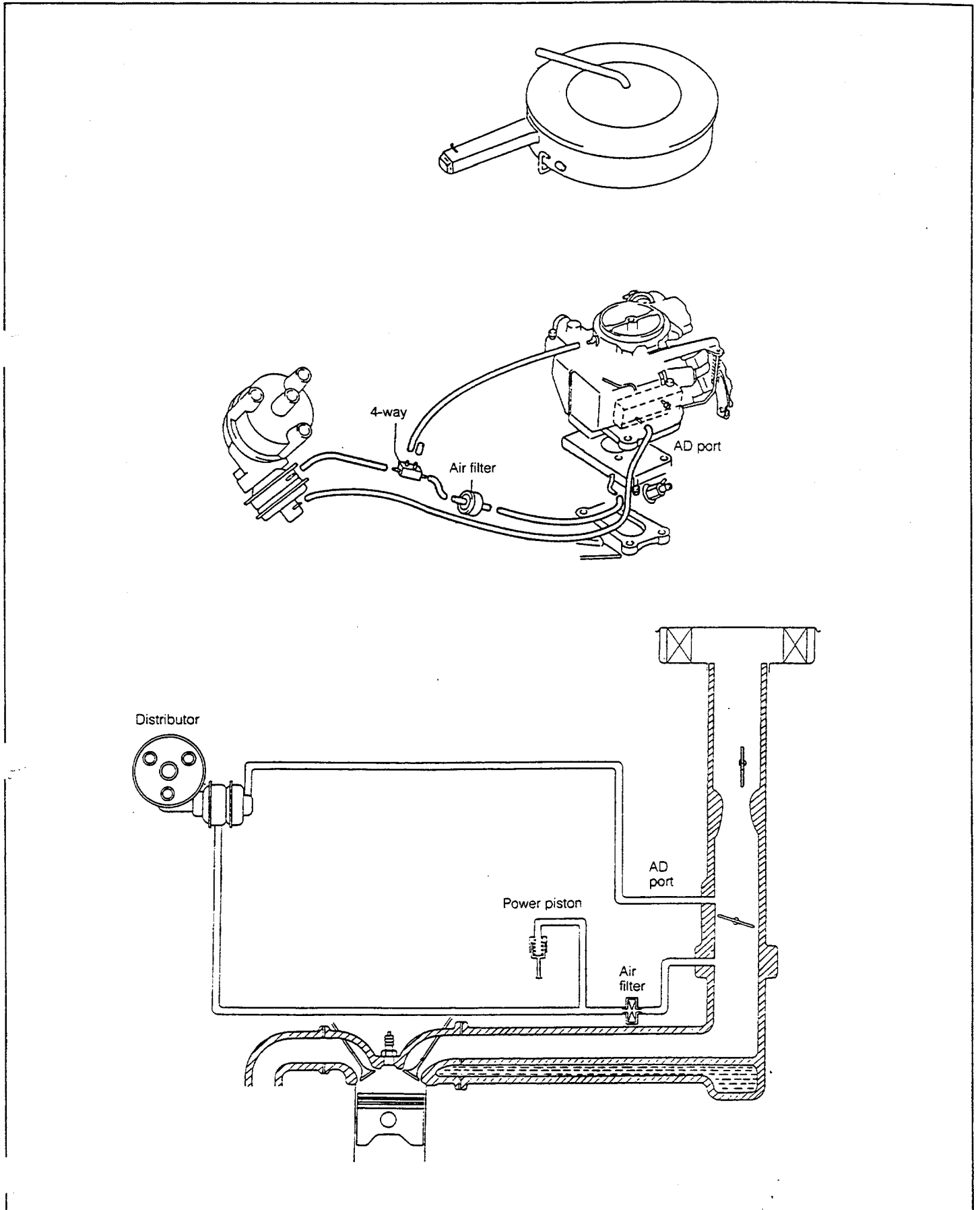

Fig. 12-1

WM-12003

EMISSION CONTROL SYSTEM

General Specifications with CB-23 Engine and Automatic Transmission

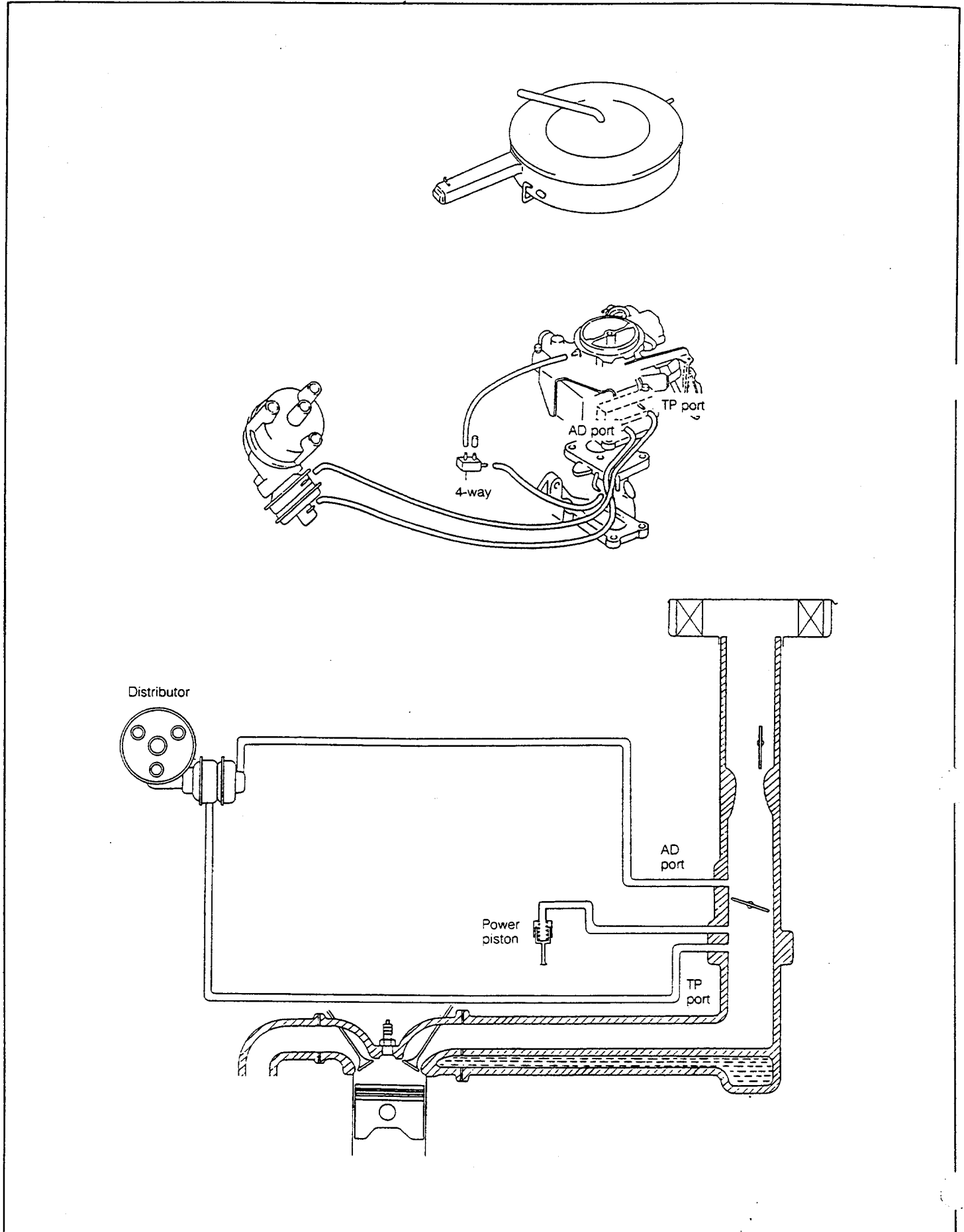

Fig. 12-2

WM-12004

Australian Specifications with CB-23 Engine and Automatic Transmission

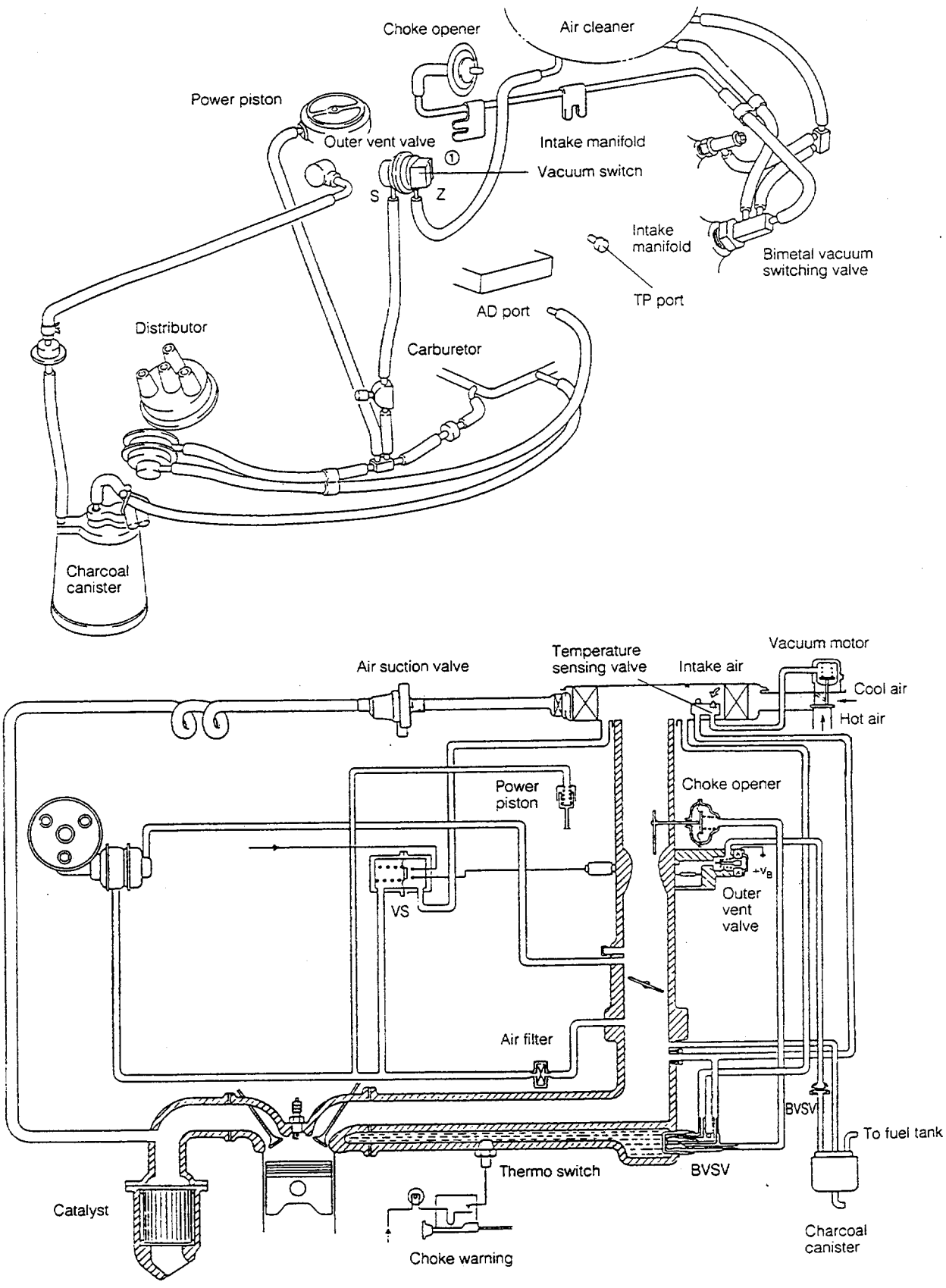

Fig. 12-3

WM-12005

EMISSION CONTROL SYSTEM

Australian Specifications with CB-23 Engine and Manual Transmission

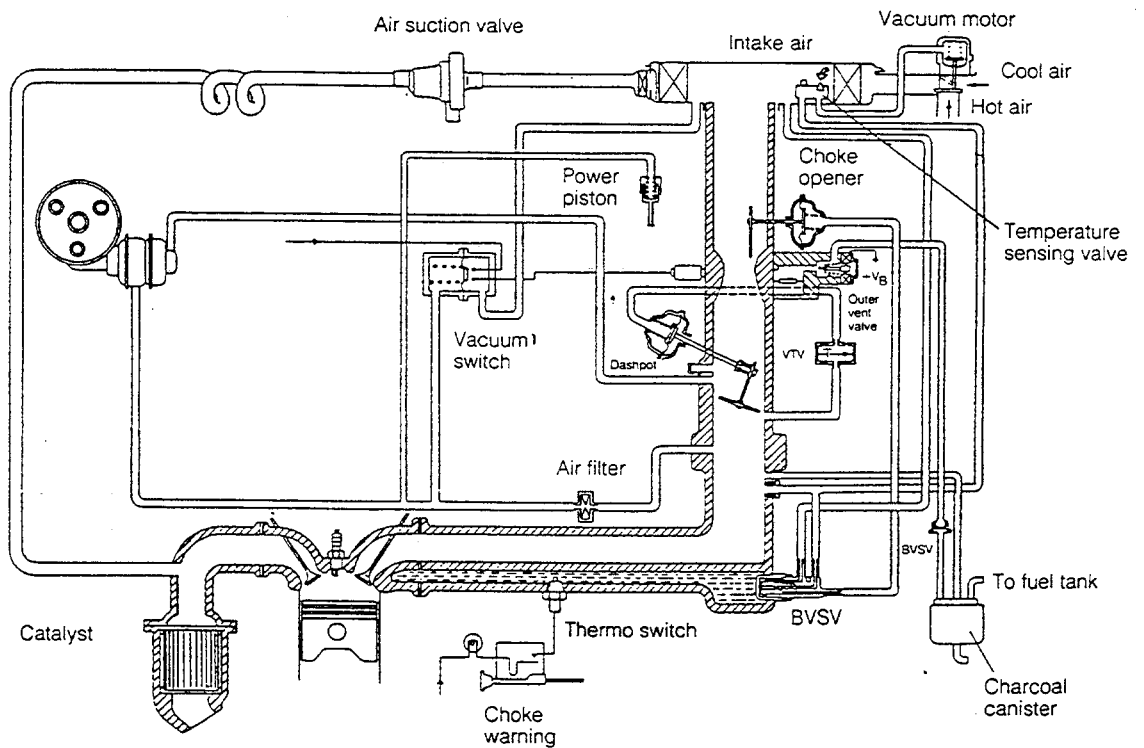
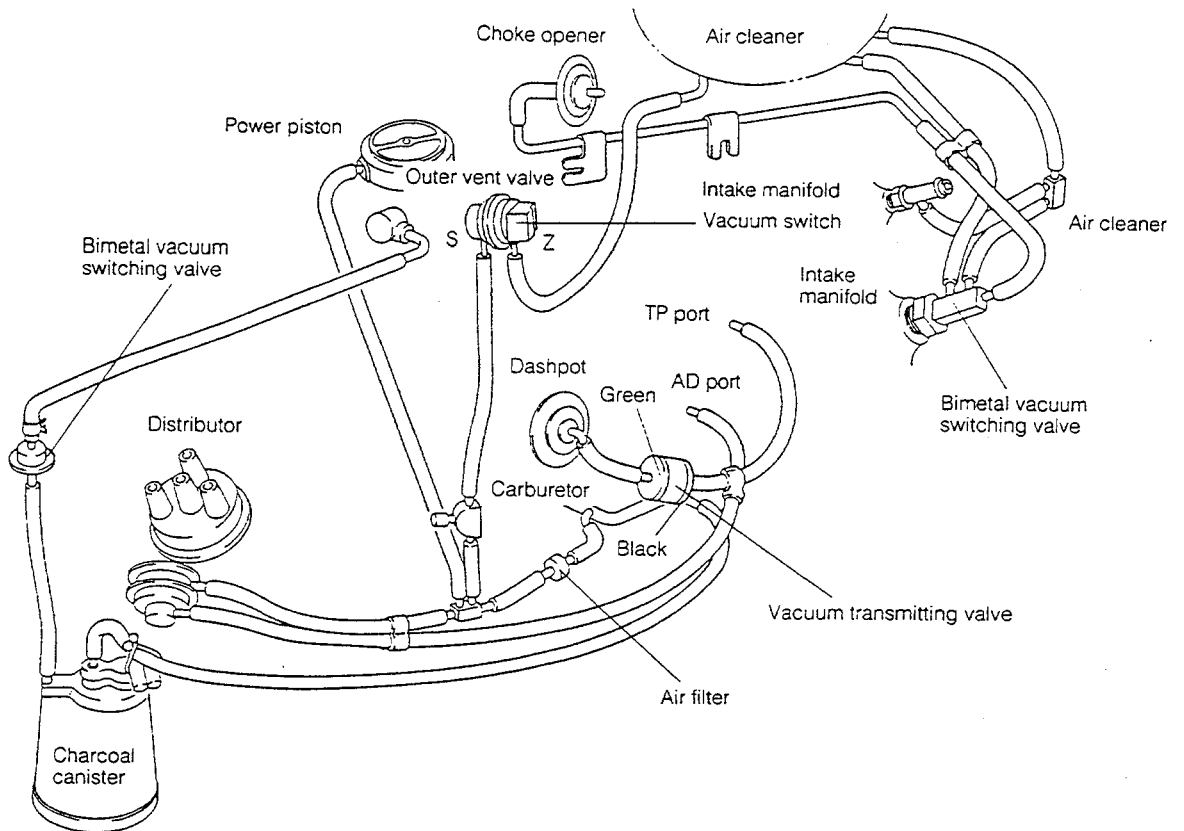

Fig. 12-4

E & EEC Specifications with CB-23 Engine and Manual Transmission

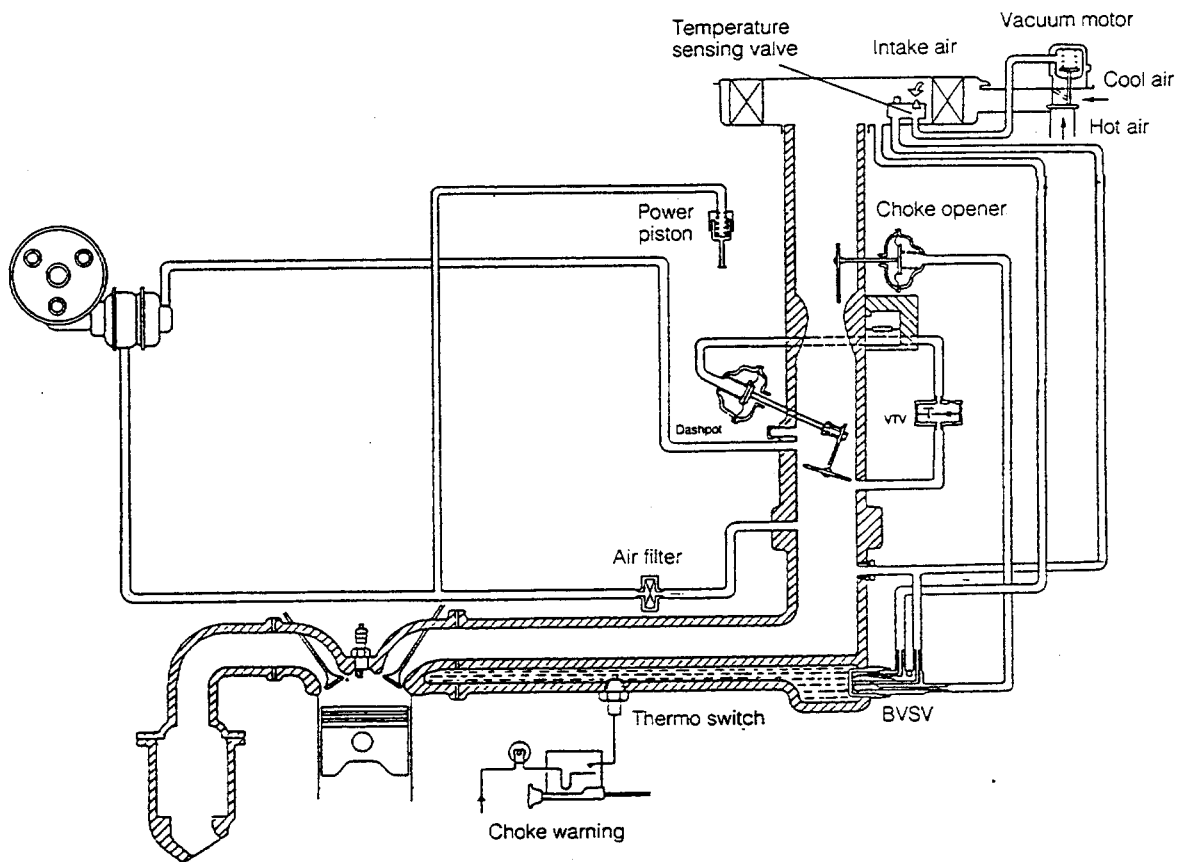
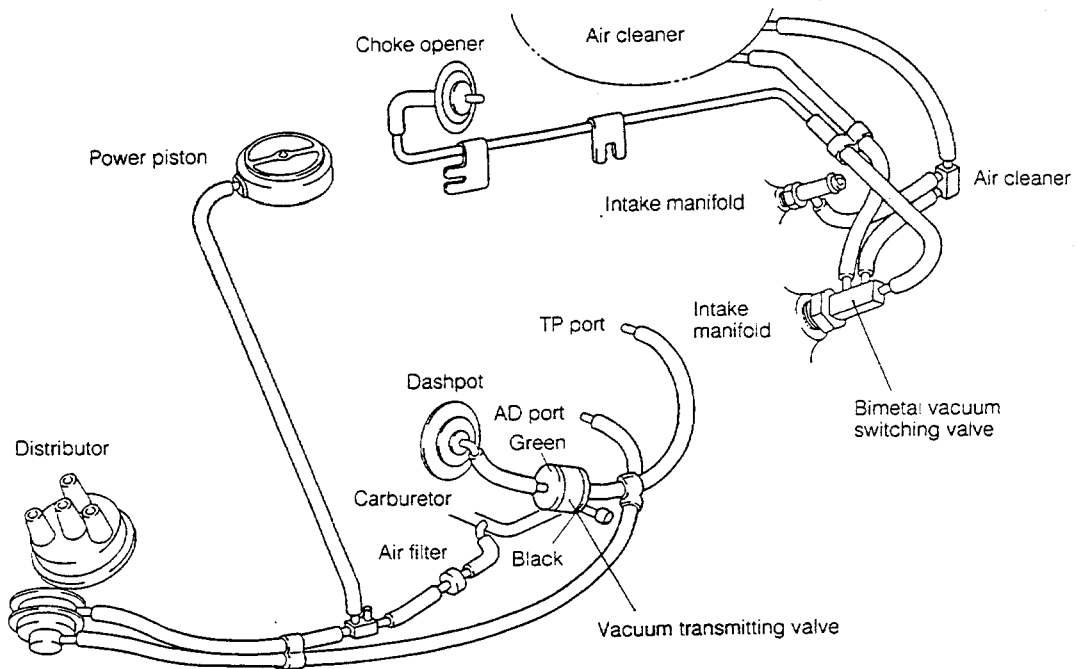

Fig. 12-5

WM-12007

EMISSION CONTROL SYSTEM

ECE & EEC Specifications with CB-23 Engine and Automatic Transmission

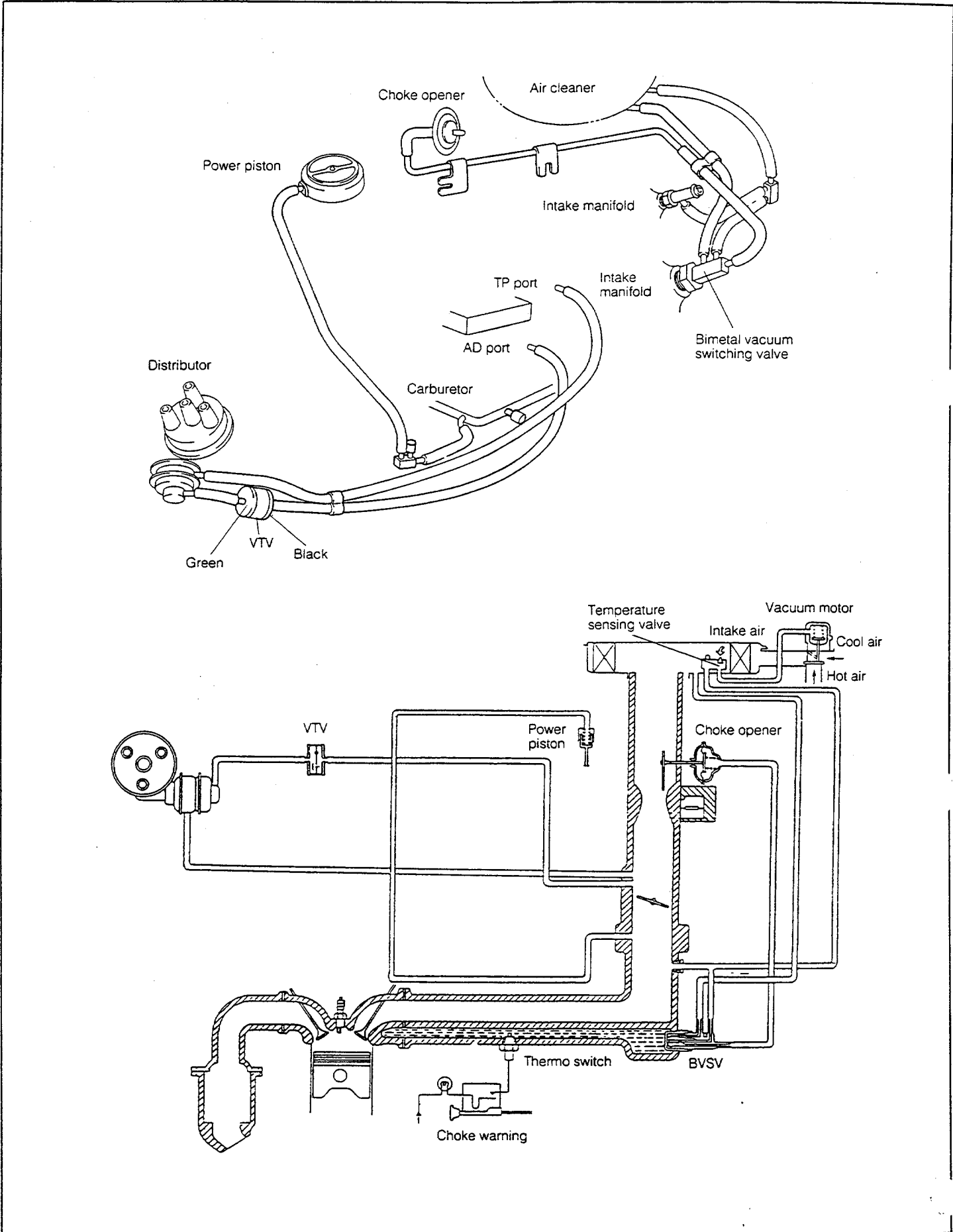

Fig. 12-6

WM-12008

Saudi Arabian (GCC) Specifications with CB-23 Engine and Manual Transmission

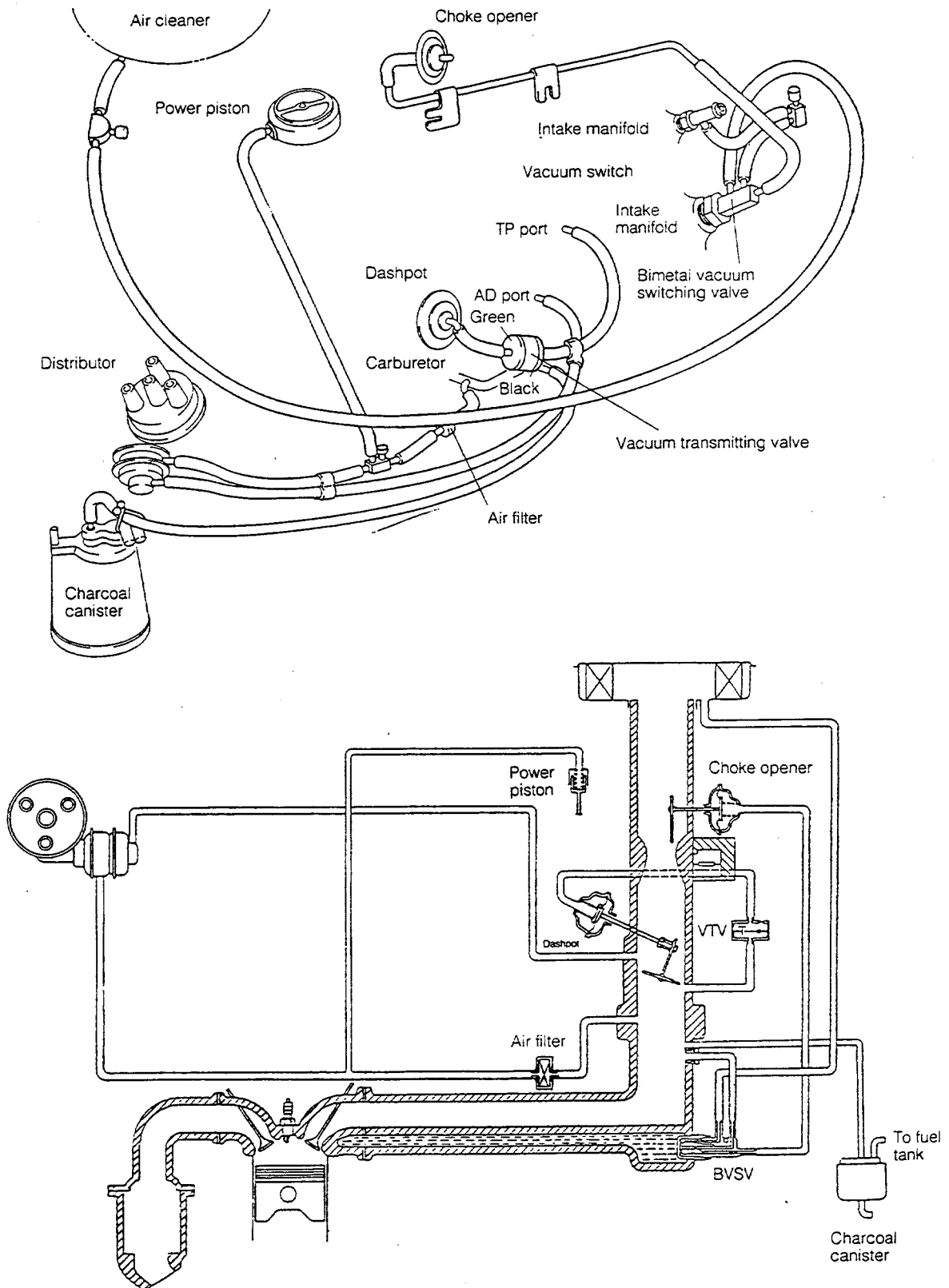

Fig. 12-7

EMISSION CONTROL SYSTEM

Saudi Arabian Specifications with CB-23 Engine and Automatic Transmission

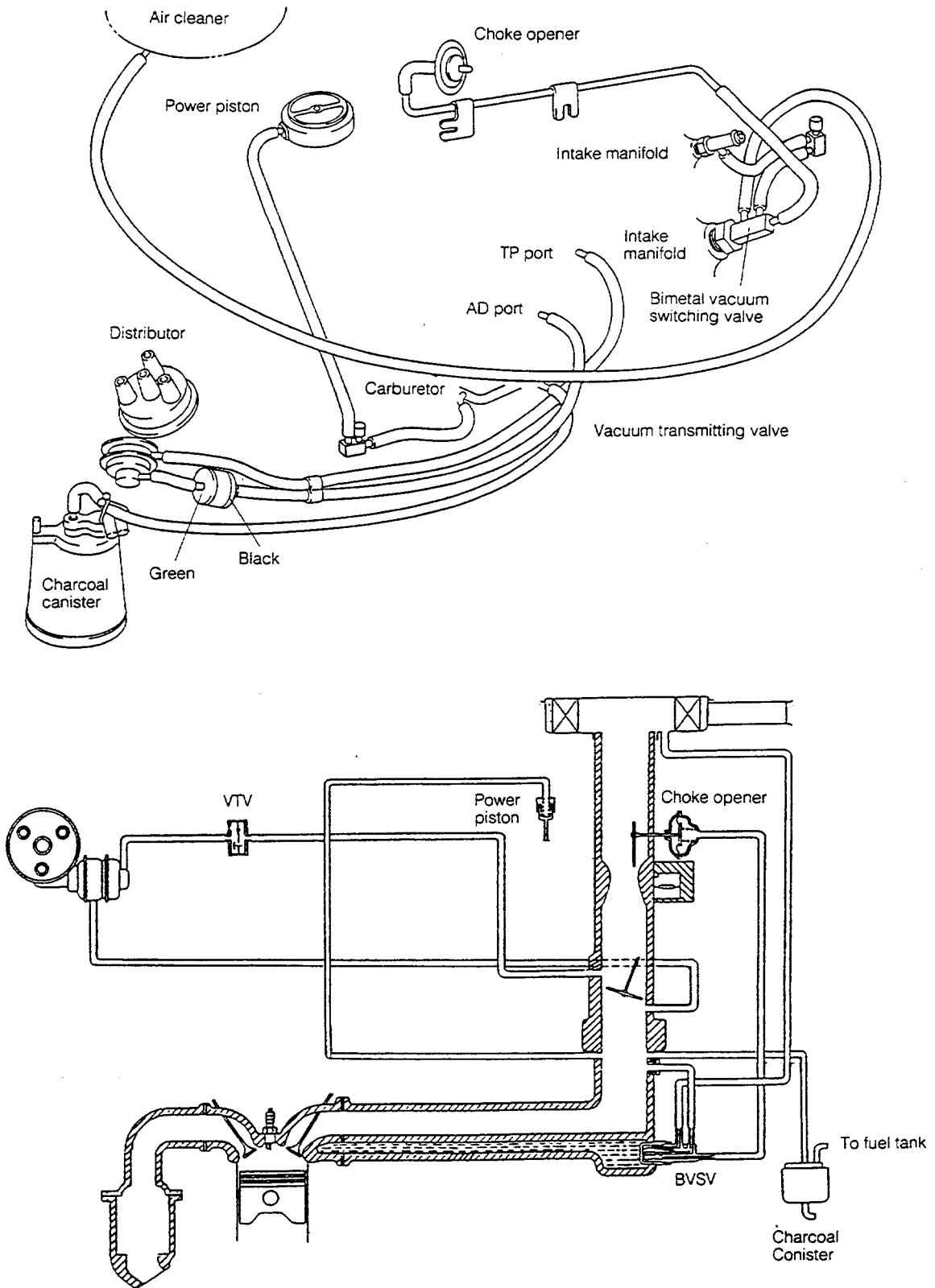

Fig. 12-8

igapore Specifications with CB-23 Engine and Manual Transmission

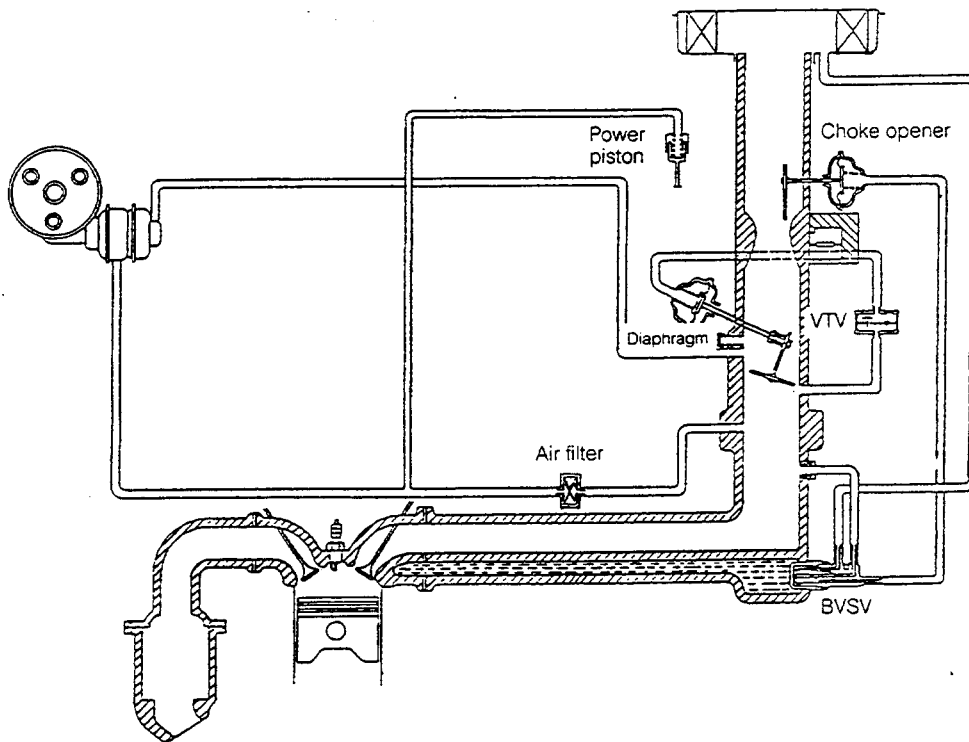
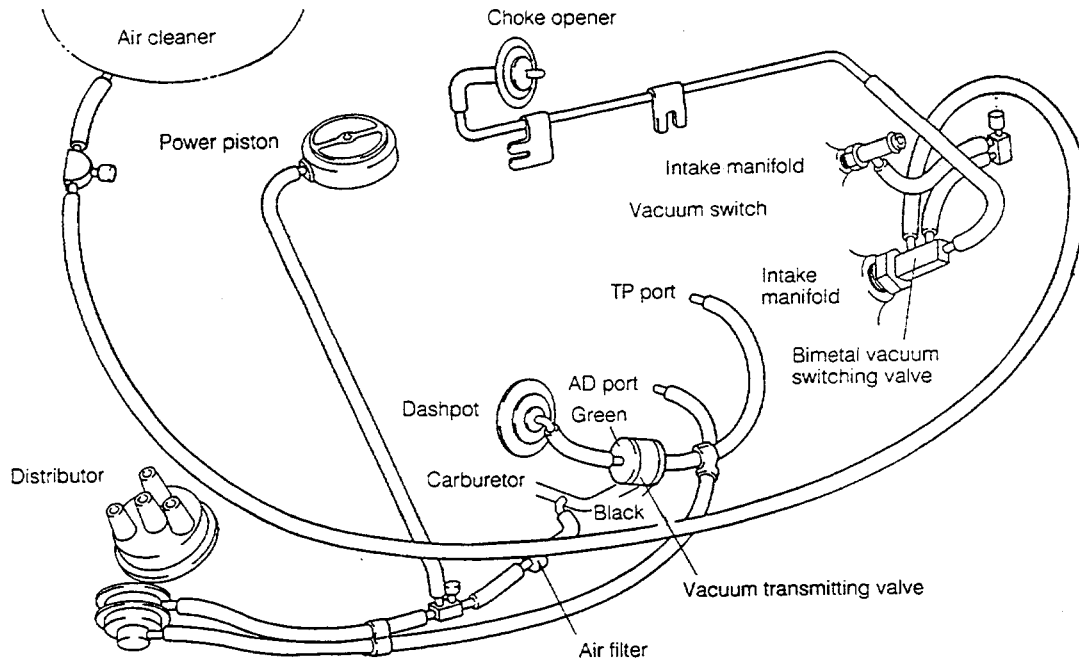

Fig. 12-9

EMISSION CONTROL SYSTEM

Singapore Specifications with CB-23 Engine and Automatic Transmission

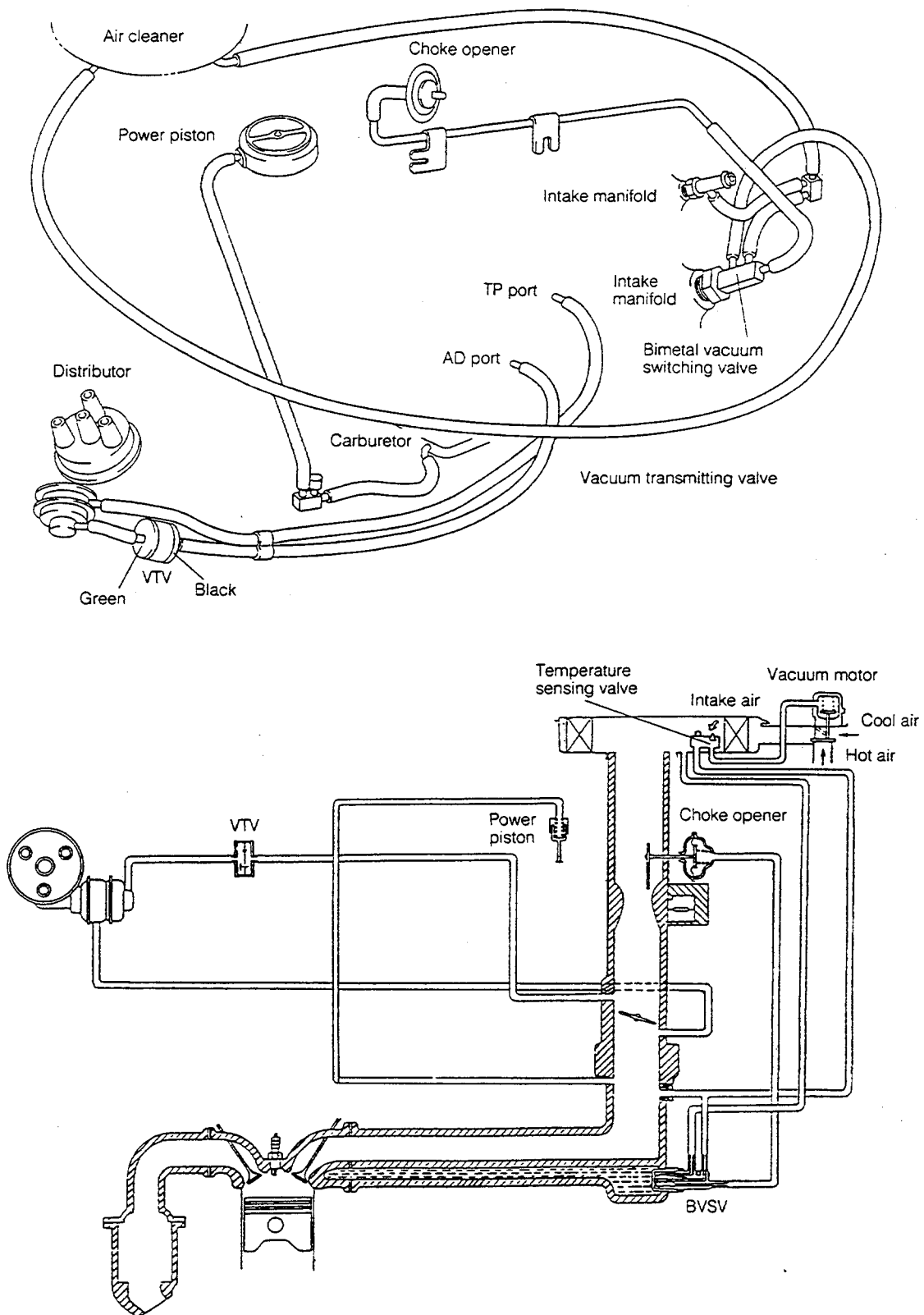

Fig. 12-10

WM-12012

vedish Specifications with CB-23 Engine and Manual Transmission

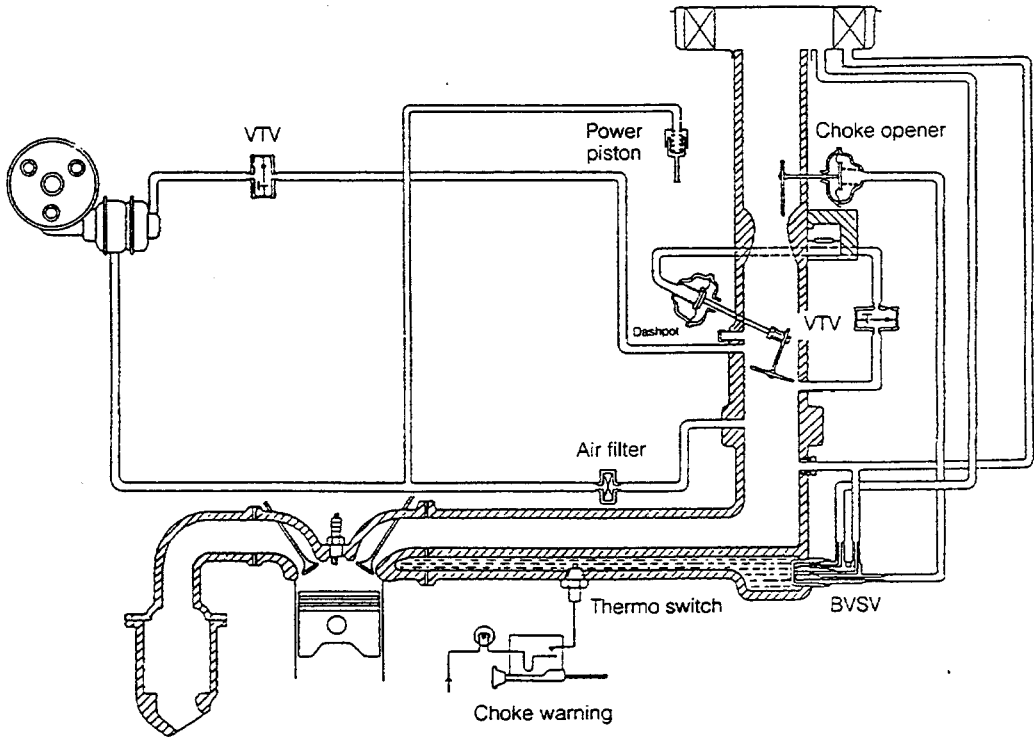
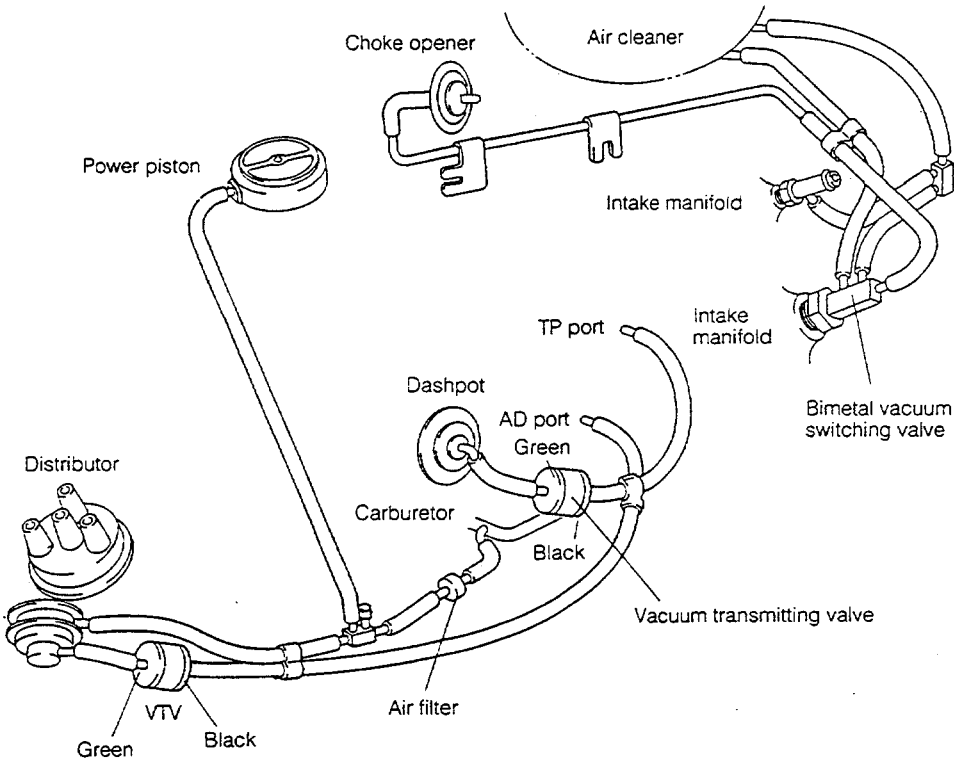

Fig. 12-11

EMISSION CONTROL SYSTEM

Swiss Specifications with CB-23 Engine and Manual Transmission

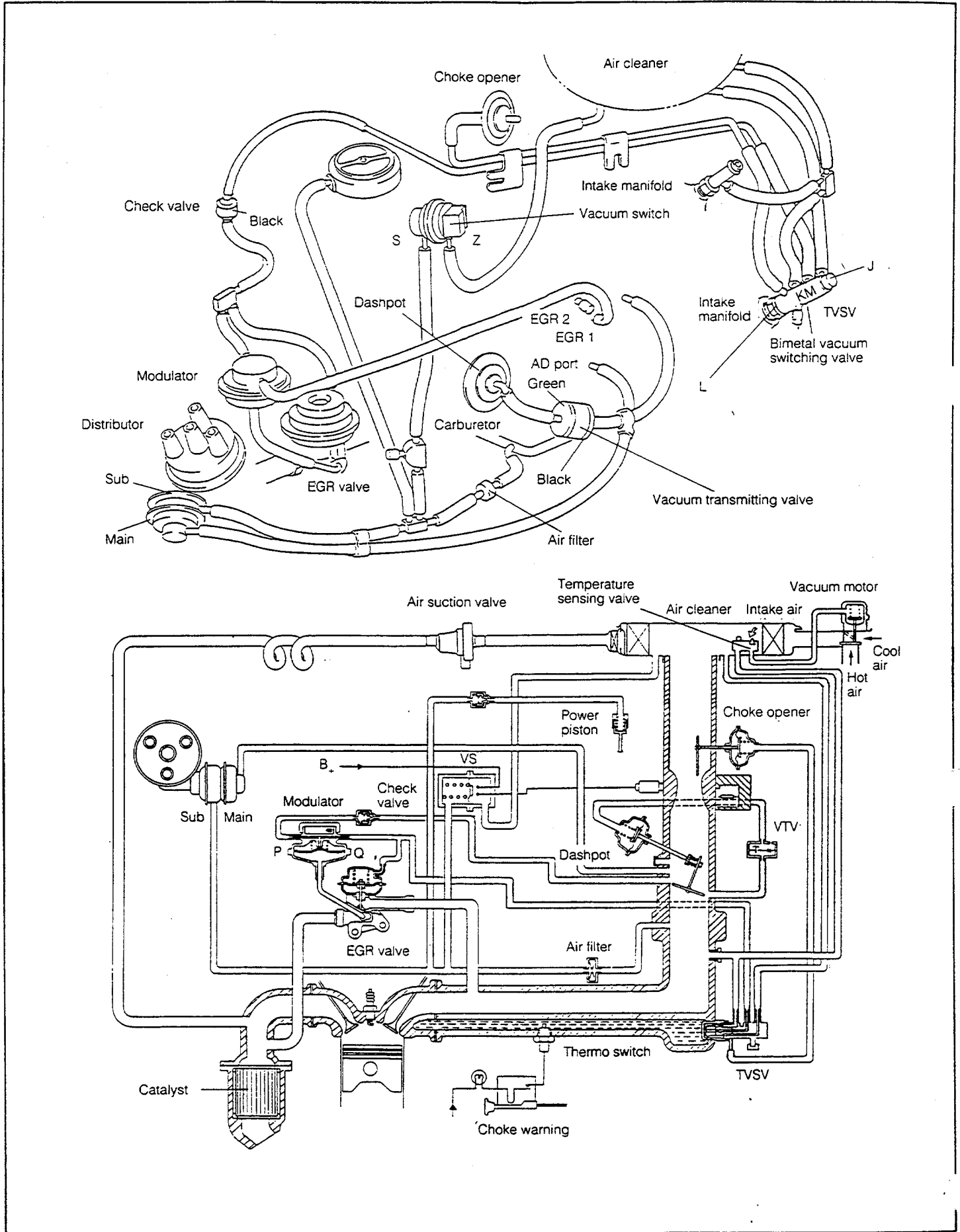

Fig. 12-12

WM-12014

General Specifications with CB-61 Engine

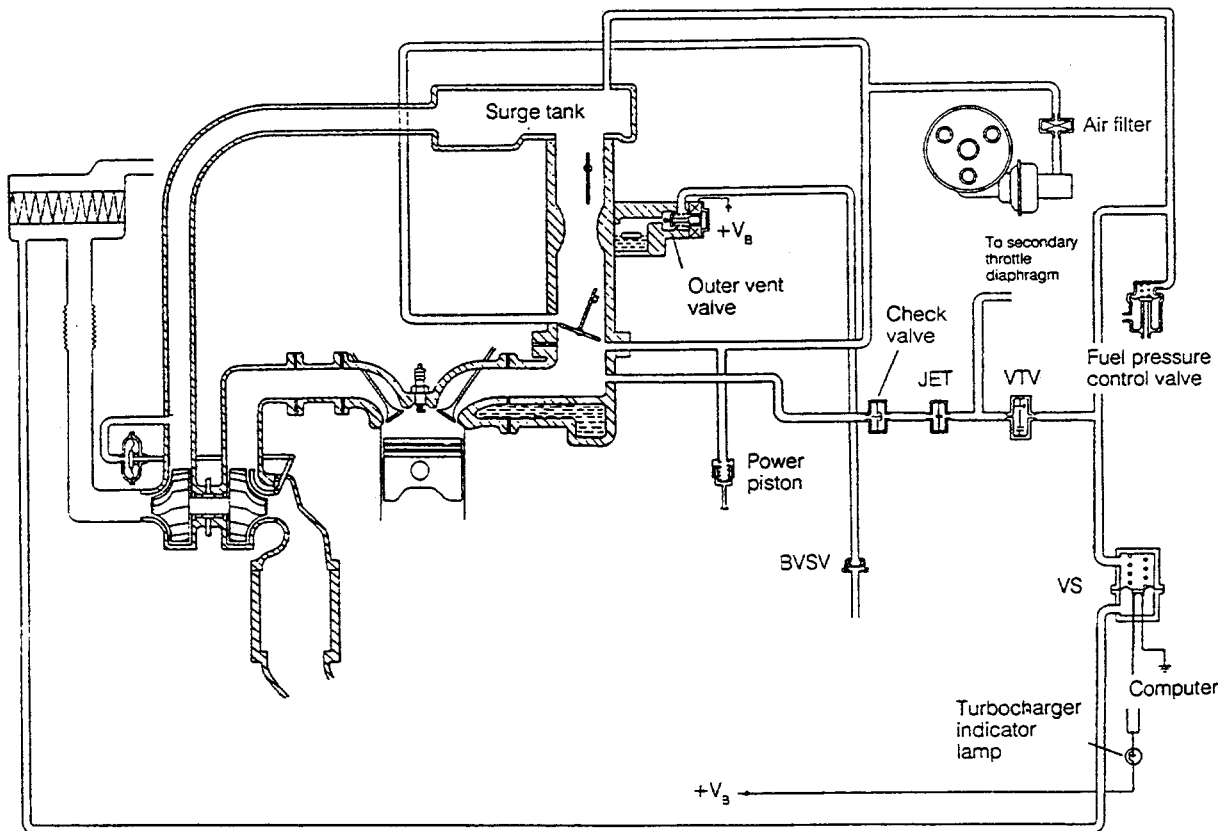
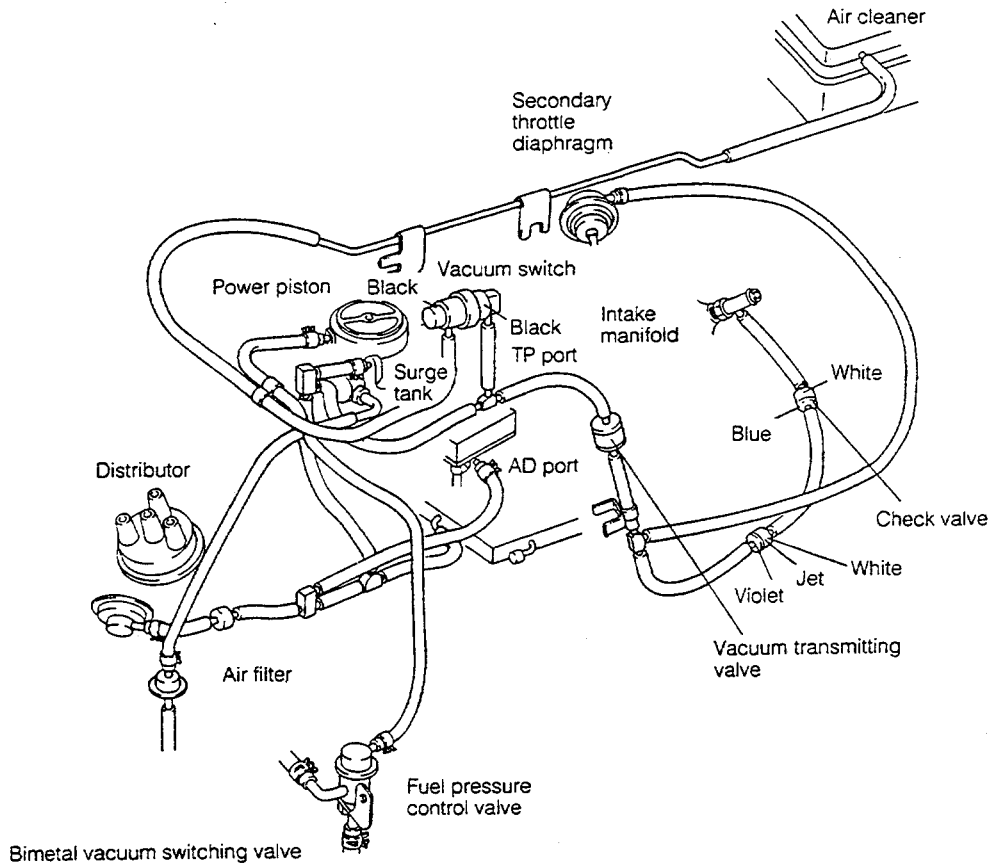

Fig. 12-13

EMISSION CONTROL SYSTEM

Australian Specifications with CB-61 Engine

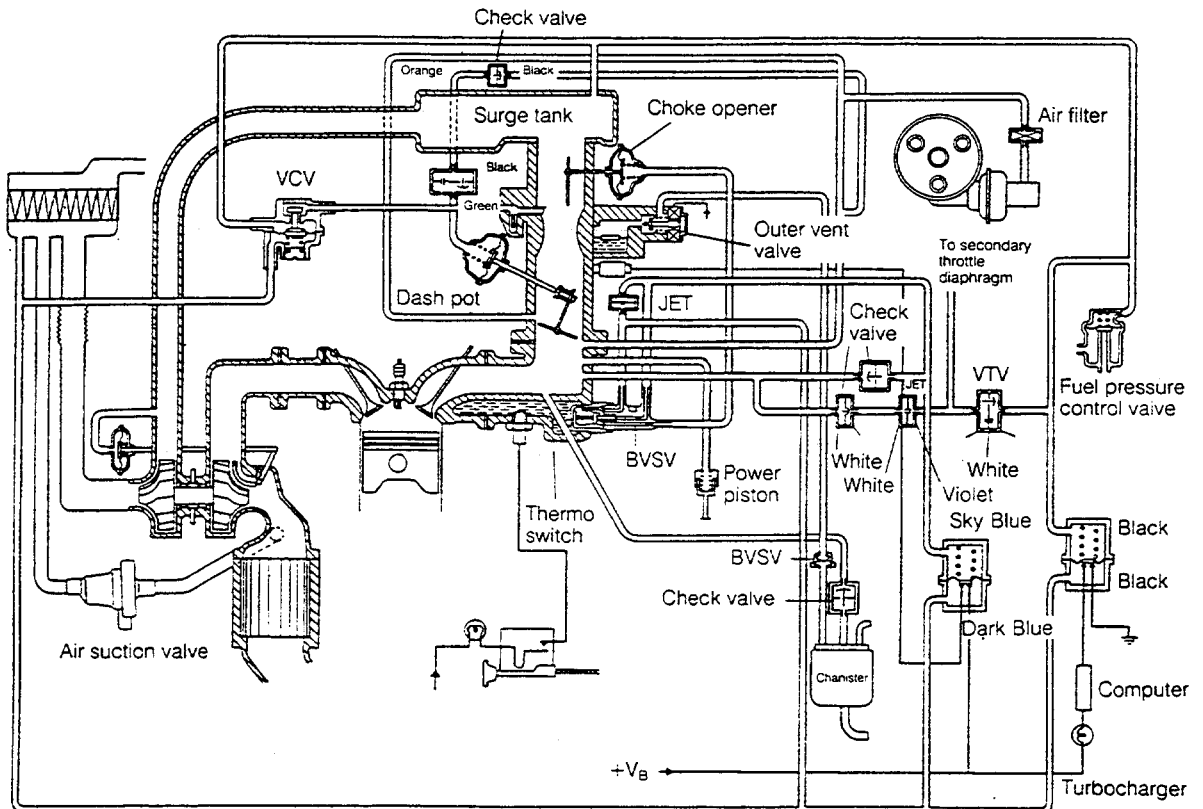
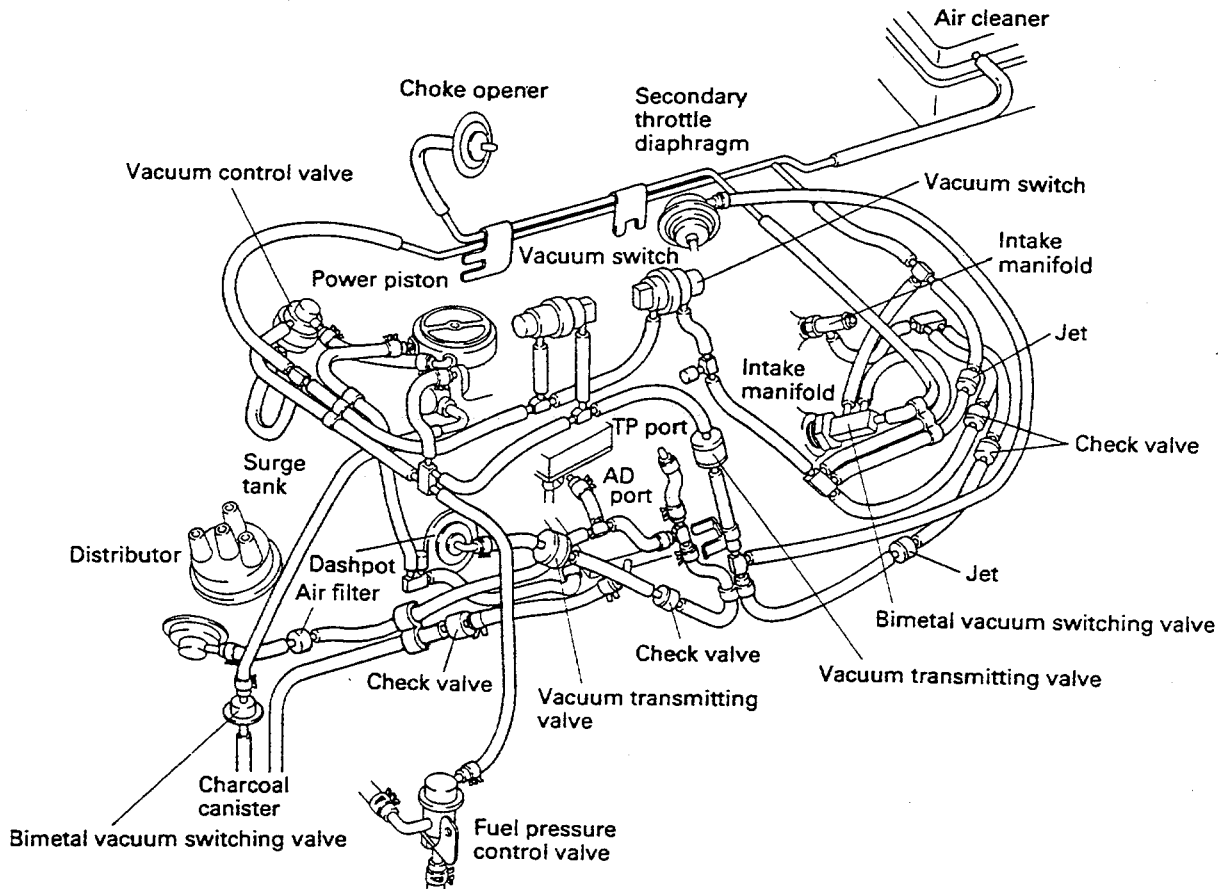

Fig. 12-14

ECE & EEC and Singapore Specifications with CB-61 Engine

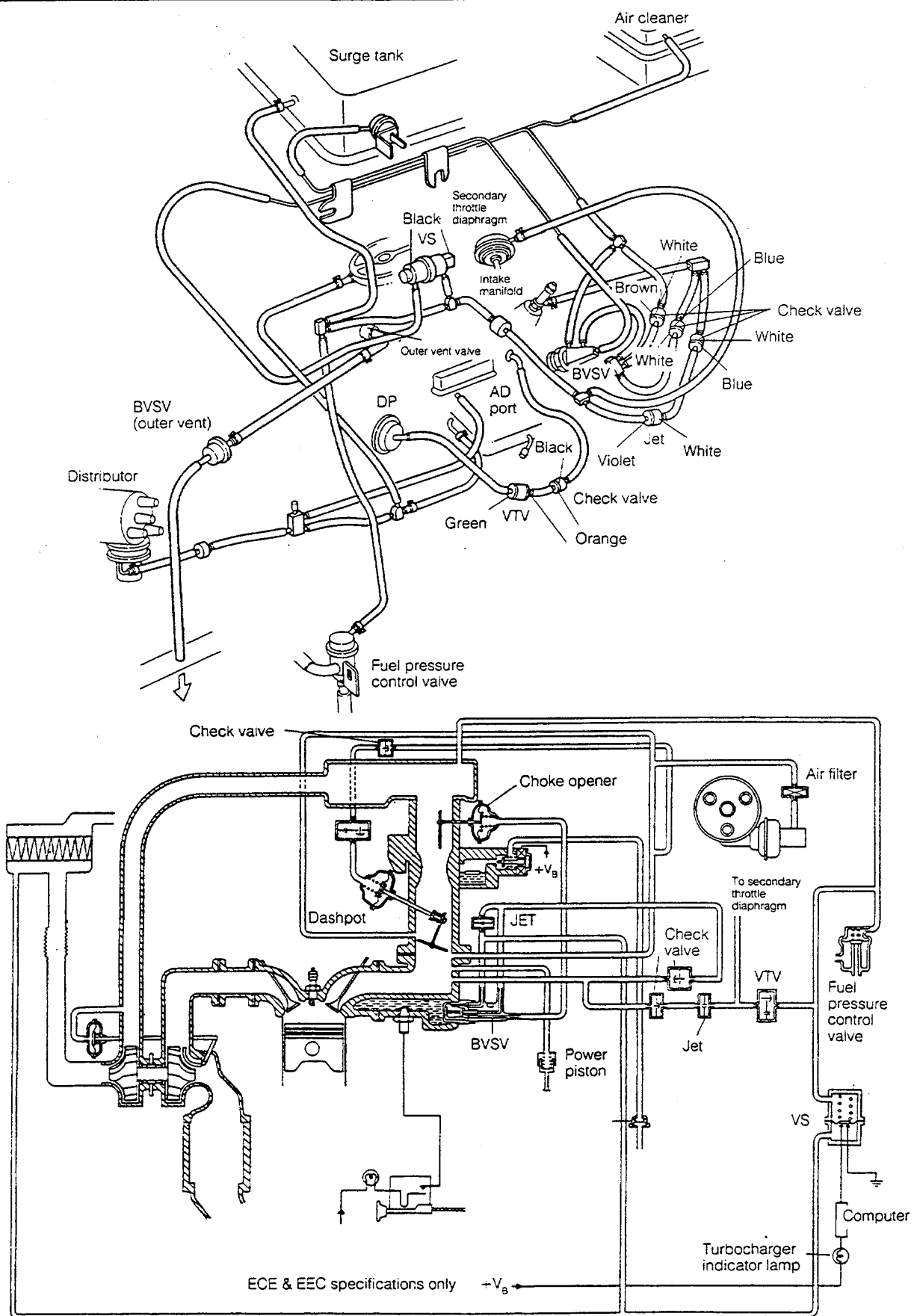

Fig. 12-15

WM-12017

EMISSION CONTROL SYSTEM

Swedish Specifications with CB-61 Engine

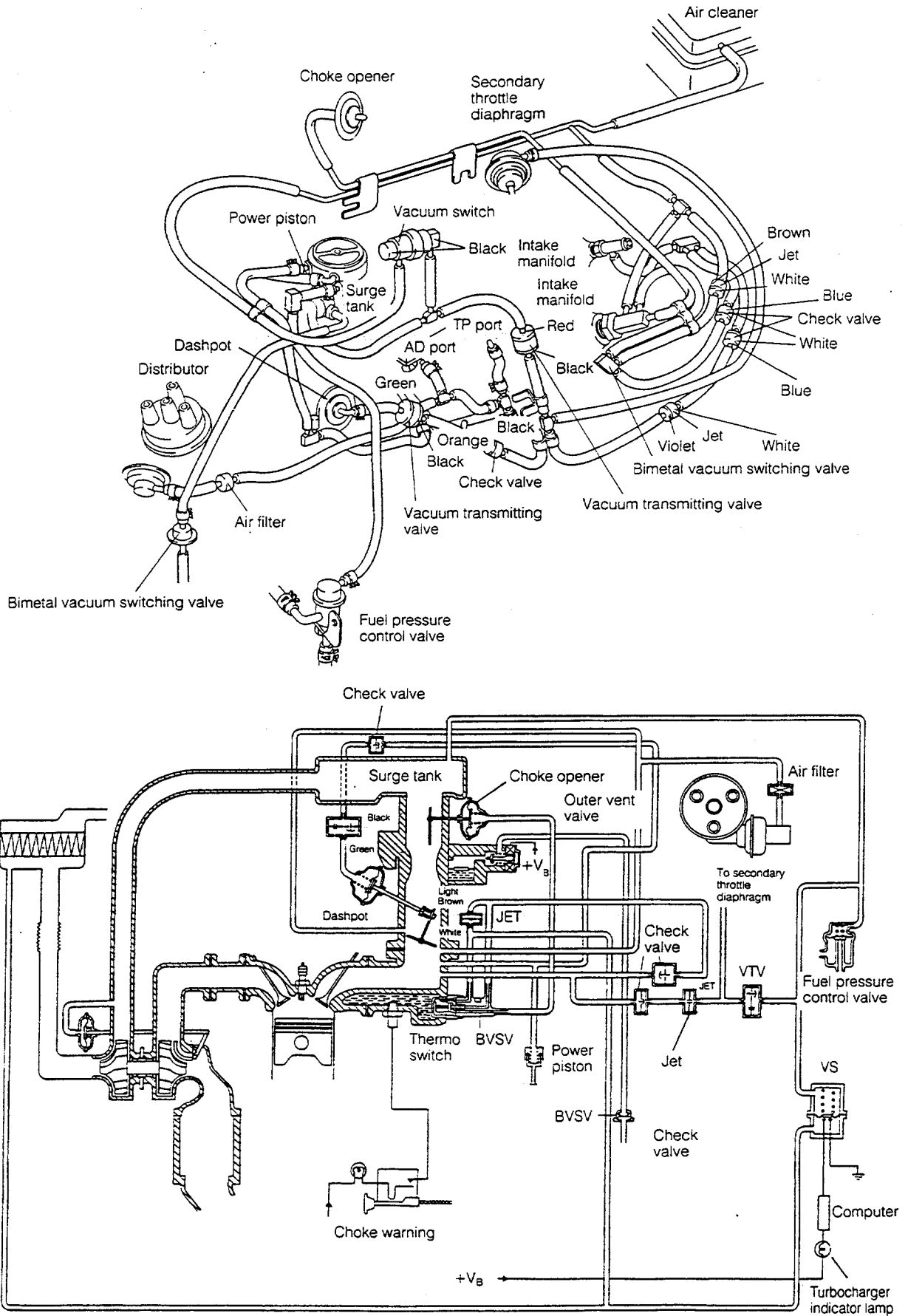

Fig. 12-16

WM-12018

est German Specifications with CB-61 Engine

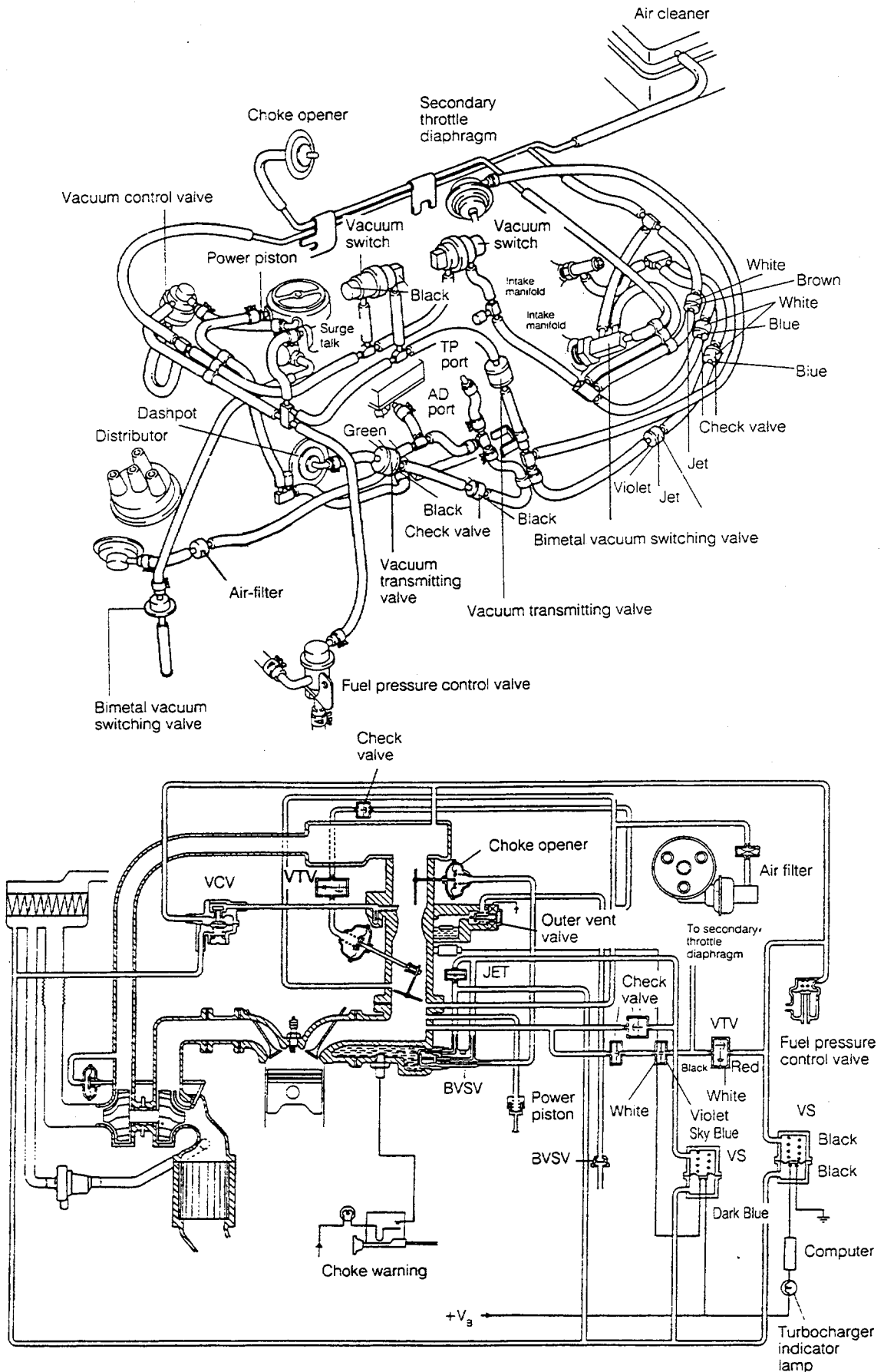

Fig. 12-17

EMISSION CONTROL SYSTEM

BLOW-BY GAS RECIRCULATION SYSTEM

Blow-by Gas Recirculating System (CB-23 Engine)

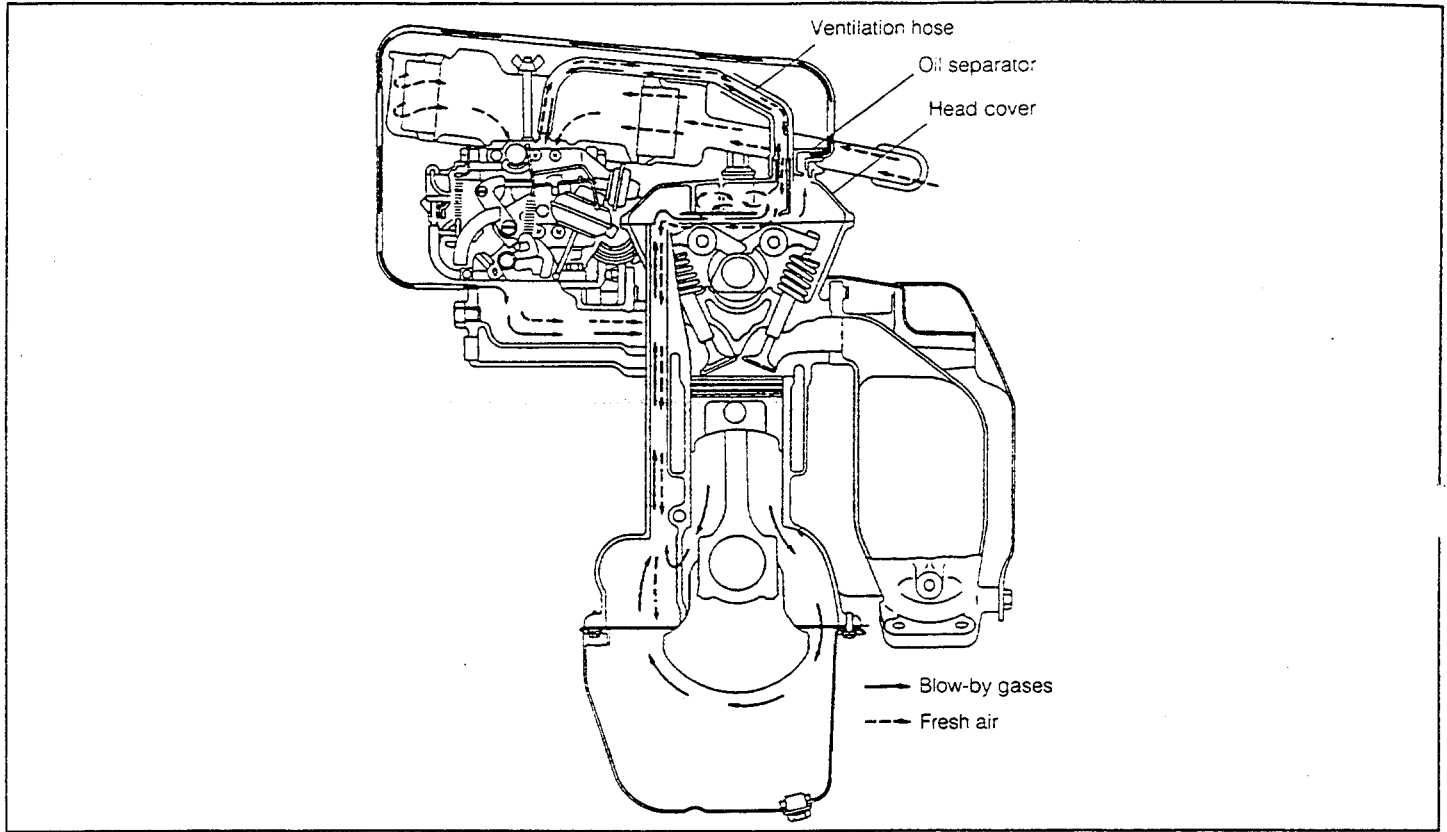

Fig. 12-18

WM-12020

Blow-by Gas Recirculating System (CB-80 Engine)

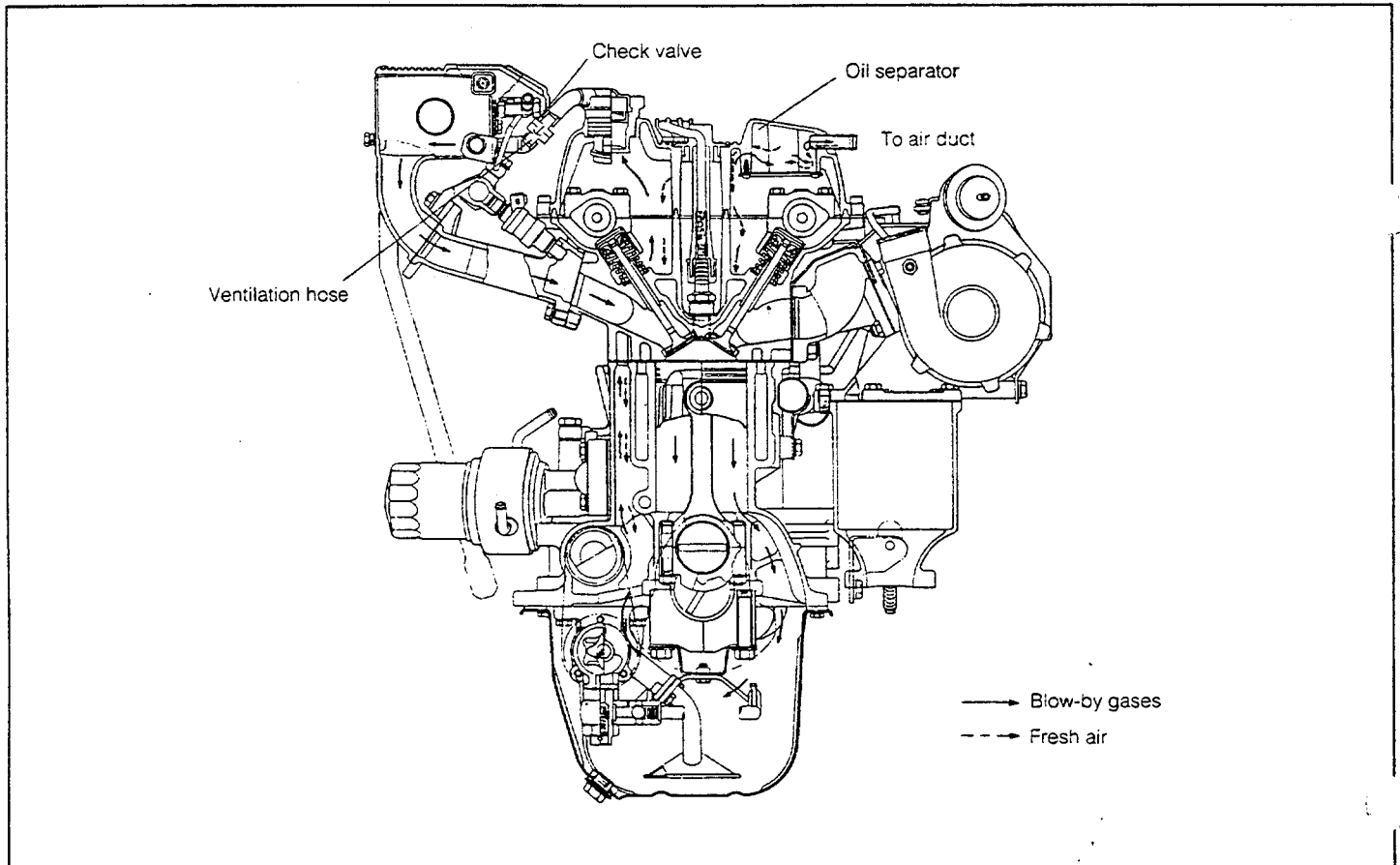

Fig. 12-19

WM-12021

ow-by Gas Recirculating System (CB-61 Engine)

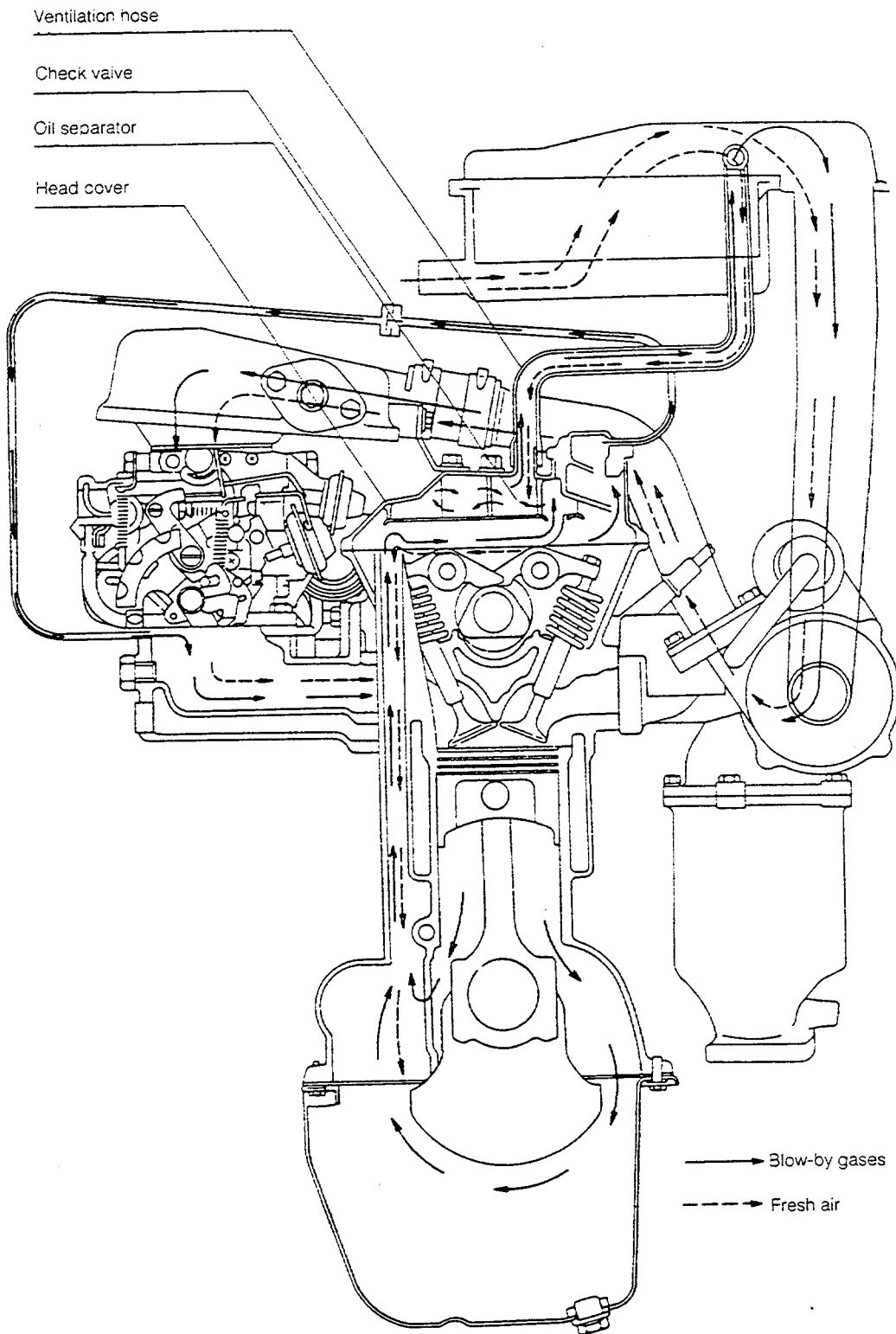

Fig. 12-20

EMISSION CONTROL SYSTEM

INSPECTION

Ventilation hose (1)

1. Ensure that the ventilation hoses exhibit no cracks, damage, or restriction.
2. Ensure that the baffle plate of the cylinder head cover exhibits no restriction.
3. Remove the oil filler cap. Lightly blow into the inside through the ventilation hose. If air continuity exists, it represents a normal operation.

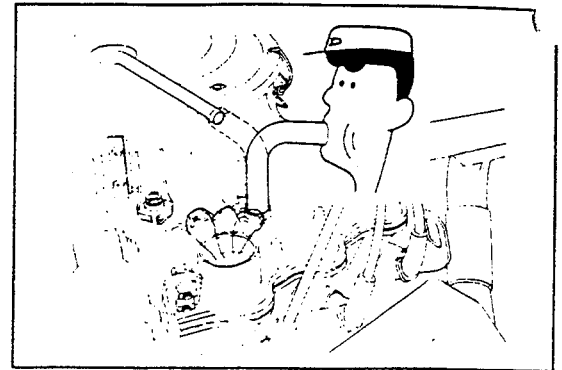

Fig. 12-21

WM-12023

Ventilation hose (2)

1. Disconnect the ventilation hose from the carburetor's insulator.
2. Ensure that the hose exhibits no cracks.
3. Damage or restriction.
4. Remove the oil filter cap. Strongly blow from the carburetor side. If air passes through, it represents a normal operation.

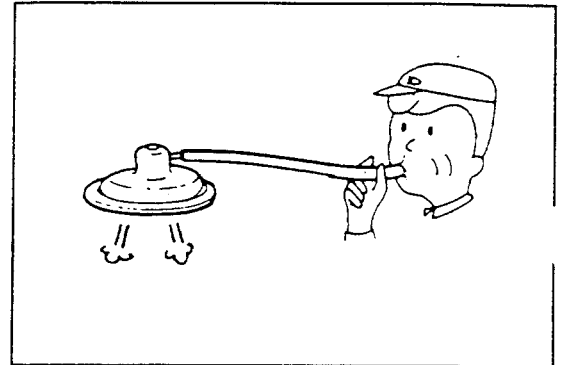

Fig. 12-22

WM-12024

CHOKE OPENER SYSTEM

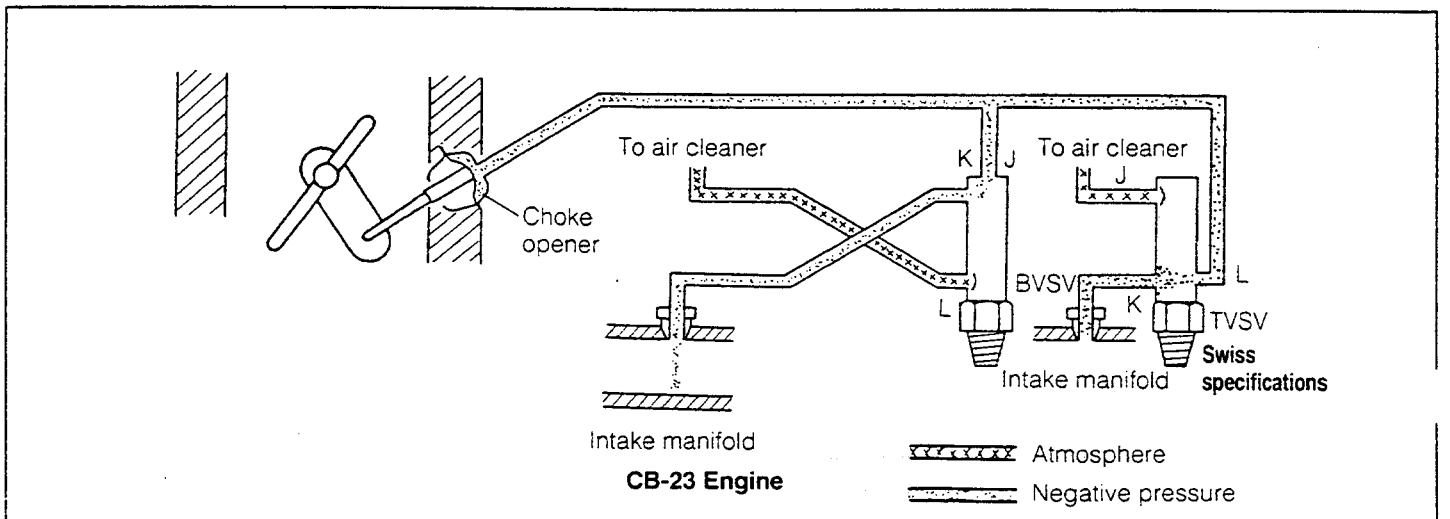

Fig. 12-23

WM-12025

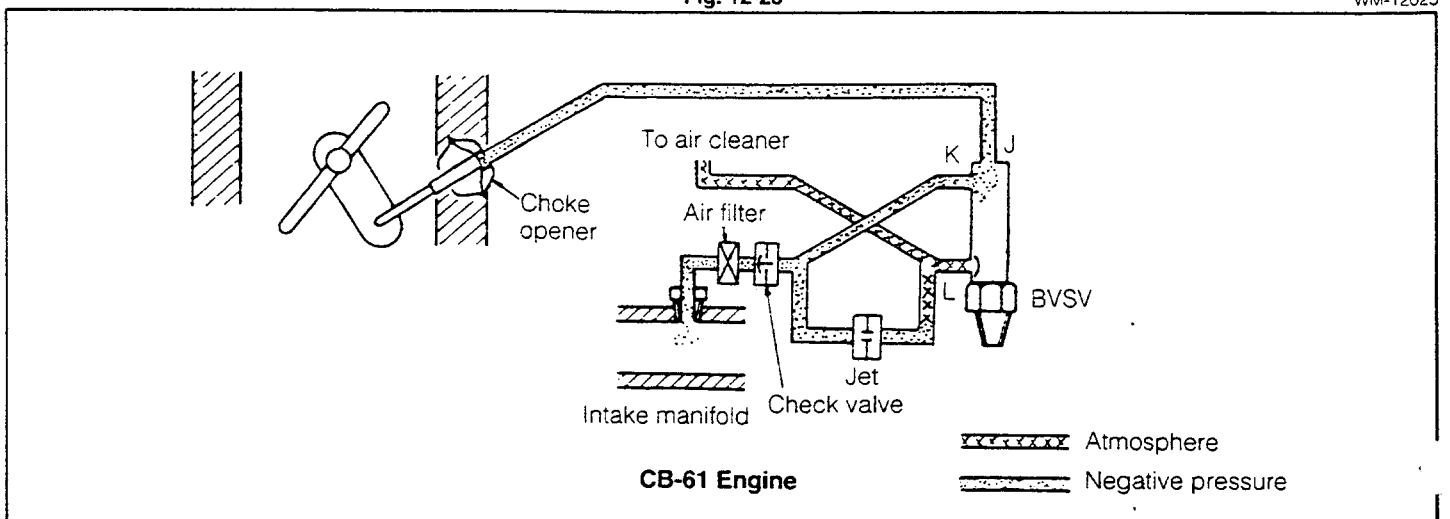

Fig. 12-24

WM-12026

SYSTEM CHECK

While the engine is running at the idle speed, disconnect the vacuum hose connected to the choke opener. If the link shows the following behaviors described in the table below, it represents a satisfactory operation.

Cooling water temperature	When hose is connected
10°C or below	Link will not move. (No vacuum is applied to hose.)
29°C or above	Link moves. (Vacuum is applied to hose.)

UNIT CHECK

- With a MityVac connected, apply a vacuum of 220 mm Hg to the choke opener. If the link is pulled, it represents a normal operation.
Next, release the vacuum. If the link returns quickly, it indicates a normal function.

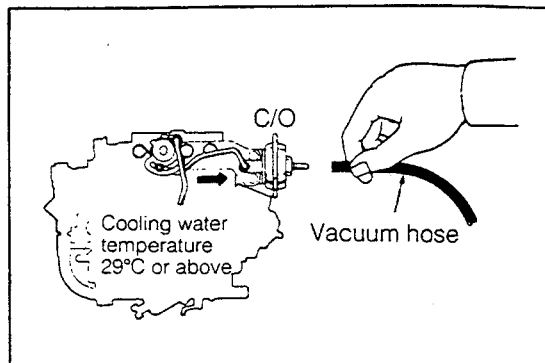

Fig. 12-25

WM-12027

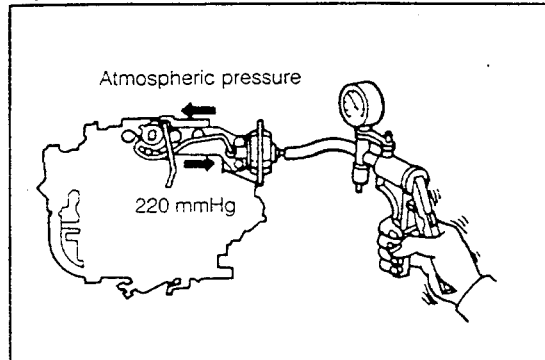

Fig. 12-26

WM-12028

2. BSV OR TVSV

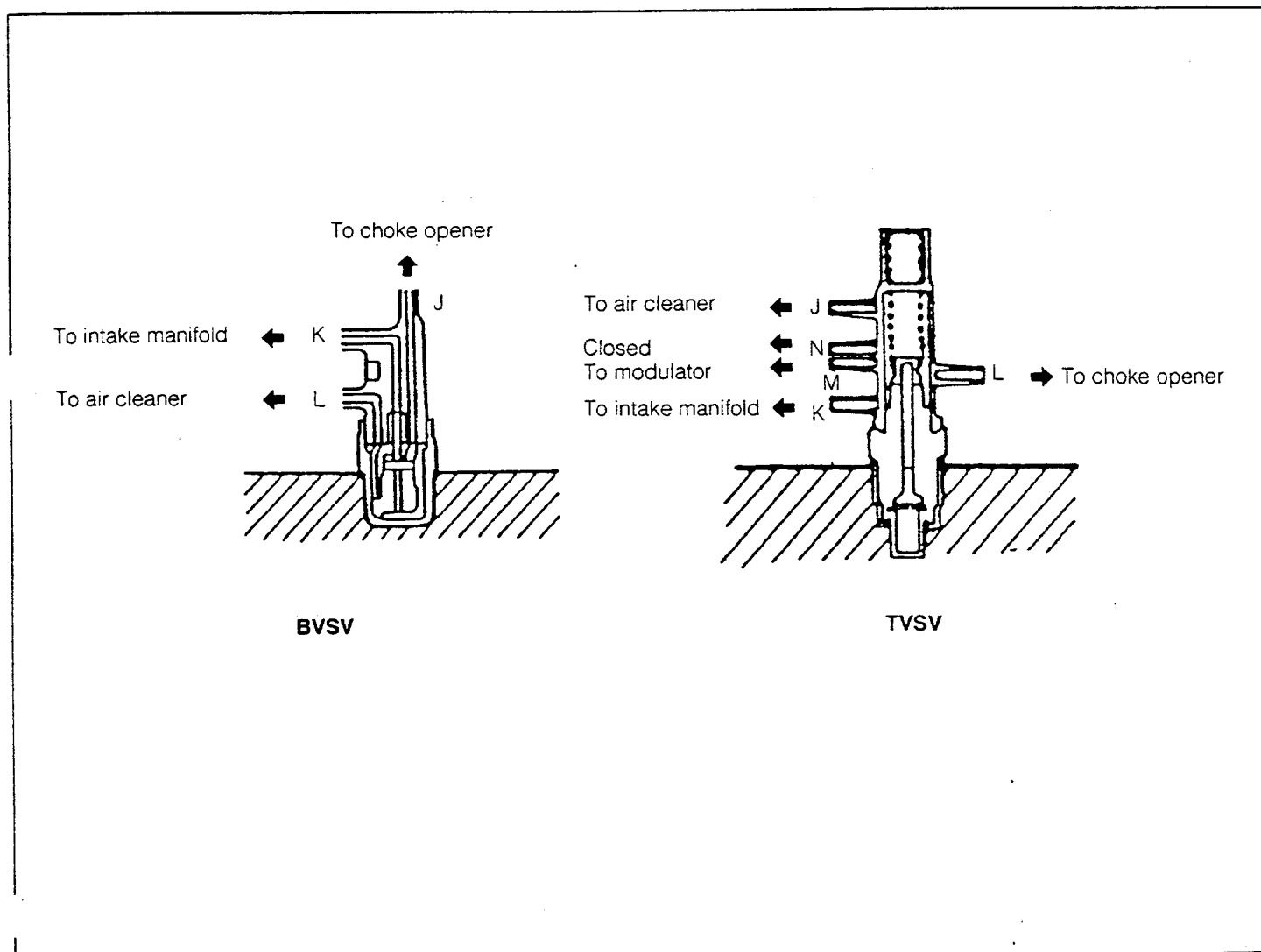

Fig. 12-27

WM-12029

EMISSION CONTROL SYSTEM

Gradually heat the BVSV or TVSV. Then, cool it gradually. Check the valve for air continuity during the check.

Test water temperature	Port	K	L	J
10°C (50°F) or below		○	○	○
30°C (86°F) or above		○	○	○

○—○ mark denote that vent continuity exists.

Test water temperature	J	N	M	L	K
0°C (34°F) or below	○	○	○	○	○
14°C (57°F) or above	○	○	○	○	○
46°C (115°F) or above	○	○	○	○	○
66°C (151°F) or above	○	○	○	○	○

○—○ mark denote that vent continuity exists.

DASHPOT SYSTEM

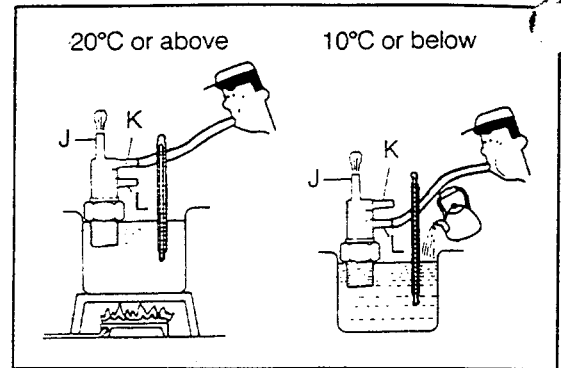

Fig. 12-28

WM-12030

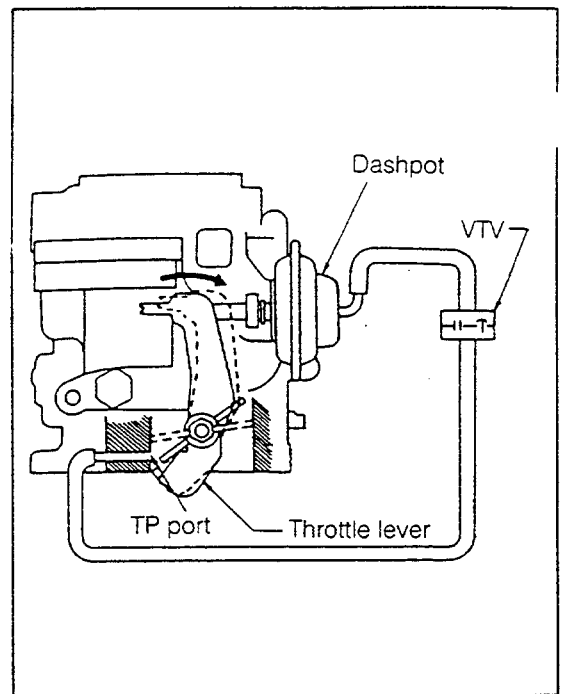

Fig. 12-29

WM-12031

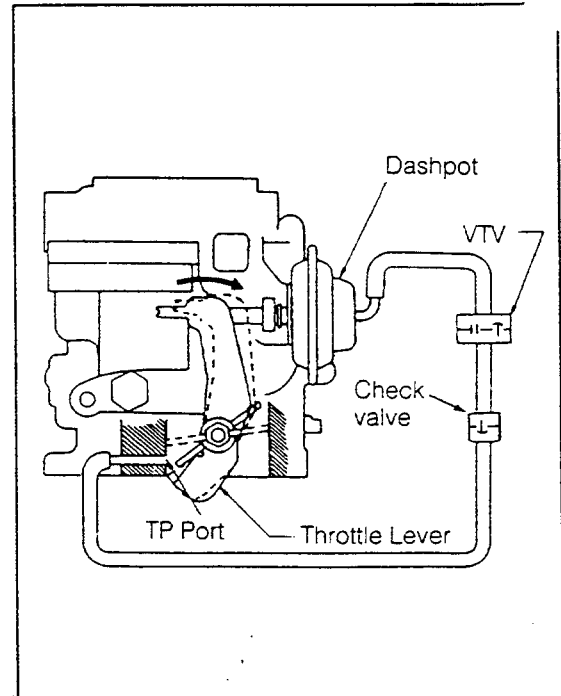

Fig. 12-30

WM-12032

STEM CHECK

1. Hold the engine revolution speed at 2500 rpm for a short period of time. Then, release the throttle.
2. While the engine revolution speed drops, measure the time required for the engine speed to drop from 1500 rpm to 1000 rpm.

If the required time falls within the range given below, the dashpot system is functioning properly.

Specified Time: 2.0 - 4.0 seconds

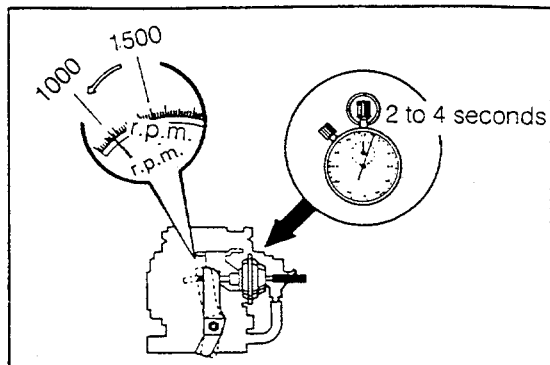

Fig. 12-31

WM-12033

UNIT CHECK

Dashpot

With a MityVac connected, apply a vacuum of 220 mm Hg to the dashpot. If the shaft is pulled out, it represents a normal operation.

Next, release the vacuum. If the shaft returns quickly, it indicates a normal function.

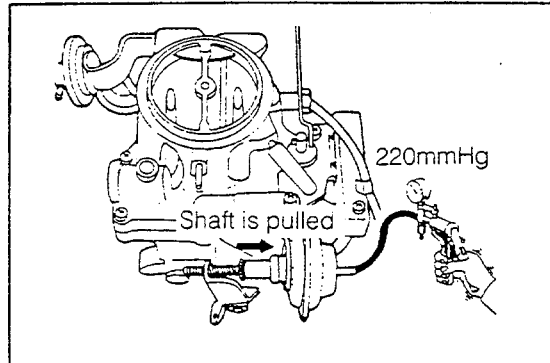

Fig. 12-32

WM-12034

FUEL EVAPORATIVE EMISSION CONTROL SYSTEM

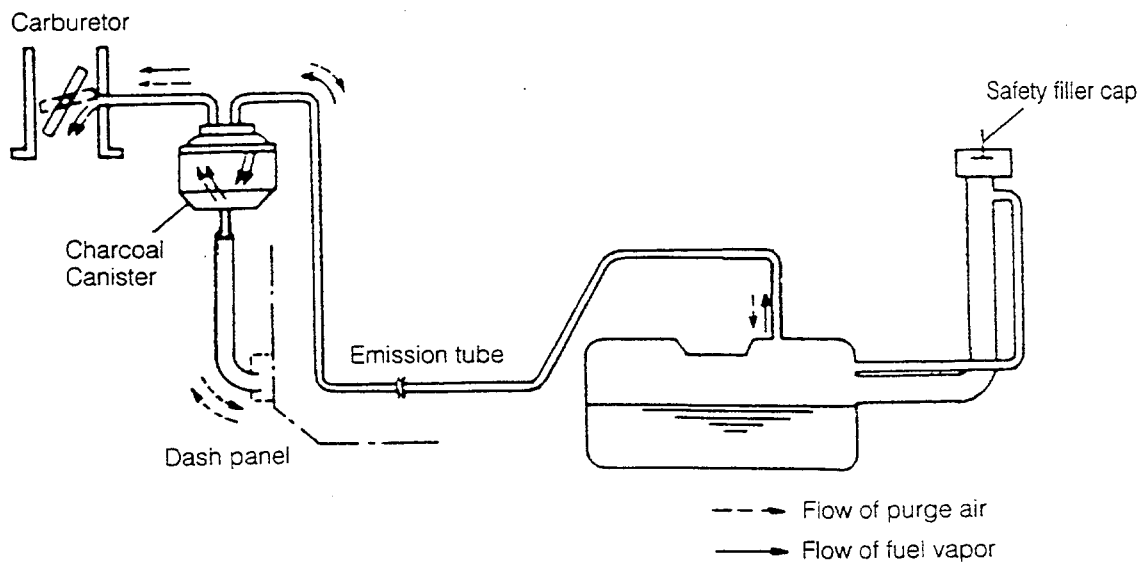

Fig. 12-33

WM-12035

EMISSION CONTROL SYSTEM

CHARCOAL CANISTER

CAUTION:

1. Handle the charcoal canister with utmost care, for most likely it has absorbed gasoline.
2. Never attempt to disassemble the charcoal canister. The charcoal canister has been so constructed that it is integral with the check valve.

WM-12036

INSPECTION

Check the charcoal canister for continuity between ports, as follows:

1. When you blow your breath into the canister through the port A (TO CARB), there should be no continuity. Also, when you blow your breath strongly into the canister through the port B (TO TANK), there should be continuity.
2. While blowing breath strongly into the canister through the port C, perform the continuity check of the check valves located at the ports A and B, following the procedure given below.
 - (1) When the port A is plugged with finger, air should emit from the port B.
 - (2) When the port B is plugged with finger, air should emit from the port A.

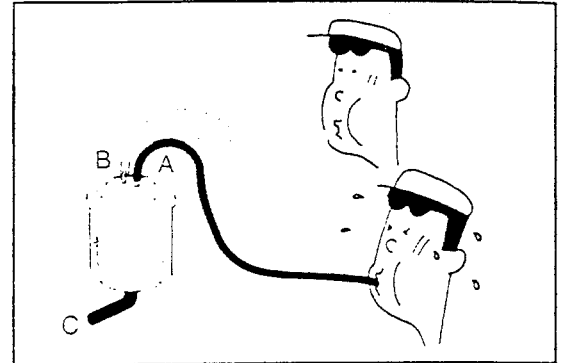

Fig. 12-34

WM-12037...

MAIN AIR BLEED

In order to maintain proper air-to-fuel ratio during heavy load operation, a VCV has been provided at the main air bleed No. 2.

When the turbocharging pressure exceeds 0.28 kg/cm^2 ($+210 \text{ mmHg}$), the VCV closes.

As a result, the air ceases flowing from the surge tank to the main air bleed No. 2.

VCV Specifications

Valve closing pressure	0.28 kg/cm^2 ($+210 \text{ mmHg}$) $(3.98 \text{ psi } (+210 \text{ mmHg}))$
------------------------	---

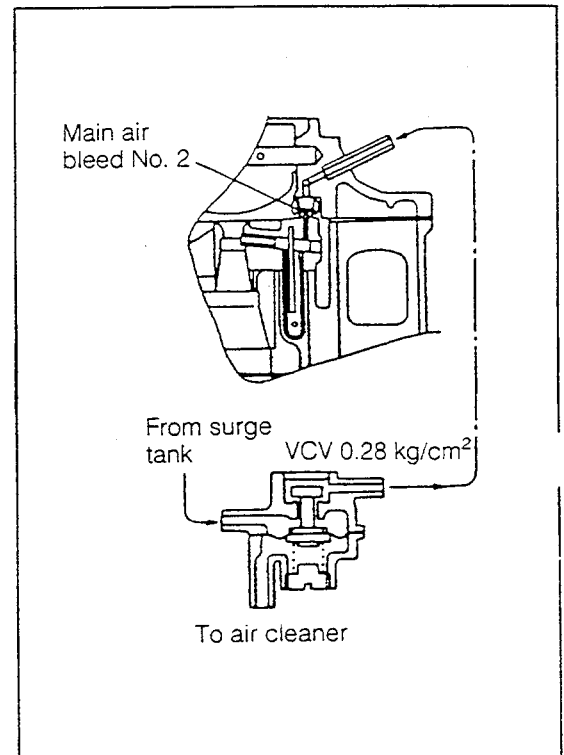
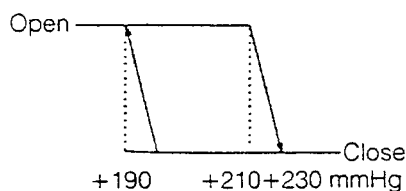

Fig. 12-35

WM-12038

VCV Characteristics



WM-12039

OPERATION CHECK OF VCV

1. If air continuity exists when you blow your breath from the side of A or B port, the VCV is satisfactory.
2. Plug the port A side and connect a turbocharger pressure gauge to the port B side. Then, apply a positive pressure of 0.5 kg/cm² (7.11 lb/inch²) and release the port A. If the pointer is stable at this time, the VCV is satisfactory.
3. Release the port A to reduce the positive pressure gradually. If the pointer suddenly drops from a pressure of about 0.25 kg/cm² (3.56 lb/inch²), it means that the VCV is functioning properly.

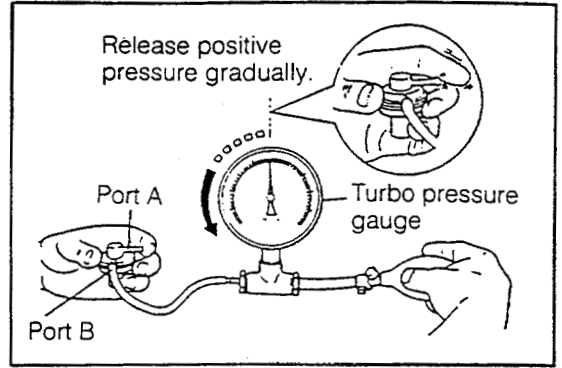

Fig. 12-36

WM-12040

SECONDARY AIR SUCTION SYSTEM (AS SYSTEM)

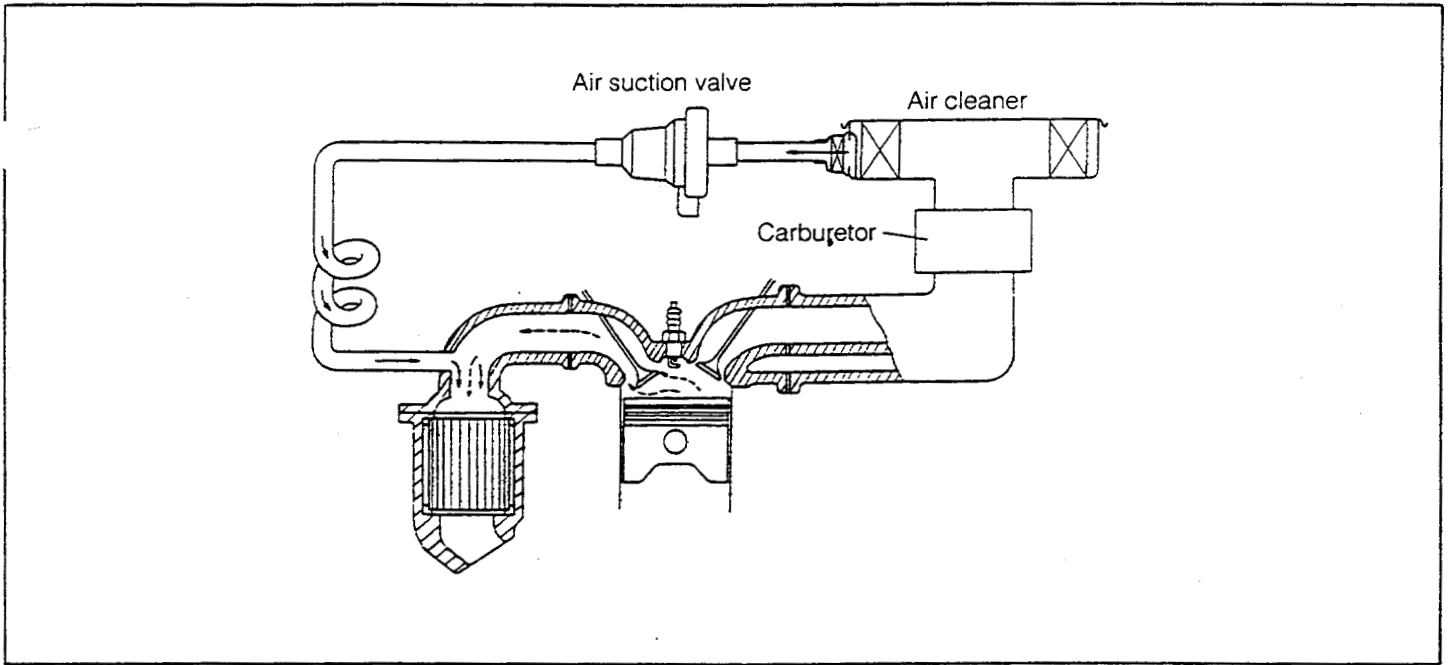

Fig. 12-37

WM-12041

CHECKING OF SECONDARY AIR SUCTION SYSTEM

1. Disconnect the hose between the air suction valve and the air cleaner.
2. Start the engine. If you can hear a pumping sound and the pumping sound ceases when you plug the hose with your hand, it indicates satisfactory operation.

NOTE:

Ensure that no exhaust gas blows back.

3. Make sure that the AS filter exhibits no restriction, contamination or damage.
4. Check air continuity of the air suction valve, as follows.
 - (1) Air continuity should exist when the section A is lightly blown.
 - (2) No air continuity should exist even when the section B is strongly blown.

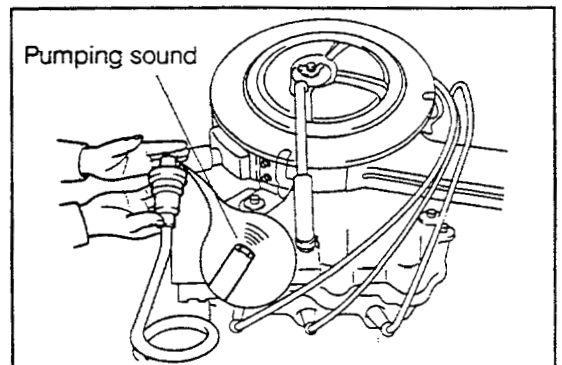

Fig. 12-38

WM-12042

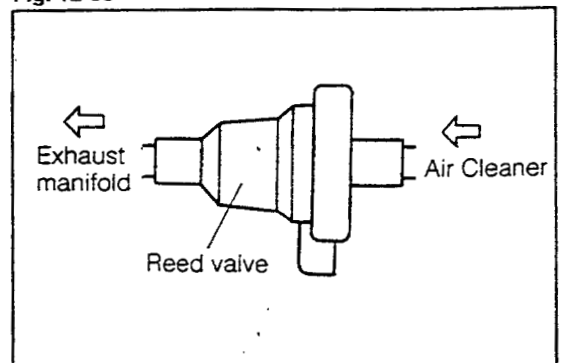

Fig. 12-39

WM-12043

ter engine is warmed-up:

(Temperature of cooling water is above 46.5°C):

1. Connect a vacuum gauge between the modulator valve and the EGR valve.
2. If the pointer of the vacuum gauge registers zero when the engine is started, it shows satisfactory operation.
3. Raise the engine revolution speed to approximately 3500 rpm. If the pointer of the vacuum gauge rises to around 150 mmHg, it indicates that the EGR system is functioning properly.
4. Connect a MityVac to the EGR valve.
5. Apply a negative pressure of 190 mmHg to the EGR valve, if the engine becomes roughly idling or stalls, it indicates that the EGR system is functioning properly.

UNIT INSPECTION

1. EGR valve

(1) Air-tightness check

Apply a negative pressure of 400 mmHg to the diaphragm chamber, using a MityVac. If the pointer is steady, it indicates that the EGR valve is satisfactory.

(2) Air-continuity check

If air continuity exists between the port A and the port B when a negative pressure of 190 mmHg or more is applied to the diaphragm chamber using a MityVac and if no air continuity exists between the port A and the port B when a negative pressure of 140 mmHg or less is applied to the diaphragm chamber, it indicates that the EGR valve is satisfactory.

2. Modulator

Plug either the port Q or the port P by your finger. Using a MityVac, apply a negative pressure to the remaining port. If the pointer returns to zero gradually, it indicates that the modulator is functioning properly.

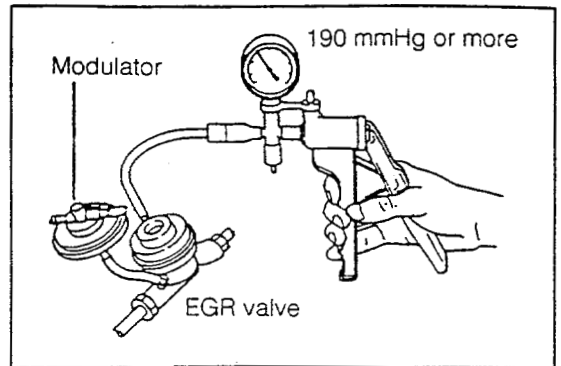

Fig. 12-43

WM-12047

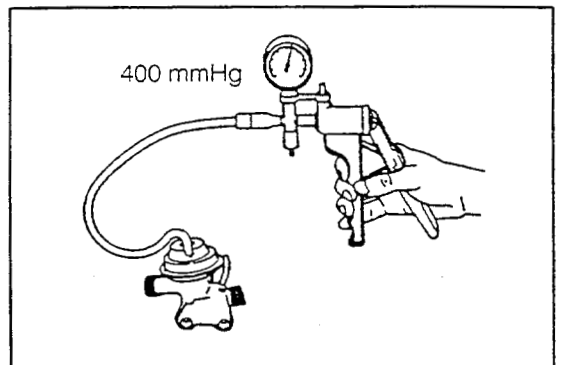

Fig. 12-44

WM-12048

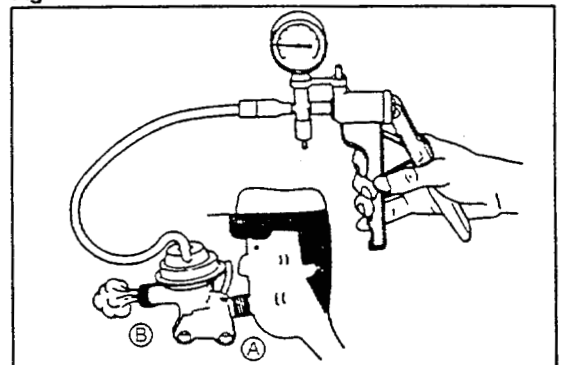

Fig. 12-45

WM-12049

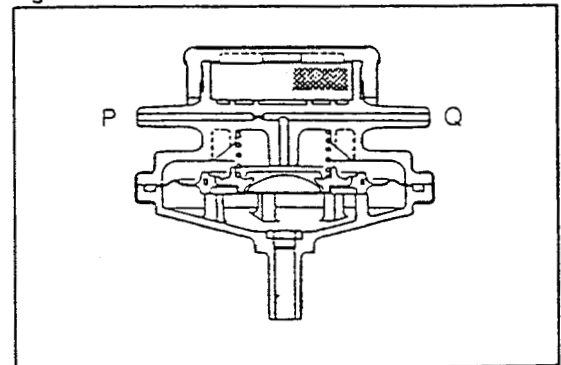

Fig. 12-46

WM-12050

EMISSION CONTROL SYSTEM

3. Check valve

If air continuity exists when your breath is blown from the port A and no air continuity exists when your breath is blown from the port B, it shows that the check valve is satisfactory.

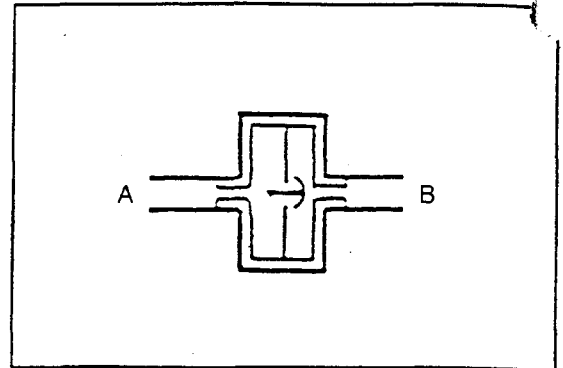

Fig. 12-47

WM-12051

CHOKE WARNING SYSTEM

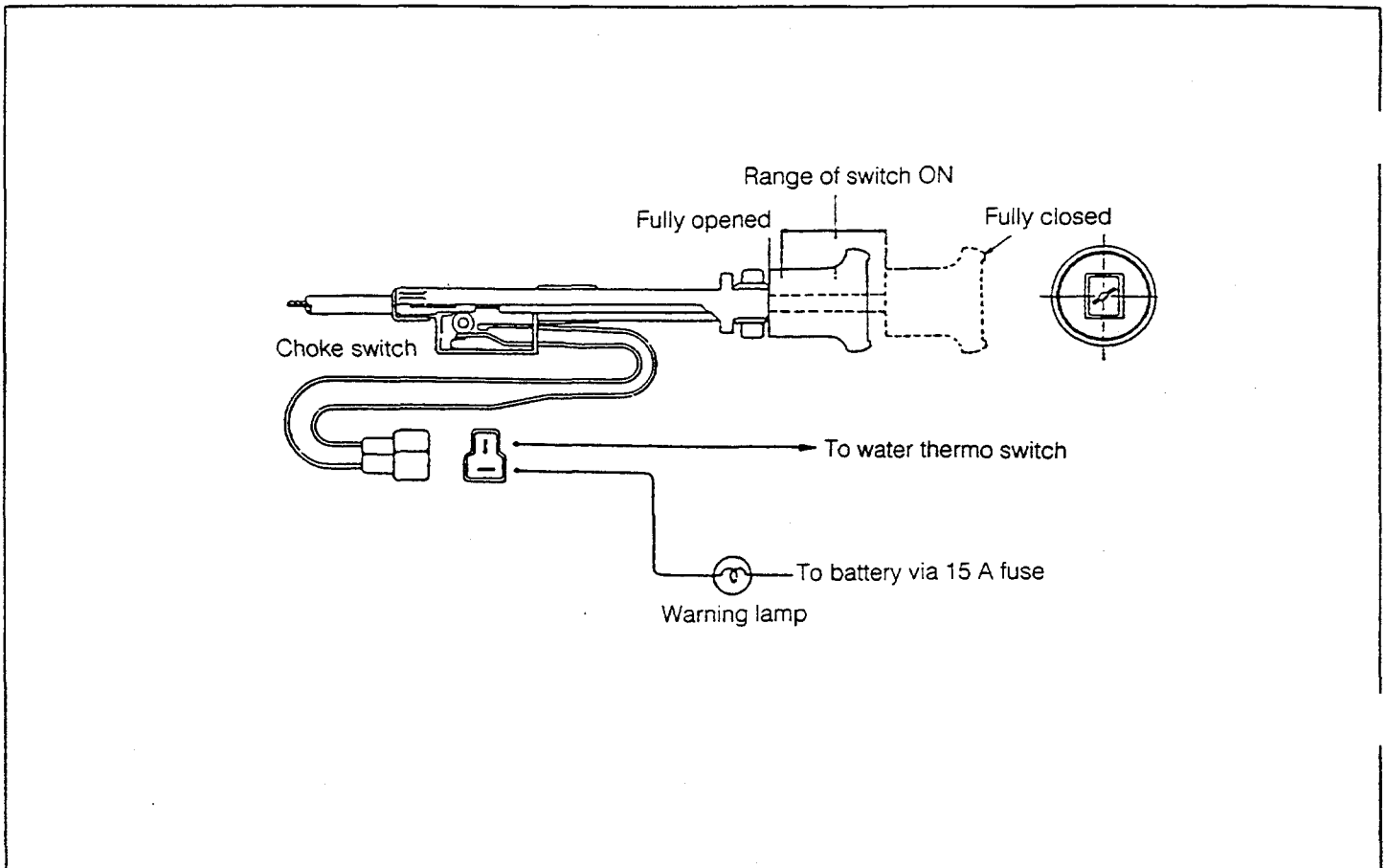

Fig. 12-48

WM-12052

CHECK

Choke Warning Lamp and Choke Switch

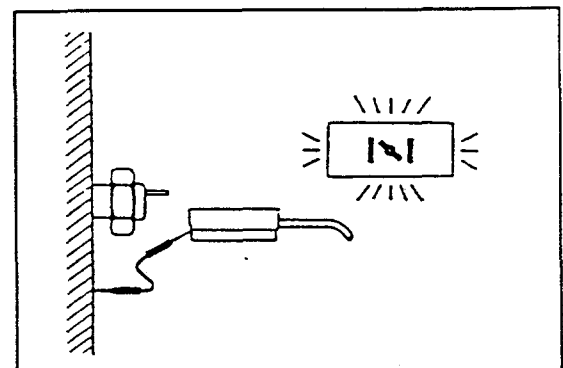
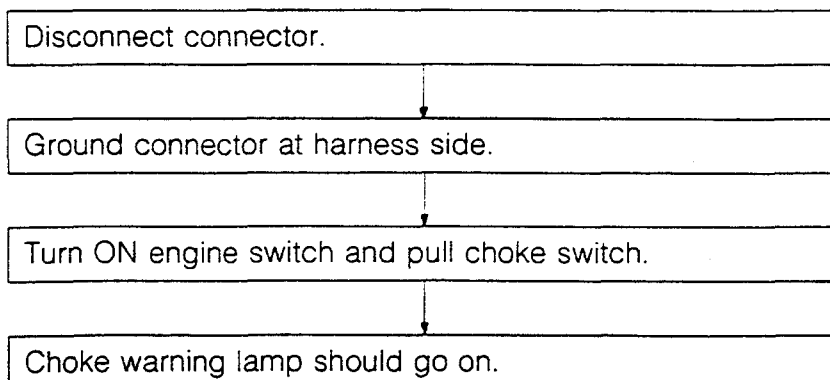

Fig. 12-49

WM-12053

Water Thermo Switch

- Disconnect connector.
- Disconnect connector.
- Ensure that no continuity exists between water thermo switch terminal and earth.
- Ensure that continuity exists between water thermo switch terminal and earth when water temperature exceed 70°C (45°F) after engine started.

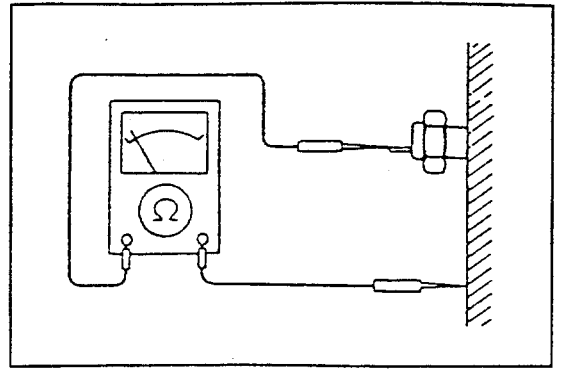

Fig. 12-50

WM-12054

FUEL CUT SYSTEM DURING DECELERATION

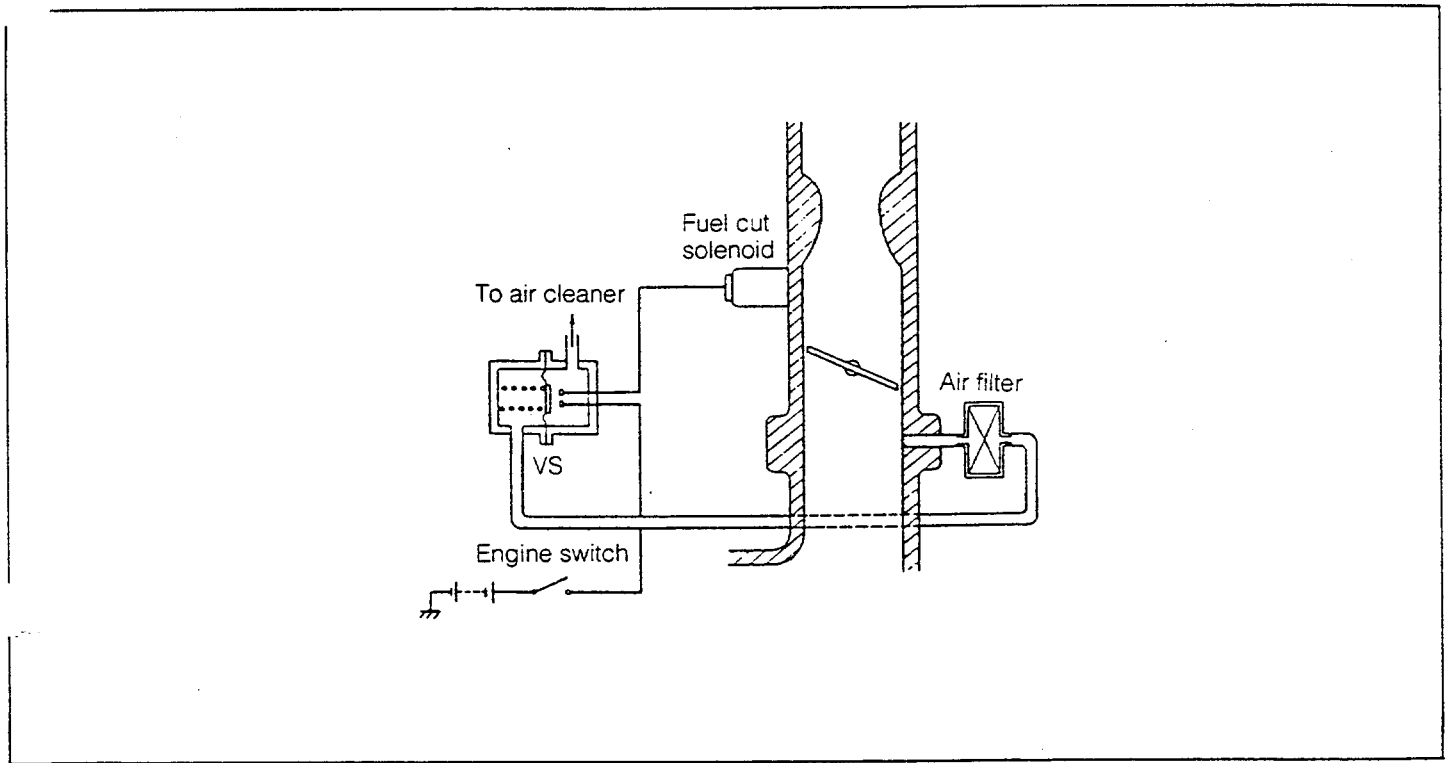

Fig. 12-51

WM-12055

When the intake manifold negative pressure exceeds the specified pressure, the vacuum switch is turned OFF and the fuel supply is cut.

OPERATING CONDITIONS OF SYSTEM

Operation Characteristic of Fuel Cut System During Deceleration

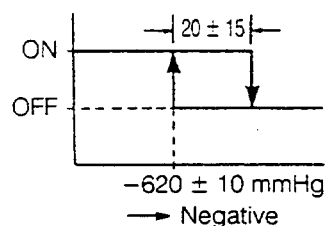

WM-12056

EMISSION CONTROL SYSTEM

SYSTEM CHECK

1. Connect a MityVac to the port S (CB23: Darkblue side, CB61: Skyblue side) of the vacuum switch. Plug the disconnected hose.
SST: 09258-00030-000
2. Set the engine revolution speed to 2000 rpm by means of the throttle adjusting screw.
3. Apply a negative pressure of at least 675 mmHg to the vacuum switch. If the engine revolution speed drops, it means that the system is functioning properly.
4. Open the port S of the vacuum switch to the atmosphere. If the engine revolution speed rises, it means that the system is functioning properly.

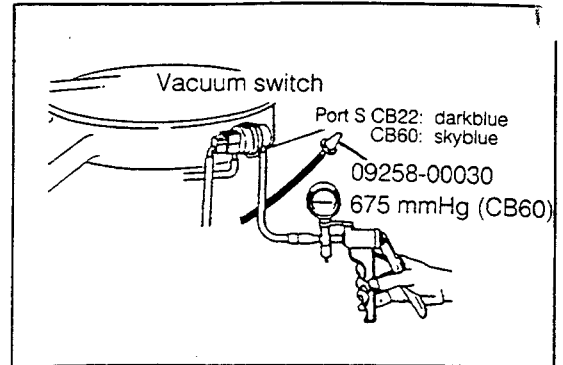

Fig. 12-52

WM-12057

UNIT CHECK

Solenoid Valve

1. Turn ON the engine switch.
2. Repeat the connection/disconnection of the solenoid valve connector. If you can hear a clicking sound or feel the operation with your hand placed on the solenoid valve, the solenoid valve is satisfactory.

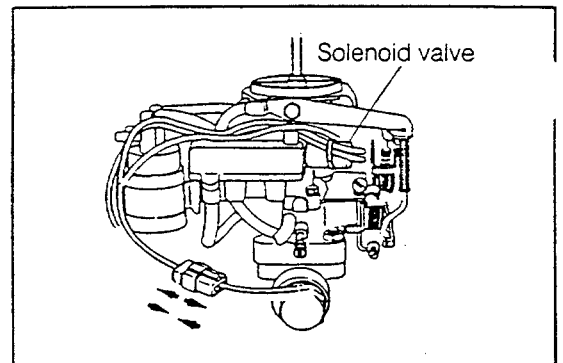

Fig. 12-53

WM-12058

VACUUM SWITCH

Continuity Check

600 mmHg or less

Between terminals: Continuity must exist.

675 mmHg or more

Between terminals: No continuity must exist.

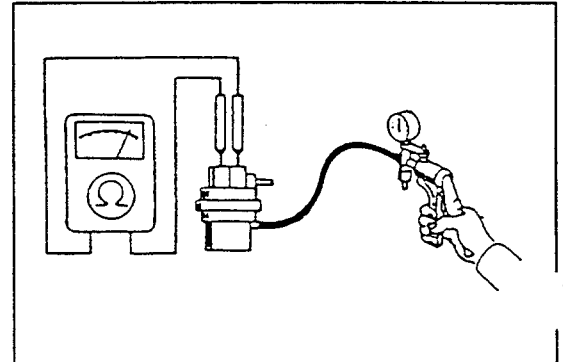

Fig. 12-54

WM-12059

UTER VENT SYSTEM

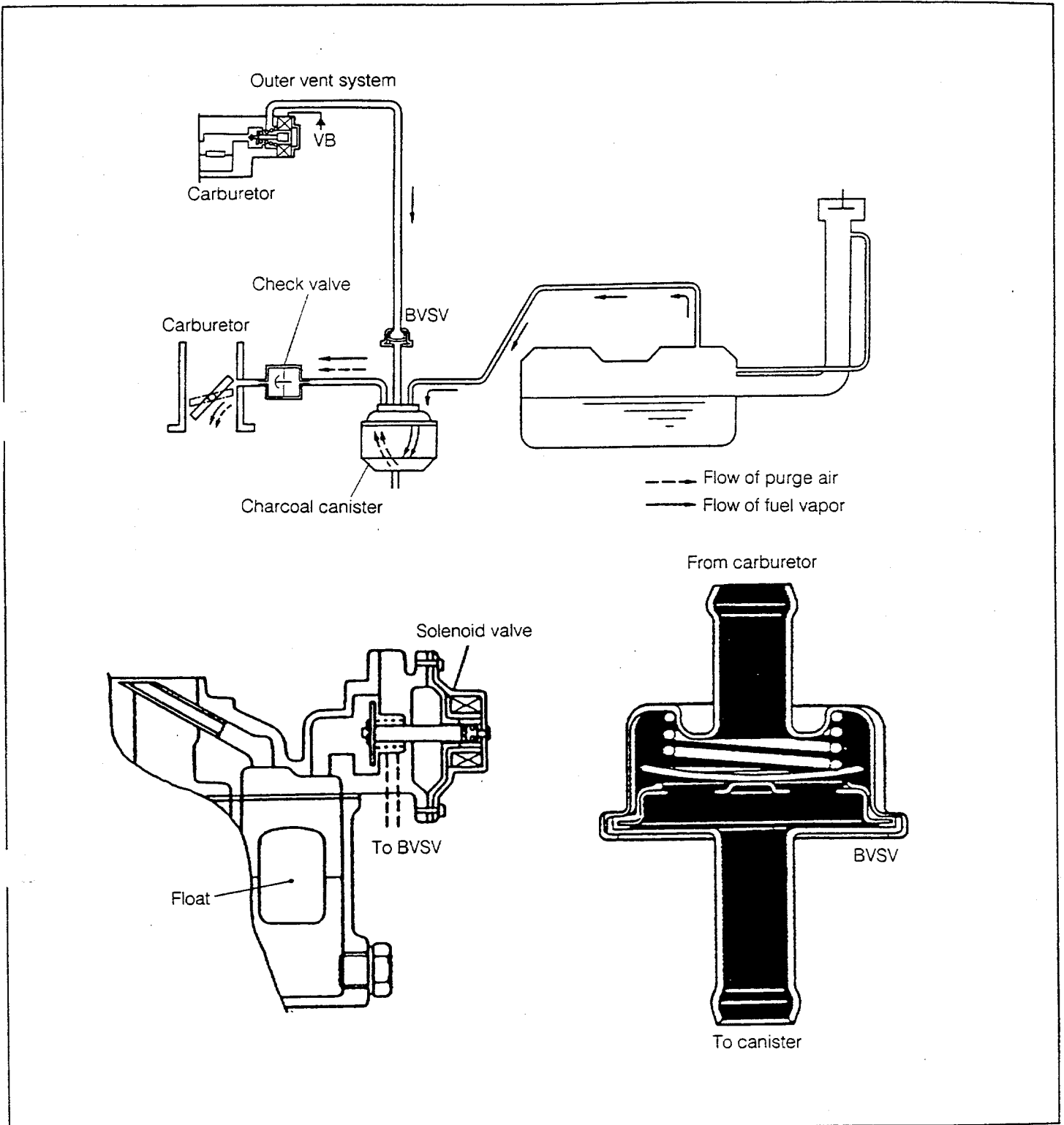

Fig. 12-55

WM-12060

This outer vent system has been adopted on all vehicles having Australian specifications. The system contributes to the reduction of HC emission.

Fuel evaporative emission which is emitted from the float chamber is sucked by means of the charcoal canister while the engine is stopped.

With the engine switch turned OFF, the outer vent opens the passage. As for the BVSV, it opens when the ambient temperature is above 60°C (140°F).

furthermore, this system has made it easier to restart the engine when the engine is hot.

WM-12061

EMISSION CONTROL SYSTEM

UNIT CHECK

BVSV

To check air continuity, blow your breath into the BVSV from the hose at the carburetor side.

Ambient Temperature

Below 40 °C..... No air continuity exists.

Above 60 °C..... Air continuity exists.

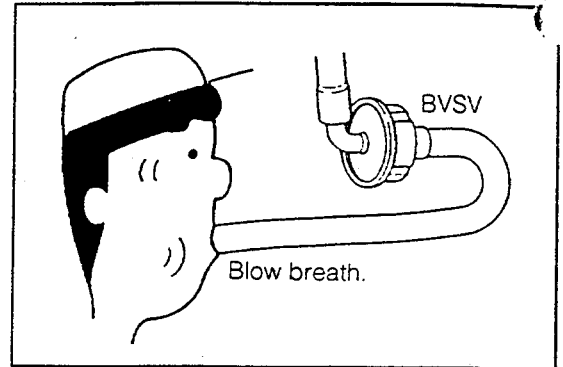

Fig. 12-56

WM-12062

Outer Vent Valve

With the engine switch turned ON, disconnect the hose of the BVSV at the carburetor. Blow your breath into the hose from the BVSV side. If no air continuity exists during the test above, but air continuity exists when the engine switch is turned OFF, it indicates a satisfactory operation.

Specified Value

Resistance between Terminals: 36 - 38 Ω

CAUTION:

Never attempt to suck the hose during the BVSV and outer vent valve checks, for most likely evaporative gasoline may remain in the hose.

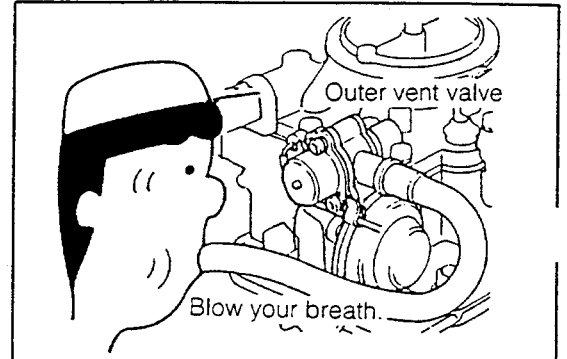

Fig. 12-57

WM-12063

Charcoal Canister

Check the charcoal canister for continuity between ports, as follows:

1. Plug the port ① by your finger.
2. When you blow your breath into the canister through the port ②, there should be no air continuity. Also, when you blow your breath strongly into the canister through the port ③, there should be air continuity.
3. While blowing your breath strongly into the canister through the port ④, perform continuity check of the check valve provided at the ports ⑤ and ⑥, following the procedure given below:
 - (1) When the port ⑤ is plugged by your finger, air should be discharged from the port ⑥.
 - (2) When the port ⑥ is plugged by your finger, air should be discharged from the port ⑤.
4. When you blow your breath strongly into the canister through the port ④, air should be discharged from the the port ④.

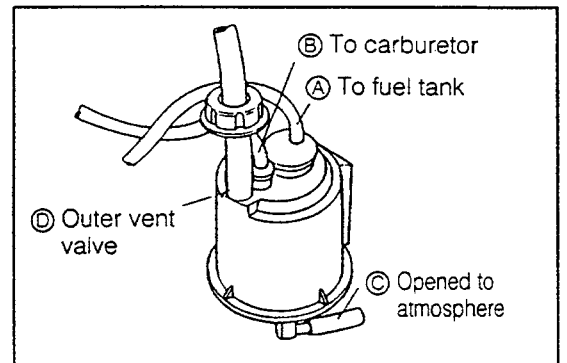

Fig. 12-58

WM-120

IGNITION TIMING CONTROL SYSTEM CHECK [CB-23 Engine]

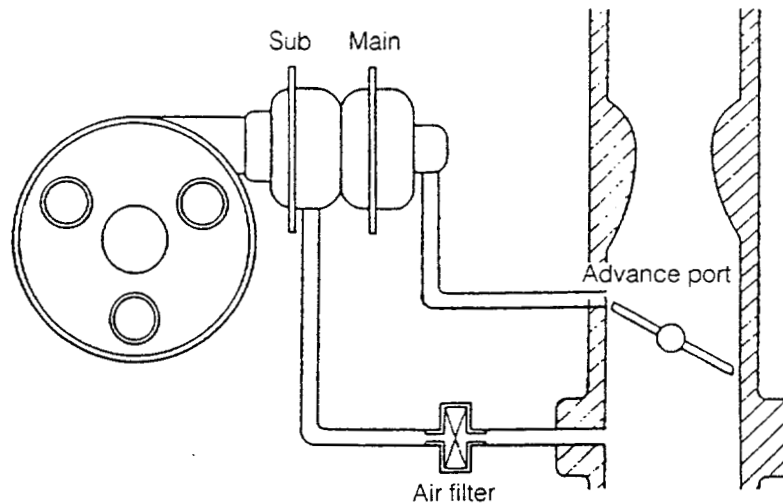

Fig. 12-59

WM-12065

MAIN SIDE

Connect a vacuum gauge between the main side of the distributor and the carburetor.

2. If the pointer of the vacuum gauge registers 150 mmHg or less during the idling, it means that the system is functioning properly.
3. Increase the engine speed gradually. If the negative pressure in proportion to the throttle opening is registered, it means that the system is functioning properly.

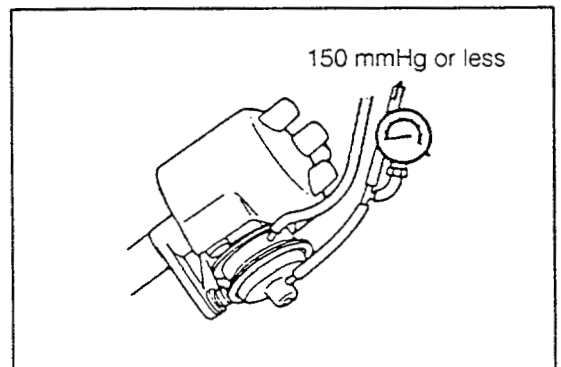

Fig. 12-60

WM-12066

SUB SIDE

1. Connect a vacuum gauge between the sub side of the distributor and the four-way joint.
2. If the vacuum gauge registers the manifold negative pressure (450 mmHg or more) during the idling operation, it means that the system is functioning properly.
3. Increase the engine speed gradually. If the negative pressure in proportion to the throttle opening is registered, it means that the system is functioning properly.

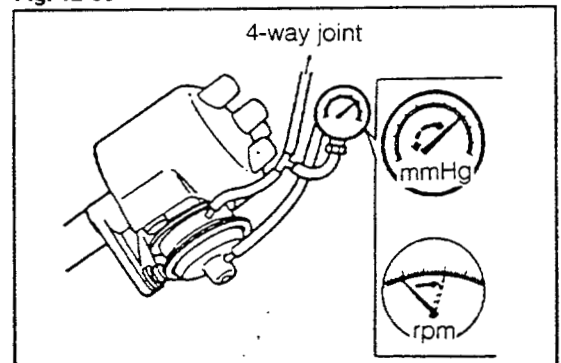

Fig. 12-61

WM-12067

EMISSION CONTROL SYSTEM

UNIT CHECK

Vacuum Controller

1. Operation Check
 - (1) Connect a MityVac to the main chamber or the sub chamber.
 - (2) If the breaker plate is sucked with the negative pressure applied, it means that the unit is satisfactory.
 - (3) If the breaker plate returns quickly with the negative pressure set to zero, it means that the unit is satisfactory.
2. Diaphragm Air-Tightness Check

If the pointer is stable when a negative pressure of 500 mmHg is applied, the unit is satisfactory.

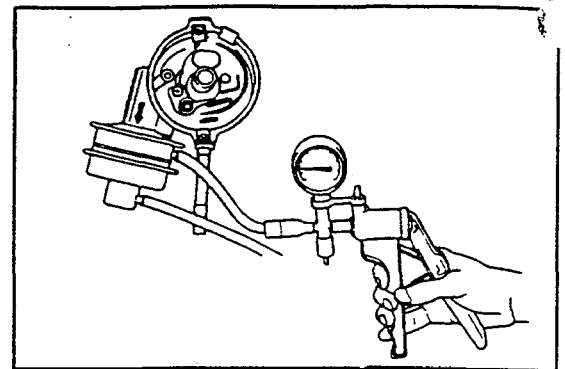

Fig. 12-62

WM-12068

Ignition timing check

1. Disconnect the vacuum hose at the sub side of the distributor. Then, plug the hose.
SST: 09258-00030-000
2. Check the ignition timing while the engine is idling, using a timing light.
Initial Ignition Timing: Manual transmission
 $5^{\circ} \pm 2^{\circ}/\text{BTDC}$ 800 ± 50 rpm
Manual transmission
 $5^{\circ} \pm 2^{\circ}/\text{BTDC}$ 850 ± 50 rpm
Automatic transmission

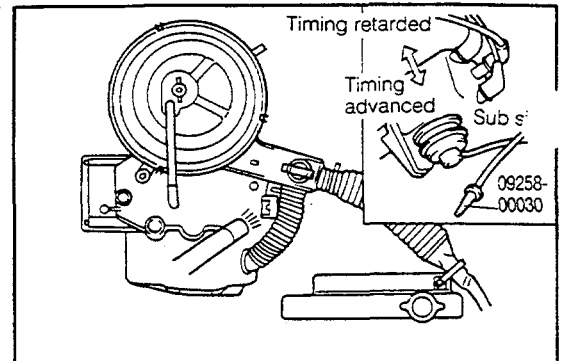

Fig. 12-63

WM-12069

IGNITION TIMING CONTROL SYSTEM [CB-61 Engine]

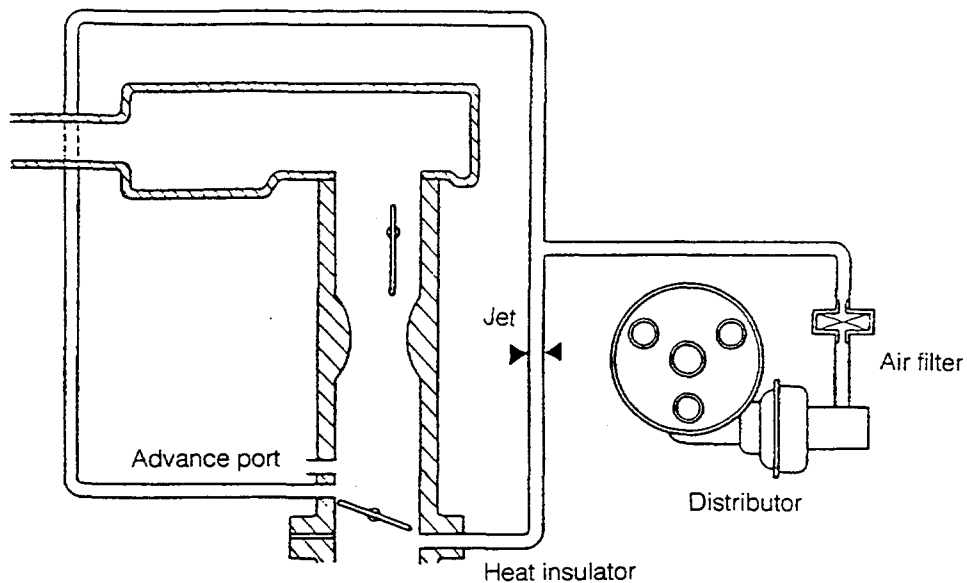

Fig. 12-64

WM-12070

IGNITION TIMING CONTROL SYSTEM CHECK

1. Connect a vacuum gauge between the vacuum controller of the distributor and the carburetor.
2. If the pointer of the vacuum gauge registers between -250 mmHg and -350 mmHg during the idling, it means that the system is functioning properly.
3. Increase the engine speed gradually. If the negative pressure in proportion to the throttle opening is registered, it means that the system is functioning properly.
4. Disconnect the hose of the vacuum controller and connect the turbocharger pressure gauge into place. Apply a positive pressure up to 0.5 kg/cm². If the ignition timing is retarded, it means that the system is functioning properly.

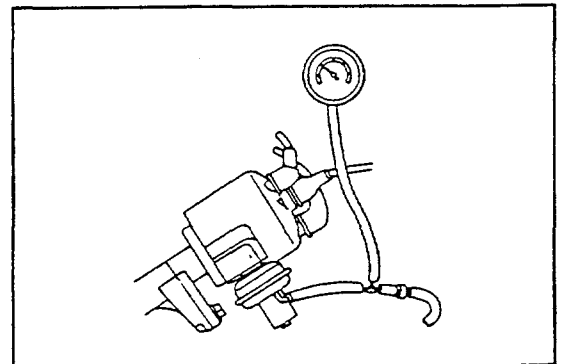

Fig. 12-65

WM-12071

EMISSION CONTROL SYSTEM

UNIT CHECK

1. Connect a MityVac or turbocharger pressure gauge to the vacuum controller and apply a negative pressure or positive pressure. If the breaker plate rotates, it means that the unit is functioning properly.
2. If the pointer is stable when a negative pressure of -500 mmHg is applied, it means that the air-tightness is satisfactory.

CHECK AND ADJUSTMENT OF IGNITION TIMING

1. Disconnect the vacuum hose of the vacuum controller of the distributor. Then, plug the hose.
SST: 09258-00030-000

2. Check the ignition timing during the idling operation, using a timing light.

Initial Ignition Timing:

Ignition timing

$10^{\circ} \pm 2^{\circ}$ /BTDC 800 ± 50 rpm

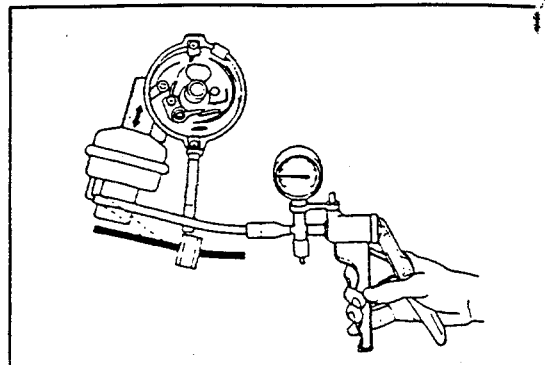
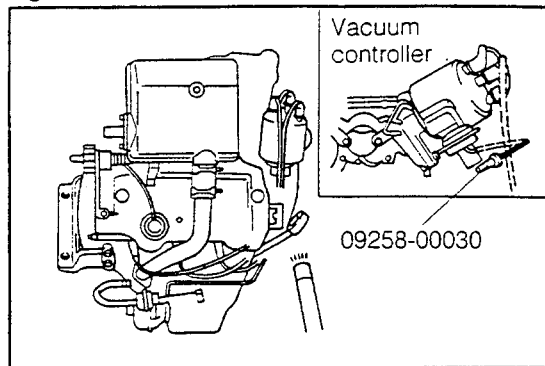

Fig. 12-66

WM-12072



WM-12073

DAIHATSU
TYPE CB
ENGINE

[CB-23, CB-61 & CB-80]

SECTION 13
APPENDIX











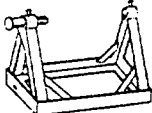

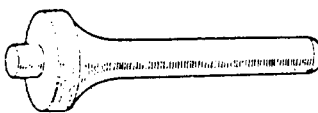
SST (Special Service Tools)	13- 2
SERVICE SPECIFICATIONS	13- 5
TIGHTENING TORQUE SPECIFICATIONS FOR MAIN PARTS	13-10

WM-13001





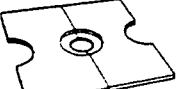



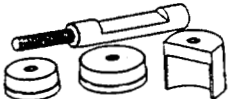
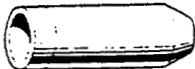

1

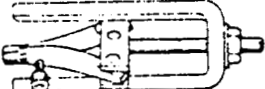
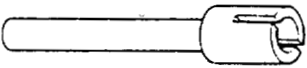
APPENDIX





SST (Special Service Tools)

Illustration	Tool No.	Tool Name
	09219-87202-000	Engine overhaul stand
	09219-87701-000	Engine overhaul attachment
	09210-87701-000	Flywheel holder
	09515-87202-000	Rear axle bearing inner replacer
	09219-87703-000	Cylinder head holder
	09202-87702-000	Valve spring replacer
	09201-87201-000	Valve guide remover & replacer
	09090-04810-000	Engine sling device
	09618-87301-000	Transmission bearing replacer
	09221-25018-000	Piston pin remover & replacer
	09217-87001-000	Piston replacing guide
	09253-87202-000	Water pump bearing anvil
	09214-87701-000	Balance shaft gear anvil

APPENDIX

Illustration	Tool No.	Tool Name
	09215-87701-000	Balance shaft gear bearing remover & replacer
	09506-87303-000	Differential drive pinion front bearing con replacer
	09608-87301-000	Axle hub & pinion bearing tool set
	09223-87702-000	Oil seal remover & replacer
	09204-87701-000	Valve rocker shaft puller
	09201-87703-000	Valve stem oil seal replacer
	09992-87704-000	Turbocharger pressure gauge
	09248-87703-000	Valve clearance tool
	09842-87704-000	EFI computer check subharness
	09842-30040-000	EFI inspection wire D
	09842-30050-000	EFI inspection wire A
	09258-00030-000	Hose plug set
	09243-00020-000	Idle adjusting wrench

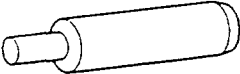
APPENDIX

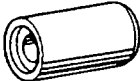
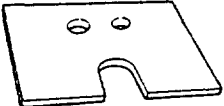
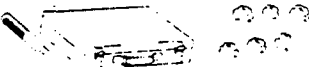
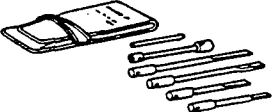
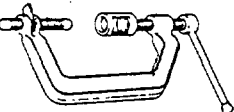
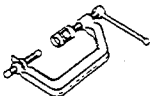
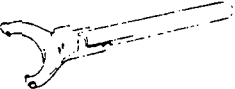
Illustration	Tool No.	Tool Name
	09268-87701-000	Fuel pressure gauge
	09286-46011-000	Injection camshaft bearing cone puller
	09285-76010-000	Injection camshaft bearing cone replacer
	09238-87201-000	Water pump bearing remover & replacer
	09237-87201-000	Water pump seal set remover & replacer
	09238-87701-000	Water pump rotor puller
	09254-87201-000	Water pump bearing receiver
	09608-12010-000	Front hub & drive pinion bearing replacer set
	09860-11011-000	Carburetor driver set
	09202-87002-0A0	Valve cotter attachment NOTE: Can be used as a set with 09202-87002-000
	09202-87002-000	Valve cotter remover & replacer
	09648-87201-000	Drive shaft replacer

SERVICE SPECIFICATIONS

CYLINDER HEAD

Item		CB-23 & CB-61 engines		CB-80 engine		Remarks
		Specified value	Allowable limit	Specified value	Allowable limit	
Cylinder head lower gasket surface distortion mm (inch)		—	0.10 (0.0039)	—	0.10 (0.0039)	On CB-23 engine only, recondition can be made, provided that head height limit of 125.7 mm (4.949 inches) is assured.
Manifold gasket surface distortion mm (inch)		—	0.10 (0.0039)	—	0.10 (0.0039)	Recondition can be made, provided that grinding limit of 0.3 mm (0.012 inch) is not exceeded.
Valve seat	Seat width mm (inch)	Intake	1.0 - 1.8 (0.039 - 0.071)	—	1.2 - 1.6 (0.047 - 0.063)	
		Exhaust	1.0 - 1.8 (0.039 - 0.071)	—	1.2 - 1.6 (0.047 - 0.063)	
	Seat angle	IN 30°-45°-70° EX 20°-45°-60°	—	20°-45°-70°	—	
	Valve seat recession allowable limit mm (inch)	—	IN 1.886 (0.0743) EX 2.807 (0.1105)	—	IN 4.23 (0.1665) EX 5.30 (0.2087)	
Clearance with valve lifter mm (inch)		—	—	0.015 - 0.046 (0.0006 - 0.0018)	0.07 (0.028)	If limit is exceeded, replace.

WM-13005

VALUE GUIDE BUSH

Item		CB-23 & CB-61 engines		CB-80 engine		Remarks
		Specified value	Allowable limit	Specified value	Allowable limit	
Bush bore diameter mm (inch)	Intake	7.000 - 7.015 (0.2755 - 0.2762)	—	6.010 - 6.025 (0.2366 - 0.2372)	—	
	Exhaust	7.000 - 7.015 (0.2755 - 0.2762)	—	6.010 - 6.025 (0.2366 - 0.2372)	—	
Valve stem-to-bush clearance mm (inch)	Intake	0.040 - 0.070 (0.00157 - 0.00275)	0.09 (0.00354)	0.025 - 0.060 (0.0009 - 0.0024)	0.08 (0.0031)	If clearance exceeds limit, replace valve guide bush and valve as a set.
	Exhaust	0.045 - 0.075 (0.0018 - 0.0029)	0.10 (0.0039)	0.030 - 0.065 (0.0012 - 0.0026)	0.09 (0.0035)	

WM-13006

APPENDIX

VALVES

Item		CB-23 & CB-61 engines		CB-80 engine		Remarks
		Specified value	Allowable limit	Specified value	Allowable limit	
Seat width	mm (inch)					
	Intake	1.0 - 1.8 (0.039 - 0.070)	—	1.2 - 1.6 (0.047 - 0.063)	—	
	Exhaust	1.0 - 1.8 (0.039 - 0.070)	—	1.2 - 1.6 (0.047 - 0.063)	—	
Overall length	mm (inch)					Recondition can be made provided that grinding limit of 0.8 mm (0.031 inch) is not exceeded.
	Intake	101.65 (4.0019)	100.85 (3.970)	107.0 (4.2126)	106.2 (4.1811)	
	Exhaust	101.65 (4.0019)	100.85 (3.970)	107.2 (4.2204)	106.4 (4.1890)	
Valve stem outer diameter	mm (inch)					
	Intake	6.945 - 6.960 (0.2734 - 0.2740)	—	5.970 - 5.985 (0.2350 - 0.2356)	—	
	Exhaust	6.940 - 6.955 (0.2732 - 0.2738)	—	5.960 - 5.980 (0.2346 - 0.2354)	—	
Valve head stock thickness	mm (inch)					If thickness becomes less than limit, replace valve.
	Intake	—	0.8 (0.031)	—	0.7 (0.028)	
	Exhaust	—	1.0 (0.039)	—	0.8 (0.031)	

WM-13007

VALVE SPRING

Item		CB-23 & CB-61 engines		CB-80 engine		Remarks
		Specified value	Allowable limit	Specified value	Allowable limit	
Out-of-squareness (under free state)	mm (inch)	—	1.5 (0.059)	—	1.5 (0.059)	If limit is exceeded, replace.
Free length	mm (inch)	43.3 (1.705)	42 (1.654)	45.9 (1.807)	44.5 (1.752)	If length becomes less than limit, replace.
Spring tension as installed	kg/mm (lb/inch)	25.7/34.9 (56.7/1.374)	22.7/34.9 (50.1/1.374)	40.4/27.67 (89.1/1.09)	34.4/27.67 (75.9/1.09)	If tension drops below limit, replace.

WM-13008

VALVE ROCKER SHAFT & ROCKER ARM [CB-23 & CB-61 Engines]

Item	CB-23 & CB-61 engines		Remarks
	Specified value	Allowable limit	
Rocker arm bore diameter	mm (inch)	16.000 - 16.018 (0.629 - 0.630)	16.06 (0.632) If bore exceeds limit, replace.
Rocker shaft outer diameter	mm (inch)	15.958 - 15.984 (0.628 - 0.629)	15.93 (0.627) If outer diameter becomes less than limit, replace.
Shaft-to-arm clearance	mm (inch)	0.016 - 0.060 (0.0006 - 0.0024)	0.09 (0.0035) If clearance exceeds limit, replace.

WM-13009

CYLINDER BLOCK

Item		CB-23 & CB-61 engines		CB-80 engine		Remarks
		Specified value	Allowable limit	Specified value	Allowable limit	
Top gasket surface distortion mm (inch)		—	0.1 (0.039)	—	0.1 (0.039)	On CB-23 engine only, recondition can be made, provided that block height limit of 200.55 mm (7.896 inches) is assured.
Cylinder bore	Cylinder-to-piston clearance mm (inch)	0.035 - 0.055 (0.0014 - 0.0022)	0.12 (0.0047)	0.045 - 0.065 (0.0018 - 0.0026)	0.12 (0.0047)	If limit is exceeded, recondition.
	Out-of roundness, taper mm (inch)	—	0.1 (0.039)	—	0.1 (0.039)	If limit is exceeded, recondition.

WM-13010

PISTON, PISTON PIN & PISTON RINGS

Item		CB-23 & CB-61 engines		CB-80 engine		Remarks	
		Specified value	Allowable limit	Specified value	Allowable limit		
Piston-to-cylinder clearance mm (inch)		0.035 - 0.055 (0.0014 - 0.0022)	0.12 (0.0047)	0.045 - 0.065 (0.0018 - 0.0026)	0.12 (0.0047)	If limit is exceeded, recondition.	
Piston ring	End gap mm (inch)	Compression No.1	0.20 - 0.40 (0.0078 - 0.0157)	0.7 (0.0276)	0.35 - 0.45 (0.0138 - 0.0177)	If limit is exceeded, replace rings as a set.	
		Compression No.2	0.20 - 0.35 (0.0078 - 0.0138)	0.7 (0.0276)	0.28 - 0.40 (0.0110 - 0.0157)		
		Oil ring	0.20 - 0.80 (0.0079 - 0.0315)	1.1 (0.0433)	0.20 - 0.70 (0.0079 - 0.00276)		1.1 (0.0433)
	Side Clearance mm (inch)	Compression No.2	0.03 - 0.07 (0.0012 - 0.0028)	0.12 (0.0047)	0.05 - 0.09 (0.0020 - 0.0035)	0.12 (0.0047)	If limit is exceeded, replace.
		Compression No.2	0.02 - 0.06 (0.0012 - 0.0024)	0.12 (0.047)	0.02 - 0.06 (0.0008 - 0.0024)	0.12 (0.047)	
		Oil ring (reference)	0.01 - 0.03 (0.0004 - 0.0012)	—	0.01 - 0.03 (0.0004 - 0.0012)	—	
Piston-to-piston pin oil clearance mm (inch)		—	0.030 (0.0012)	—	0.030 (0.0012)	If clearance exceeds limit, replace piston and piston pin as a set.	

WM-13011

CONNECTING ROD

Item		CB-23 & CB-61 engines		CB-80 engine		Remarks
		Specified value	Allowable limit	Specified value	Allowable limit	
Bearing oil clearance mm (inch)		0.020 - 0.044 (0.0008 - 0.0017)	0.07 (0.0028)	0.024 - 0.048 (0.0009 - 0.0019)	0.07 (0.0028)	
Big end thrust clearance mm (inch)		[CB-23] 0.15 - 0.25 (0.0059 - 0.0098) [CB-61] 0.15 - 0.33 (0.0059 - 0.0130)	[CB-23] 0.30 (0.0118) [CB-61] 0.38 (0.0149)	0.15 - 0.40 (0.0059 - 0.0157)	0.45 (0.0177)	
Allowable limit of connecting rod	Bend	—	0.05 (0.002)	—	0.05 (0.002)	If limit is exceeded, replace.
	Twist	—	0.05 (0.002)	—	0.05 (0.002)	

WM-13012

APPENDIX

CRANKSHAFT

Item	CB-23 & CB-61 engines		CB-80 engine		Remarks
	Specified value	Allowable limit	Specified value	Allowable limit	
Crankshaft runout mm (inch)	—	0.06 (0.024)	—	0.06 (0.024)	If runout exceeds limit, replace.
Out-of-roundness of main bearing and crankpin journals mm (inch)	—	0.01 (0.0004)	—	0.01 (0.0004)	If out-of-roundness exceeds limit, replace.
Main bearing journal outer diameter mm (inch)	41.976 - 42.000 (1.6526 - 1.6535)	—	47.976 - 48.000 (1.8888 - 1.8898)	—	
Crankpin journal outer diameter mm (inch)	39.976 - 40.000 (1.5739 - 1.5748)	—	42.976 - 43.000 (1.6920 - 1.6929)	—	
Main bearing journal oil clearance mm (inch)	0.020 - 0.044 (0.00079 - 0.00173)	0.07 (0.00276)	0.020 - 0.044 (0.00079 - 0.00173)	0.07 (0.00276)	If limit is exceeded, crankshaft can be reconditioned.
Thrust clearance mm (inch)	0.02 - 0.22 (0.00079 - 0.0087)	0.30 (0.0118)	0.02 - 0.22 (0.00079 - 0.0087)	0.30 (0.0118)	If clearance exceeds limit, replace thrust washer, as required.

WM-13014

BALANCE SHAFT

Item	CB-23 & CB-61 engines		CB-80 engine		Remarks
	Specified value	Allowable limit	Specified value	Allowable limit	
Thrust clearance mm (inch)	0.03 - 0.13 (0.0012 - 0.0051)	0.20 (0.0079)	0.03 - 0.13 (0.0012 - 0.0051)	0.20 (0.0079)	If clearance exceeds limit, replace thrust washer.
Bearing bore diameter mm (inch)	Front bearing	45.000 - 45.025 (1.772 - 1.773)	—	45.000 - 45.025 (1.772 - 1.773)	—
	Rear bearing	34.000 - 34.025 (1.339 - 1.340)	—	34.000 - 34.025 (1.339 - 1.340)	—
Shaft outer diameter mm (inch)	Front section	44.959 - 44.975 (1.770 - 1.771)	—	44.959 - 44.975 (1.770 - 1.771)	—
	Rear section	33.959 - 33.975 (1.337 - 1.338)	—	33.959 - 33.975 (1.337 - 1.338)	—
Oil clearance mm (inch)	0.025 - 0.066 (0.0010 - 0.0026)	0.1 (0.0039)	0.025 - 0.066 (0.0010 - 0.0026)	0.1 (0.0039)	If clearance exceeds limit, replace bearing.

WM-13014

FLYWHEEL

Item	CB-23 & CB-61 engines		CB-80 engine		Remarks
	Specified value	Allowable limit	Specified value	Allowable limit	
Flywheel runout limit mm (inch)	—	0.10 (0.0039)	—	0.10 (0.0039)	If runout exceeds limit, replace flywheel.

WM-13015

NIFOLD

Item		CB-23 & CB-61 engines		CB-80 engine		Remarks
		Specified value	Allowable limit	Specified value	Allowable limit	
Gasket surface warpage mm (inch)	Intake side	—	0.10 (0.0039)	—	0.10 (0.0039)	If warpage exceeds limit, recondition can be made, provided that grinding limit of 0.3 mm (0.012 inch) is not exceeded.
	Exhaust side	—	0.10 (0.0039)	—	0.10 (0.0039)	

WM-13016

CAMSHAFT

Item		CB-23 & CB-61 engines		CB-80 engine		Remarks
		Specified value	Allowable limit	Specified value	Allowable limit	
Cam lobe height mm (inch)	Intake side	[CB-23] 39.987 - 40.187 (1.574 - 1.582) [CB-61] 39.937 - 40.137 (1.572 - 1.580)	39.8 (1.567)	39.55 - 39.65 (1.557 - 1.561)	39.4 (1.551)	If lobe height becomes less than limit, replace camshaft.
	Exhaust side	[CB-23] 39.987 - 40.187 (1.574 - 1.582) [CB-61] 39.937 - 40.137 (1.572 - 1.580)	39.8 (1.567)	39.15 - 39.25 (1.541 - 1.545)	39.0 (1.535)	
Runout	mm (inch)	—	0.03 (0.0012)	—	0.03 (0.0012)	If runout exceeds limit, replace camshaft.
Oil clearance mm (inch)	Front section	0.04 - 0.09 (0.0016 - 0.0035)	0.14 (0.0055)	—	—	If clearance exceeds limit, replace camshaft or cylinder head.
	Center section	0.09 - 0.14 (0.0035 - 0.0055)	0.19 (0.0075)	—	—	
	Rear section	0.06 - 0.11 (0.0024 - 0.0043)	0.16 (0.0063)	—	—	
	No.1 - No.8	—	—	0.025 - 0.066 (0.0010 - 0.0026)	0.16 (0.0063)	
Clearance in axial direction	mm (inch)	—	—	—	0.20 (0.0078)	If clearance exceeds limit, replace camshaft.

WM-13017

TIMING BELT PULLEY

Item		CB-23 & CB-61 engines		CB-80 engine		Remarks
		Specified value	Allowable limit	Specified value	Allowable limit	
Camshaft timing pulley outer diameter	mm (inch)	119.86 - 120.40 (4.7189 - 4.7401)	119.8 (4.7165)	110.637 - 110.757 (4.3558 - 4.3605)	110.6 (4.3543)	If diameter becomes less than limit, replace pulley.
Crankshaft timing pulley outer diameter	mm (inch)	59.26 (2.3331)	59.2 (2.3307)	54.651 - 54.751 (2.1516 - 2.1555)	54.6 (2.1496)	

WM-13018

APPENDIX







TIGHTENING TORQUE SPECIFICATIONS FOR MAIN COMPONENTS

1. When you want to find out suitable tightening torque for a bolt, first determine the strength division of the said bolt, using the table below. Then, locate suitable tightening torque in the tightening torque table described in the following pages.
2. As for the tightening torque for a nut, find out suitable tightening torque in the same way as with Paragraph 1 above, based on the mating bolt.
3. Tightening torque specifications posted in the workshop manual are standard values for steel fasteners. It is, therefore, necessary to modify these tightening torque specifications when you tighten fasteners made of materials other than steel. This rule also applies to such instances where bolts are undergoing heat or other stress, such as vibratory loads and so forth.

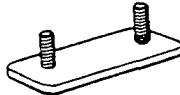
WM-13019

METHOD TO IDENTIFY STRENGTH DIVISION OF BOLTS

1. Identification Method by Checking Bolts Themselves

	Configuration and how to determine strength division	Strength division		Configuration and how to determine strength division	Strength division	
Hexagon bolt	 Bolt having an embossed or stamped figure at its head section	4 = 4T 5 = 5T 6 = 6T 7 = 7T	Welded bolt		4T	
	 No mark	4T		 No mark	4T	
	 Bolt having two embossed lines at its head section	5T 6T	Stud bolt		Bolt having about 2 mm deep recess at one end or both ends	6T
	 Bolt having three embossed lines at its head section	7T				

WM-17

2. Identification Method by Part Numbers

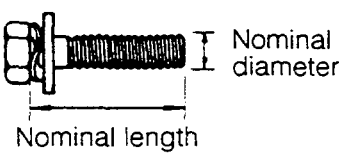
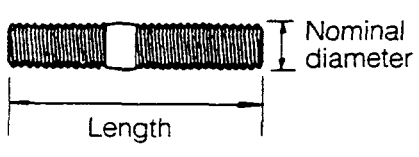
<p>Hexagon Bolt</p> <p>Part number example 9 1 1 1 1 - 4 0 6 2 0</p> <p>Nominal length (mm) → 06</p> <p>Nominal diameter (mm) → 20</p> <p>Strength division → 4</p> 	<p>Stud Bolt</p> <p>Part number example 9 2 1 3 2 - 4 0 6 2 0</p> <p>Nominal length (mm) → 06</p> <p>Nominal diameter (mm) → 20</p> <p>Strength division → 4</p> 
--	---

WM-13021

Tightening Torque Table for General Standard Bolts

Category	Nominal diameter	Pitch	Standard tightening torque kg-m (ft-lb)	
			Standard torque	Tightening range
4T (Bolt having a mark of "4" at its head section) Example of part number (91○○○ - 4○○○○)	6	1	0.47 (3.4)	0.4 - 0.7 (2.9 - 5.1)
	8	1.25	1.11 (8.0)	1.0 - 1.6 (7.2 - 11.6)
	10	1.25	2.25 (16.3)	1.9 - 3.1 (14 - 22.5)
	10	1.5	2.14 (15.5)	1.8 - 3.0 (13 - 22)
	12	1.25 (ISO)	4.40 (31.8)	3.5 - 5.5 (25 - 40)
	12	1.5	3.89 (28.1)	3.5 - 5.5 (25 - 40)
	12	1.75	3.74 (27.1)	3.0 - 5.0 (22 - 36)
	13	1.5	5.08 (36.7)	4.5 - 7.0 (33 - 51)
	14	1.5	6.33 (45.8)	5.0 - 8.0 (36 - 58)
	14	2	5.93 (42.9)	4.7 - 7.7 (34 - 56)
5T (Bolt having a mark of "5" at its head section) Example of part number (91○○○ - 5○○○○)	6	1	0.71 (5.1)	0.6 - 0.9 (4.3 - 6.5)
	8	1.25	1.66 (12.0)	1.5 - 2.2 (11 - 16)
	10	1.25	3.37 (24.4)	3.0 - 4.5 (22 - 33)
	10	1.5	3.20 (23.1)	2.7 - 4.2 (19.5 - 30.5)
	12	1.25 (ISO)	5.84 (42.2)	5.0 - 7.0 (36 - 51)
	12	1.5	5.84 (42.2)	5.0 - 7.0 (36 - 51)
	12	1.75	5.60 (40.5)	4.8 - 6.8 (34 - 49)
	13	1.5	7.63 (55.2)	6.5 - 9.0 (47 - 65)
	14	1.5	9.50 (68.7)	7.5 - 11.0 (54 - 79.5)
	14	2	8.90 (64.4)	7.0 - 10.5 (51 - 76)
6T (Bolt having a mark of "6" at its head section) Example of part number (91○○○ - 6○○○○)	6	1	0.71 (5.1)	0.6 - 0.9 (4.3 - 6.5)
	8	1.25	1.66 (12.0)	1.5 - 2.2 (11 - 16)
	10	1.25	3.37 (24.4)	3.0 - 4.5 (22 - 33)
	10	1.5	3.20 (23.1)	2.7 - 4.2 (19.5 - 30.5)
	12	1.25 (ISO)	5.84 (42.2)	5.0 - 7.0 (36 - 51)
	12	1.5	5.84 (42.2)	5.0 - 7.0 (36 - 51)
7T (Bolt having a mark of "7" at its head section) Example of part number (91○○○ - 7○○○○)	6	1	0.95 (6.87)	0.8 - 1.2 (5.8 - 8.7)
	8	1.25	2.20 (15.9)	2.0 - 3.0 (14.5 - 22)
	10	1.25	4.50 (32.5)	4.0 - 5.5 (29 - 40)
	10	1.5	4.30 (31.1)	3.7 - 5.2 (27 - 38)
	12	1.25 (ISO)	7.78 (56.3)	7.0 - 9.0 (51 - 65)
	12	1.5	7.78 (56.3)	7.0 - 9.0 (51 - 65)
	12	1.75	7.48 (54.1)	6.0 - 8.5 (43 - 61.5)
	13	1.5	10.17 (73.6)	8.0 - 12.0 (58 - 88)
	14	1.5	12.67 (91.6)	10.0 - 15.0 (72 - 108)
	14	2	11.86 (85.8)	9.5 - 14.0 (69 - 101)
16	1.5	19.15 (138.5)	15.0 - 23.0 (108 - 166)	
	2	18.11 (131.0)	14.9 - 22.0 (108 - 159)	

WM-13022

APPENDIX

Unit: kg-m (ft)

Tightening component	Tightening torque	
	CB-23 & CB-61 engines	CB-80 engine
Cylinder block × Cylinder head	5.5 - 6.5 (40 - 47)	6.0 - 7.0 (43 - 51)
Cylinder block × Crankshaft bearing cap	5.4 - 6.6 (40 - 48)	6.4 - 7.6 (46 - 55)
Spark plug × Cylinder head	1.5 - 2.2 (11 - 16)	1.5 - 2.2 (11 - 16)
Flyweel × Crankshaft	4.0 - 5.0 (29 - 36)	6.0 - 7.0 (43 - 51)
Crankshaft pulley × Crankshaft	9.0 - 10.0 (65 - 72)	9.0 - 10.0 (65 - 72)
Connecting rod × Connecting rod cap	2.1 - 2.9 (15 - 21)	4.2 - 5.2 (30 - 38)
Balance shaft thrust plate × Cylinder block	1.0 - 1.5 (7 - 11)	1.0 - 1.5 (7 - 11)
Cylinder head cover × Cylinder head	0.8 - 1.2 (6 - 9)	0.3 - 0.5 (2 - 4)
Fuel pipe × Carburetor	1.5 - 2.0 (11 - 14)	—
Oil pan drain plug × Oil pan	2.5 - 3.5 (18 - 25)	2.5 - 3.5 (18 - 25)
Fuel pump drive cam × Camshaft (CB-23 engine only)	1.0 - 1.5 (7 - 11)	—
Timing belt cover × Balance shaft gear cover	0.2 - 0.4 (1.4 - 3.0)	0.2 - 0.4 (1.4 - 3.0)
Fuel pipe × Fuel pump (CB-23 engine only)	1.5 - 2.2 (11 - 16)	—
Oil cooler × Oil filter bracket	3.0 - 4.0 (22 - 29)	3.0 - 4.0 (22 - 29)
Camshaft bearing cap × Cylinder head	—	1.15 - 1.45 (8.3 - 10.5)
Camshaft timing belt pulley × Camshaft	3.0 - 4.5 (22 - 32)	3.0 - 4.5 (22 - 32)
Timing belt idler No.2 × Cylinder head	—	4.0 - 5.0 (29 - 36)
Cylinder block × Oil pan	0.4 - 0.7 (3.0 - 5.0)	0.4 - 0.7 (3.0 - 5.0)
Valve adjusting screw × Lock nut	1.3 - 1.8 (9 - 13)	—
Exhaust manifold case No.1 × Exhaust manifold case No.2	2.0 - 3.0 (14 - 22)	2.0 - 3.0 (14 - 22)
Turbocharger × Exhaust manifold	2.5 - 3.3 (18 - 24)	2.5 - 3.3 (18 - 24)
Turbocharger × Exhaust manifold case No.1	3.0 - 4.0 (22 - 29)	2.5 - 3.3 (18 - 24)
Turbo oil inlet pipe S/A × Turbocharger	1.0 - 1.6 (7 - 12)	1.0 - 1.6 (7 - 12)
Cylinder head × Exhaust manifold	1.0 - 1.6 (7 - 12)	4.0 - 5.0 (29 - 36)
Cylinder head × Intake manifold	1.0 - 1.6 (7 - 12)	1.7 - 2.5 (12 - 18)
Intake manifold × Surge tank	—	3.5 - 4.5 (25 - 33)
Oil nozzle Ay × Oil pump Ay	—	3.0 - 3.5 (22 - 25)
Carburetor × Surge tank stud bolt (CB-61 engine only)	0.8 - 1.2 (6 - 9)	—
Carburetor × Surge tank cap nut (CB-61 engine only)	0.8 - 1.0 (6 - 7)	—

WM-13023

APPENDIX

Unit: kg-m (ft-lb)

Tightening component	Tightening torque	
	CB-23 & CB-61 engines	CB-80 engine
EGR pipe No.1 × EGR valve (Swiss specifications only)	4.8 - 7.2 (35 - 52)	—
EGR pipe No.2 × EGR valve (Swiss specifications only)	3.6 - 5.4 (26 - 39)	—
EGR pipe No.2 × Intake manifold	4.4 - 6.6 (32 - 48)	—
Fuel pipe No.2 × Delivery pipe	—	1.2 - 1.8 (9 - 13)
Fuel pipe No.2 × Sage tank	—	1.2 - 1.8 (9 - 13)
Fuel hose No.1 × Delivery pipe	—	3.5 - 4.5 (25 - 33)
Heat insulator No.2 × Exhaust manifold case No.2		1.5 - 2.2 (11 - 16)
Engine mounting rear right bracket × Cylinder block	4.5 - 6.5 (33 - 47)	4.5 - 6.5 (33 - 47)
Engine lower mounting member S/A × Cylinder block	5.0 - 7.0 (36 - 51)	5.0 - 7.0 (36 - 51)
Engine lower member S/A × Engine mounting front stopper	7.5 - 10.5 (54 - 76)	7.5 - 10.5 (54 - 76)
Engine mounting upper right insulator × Engine mounting front bracket	4.0 - 5.5 (29 - 40)	4.0 - 5.5 (29 - 40)
Engine mounting upper right insulator × Body	7.5 - 10.5 (54 - 76)	7.5 - 10.5 (54 - 76)
Engine mounting lower left bracket × Engine mounting lower left	7.5 - 10.5 (54 - 76)	7.5 - 10.5 (54 - 76)

WM-13024

